

SWIFT TRAWLER 47

OWNER'S MANUAL



BENETEAU



197885 RCD-2
Index B



CONTENTS

5	Introduction	
9	Technical specifications	1
13	Design categories and displacement	2
17	Stability and buoyancy	3
25	Manoeuvrability	4
35	Safety	5
51	Information relating to fire risks and risks of explosion	6
61	Electrical system	7
129	Liquefied Petroleum Gas (LPG) System	8
137	Domestic appliances	9
145	Audio-visual equipment	10
149	Onboard comfort	11
169	Water systems	12
193	Engine	13
211	Steering system	14
221	Deck fittings	15
235	Hull fittings	16
241	Handling, transport	17
247	Environment	18
249	Appendix	

INTRODUCTION

Welcome!

You have just been delivered your new BENETEAU boat and we thank you for the confidence you have shown in us by ordering from our brand. The whole BENETEAU team welcomes you on board.

A BENETEAU is made to last and to bring you all the pleasure you should expect from a boat over a period of many years. Each boat is subject to the utmost attention to detail from the design stage right through to launching.

This manual is designed to help you to enjoy your boat comfortably and safely. It includes the boat's specifications, the equipment provided or installed, information on the boat's systems and some tips on operation and maintenance. Some of the equipment described in this manual may be optional.

Your BENETEAU dealer will be able to help and advise you on the use and maintenance of your boat. The first time you use your boat a high level of skill and attention will be required. The proper functioning of all equipment will depend on the initial set-up being carried out correctly. For this reason the first launch must be carried out under your dealer's supervision.

Read this Owner's Manual carefully and take time to get to know your boat before you use it.

The better you know your vessel, the better your experience will be when sailing it.

Keep this manual somewhere safe and pass it on to the new owner should you sell your boat.
You are advised to keep any user's guides supplied by the manufacturers of any equipment for your boat (accessories, etc.), together with your manual.



For each piece of equipment on your boat, please read the instruction manuals provided by the manufacturer.

- This manual is written to help you enjoy your boat in safety. It contains details of the boat and of all the equipment provided and installed on your boat, as well as instructions for its use. Read it carefully and get to know your boat properly before using it.
- This owner's manual is not in any way a navigation or mariner's training manual. If this is your first boat or if you have changed to a type of boat with which you are not familiar, make sure that you learn how to use it and manoeuvre safely and with ease before taking the helm alone. Your dealer, national sailing or motorboat association, or yacht club will be very happy to tell you about navigation schools or qualified instructors in your area.
- Make sure that the wind and sea conditions forecast are appropriate for the design category of your boat and that you and your crew are capable of manoeuvring the boat in these conditions.
- Even with a well-adapted boat, the wind and sea conditions which correspond to the design categories A,B and C range from storm force winds for category A to severe storm conditions at the upper end of category C, and could put the boat at risk from very large waves and strong gusts. These are dangerous conditions in which only an experienced, fit and well-trained crew, manoeuvring a well-maintained boat, will be able to navigate with sufficient skill.
- This owner's manual is not intended as a detailed maintenance or repairs manual. Should any problems arise please contact your dealer. If a maintenance manual is provided, please use it.
- Always use the services of an experienced professional for the maintenance of your boat, for fitting accessories and for any modifications. Any alterations which may affect the safety specifications of the boat must be assessed, carried out and recorded by persons qualified to do so. The boat manufacturer cannot be held responsible for any modifications not approved by them.
- Some countries require you to hold a Certificate of Competency or other such qualifications, or there may be other specific regulations in force.
- Always maintain your boat well and make note of any deterioration due to wear and tear or to heavy or inappropriate use.
- Any boat – no matter how well-built – could suffer serious damage if used recklessly. This kind of use is highly unsafe. Always adjust the speed and heading of your boat according to the sea conditions.
- If your boat is equipped with a life-raft, read the instruction manual carefully. The crew must have all safety gear available onboard (lifejackets, harnesses etc.), and this must appropriate for the type of boat and for the weather conditions. In some countries it is mandatory to have this safety equipment onboard. The crew must be fully familiarised with the use of the safety gear and with emergency manoeuvres (man overboard procedures, towing another vessel etc). Sailing schools and clubs regularly run training sessions for these skills.
- It is strongly advised that everyone wears an appropriate flotation device (lifejacket or personal buoyancy aid) when on deck. Be advised that in some countries it is mandatory to wear a flotation device which meets the national regulations at all times.

Notes on reading this manual

The various symbols used throughout the manual for crucial safety information are as follows:



DANGER

Indicates a serious inherent danger with a high risk of death or serious injury if the appropriate precautions are not taken.



WARNING

Indicates a danger which could lead to injury or death if the appropriate precautions are not taken.



WARNING

Either indicates a reminder of safety procedures or alerts you to dangerous manoeuvres or operations, which could result in injuries to those onboard, damage to the boat and its components or damage to the environment.



ADVICE-RECOMMENDATION

Indicates recommendations or advice for carrying out the correct manoeuvres for the planned course of action.

- While some of the information and illustrations in this manual may show details which are slightly different from those found on your boat, the key information remains the same. Future versions of this manual will show any possible modifications as required.
- Due to the constant desire to improve the products, SPBI S.A. reserves the right to make any changes considered necessary to the design or to the equipment. The specifications and information given are not contractual and may be modified without prior notice or updates.



- This owner's manual is written in several languages. French is the authentic reference language.
- This owner's manual was written and formatted by SPBI S.A.. Any reproduction of this manual, direct or indirect, provisional or permanent, by whatever means, whether in whole or in part, as well as any modification by third parties for commercial reasons, is forbidden.

TECHNICAL SPECIFICATIONS

■ Construction	10
■ General dimensions	10
■ Engine.....	10
■ Electricity	10
■ Capacities.....	11

1.1 CONSTRUCTION

Model.....	SWIFT TRAWLER 47
Architect / Design	MICAD / Andreani Design
Builder	SPBI S.A
Principal means of propulsion	Motor
Hull and deck construction material	Laminated sandwich glass / GRP / Balsa wood & Sinter
Application	Infusion

1.2 GENERAL DIMENSIONS

L.O.A (L_{max})*	14,74m
<i>(Including removable parts that can be dismantled (bow roller, pulpit, bowsprit), without affecting the structure of the boat)</i>	
Hull length (L_h)*	12,77m
<i>(Excluding: removable parts that can be dismantled without affecting the structure of the boat)</i>	
Overall width (B_{max})*	4,50m
<i>(Including: removable parts that can be dismantled without affecting the structure of the boat)</i>	
Beam(B_h)*	4,42m
<i>(Excluding: removable parts that can be dismantled without affecting the structure of the boat)</i>	
Air draft - Empty vessel:	5,79m
Draught - Boat fully laden:	1,20m
Wetted surface area	Approximately 52 m ²

1.3 ENGINE

Nominal maximum propulsion power (at the propeller shaft line)	2 x 328Kw
Maximum recommended engine size.....	2 x 692kg

1.4 ELECTRICITY

Circuit type: Direct current DC.....	12V
Alternating current AC	220V
AC (US Version).....	110V

1.5 CAPACITIES

Total mass of liquid contents of fixed tanks when full 2 843kg

NOTE: The density of a liquid can vary according to its temperature and quality.

The volume masses chosen are:

- 0,86kg/L for diesel fuel,
- 1kg/L for water.

Fuel capacity: Tank 1 (*)	970L
Tank 2 (*)	970L
Fresh water capacity: Tank 1 (*)	320L
Tank 2 (*)	320L
Blackwater capacity (Toilet):	170L
Waste water capacity (Washbasin, Shower, Domestic appliances): Collector	45L
Tank.....	320L

It may not be possible to use these capacities fully depending on the trim and load of the boat. It is recommended that you keep a reserve of 20% in the fuel tanks.

()*: Refer to the corresponding chapter to locate the position of the tank (each tank number corresponds to its position on board).

DESIGN CATEGORIES AND DISPLACEMENT

■ Design categories..... 16

- Some information is shown on the manufacturer's plate fixed to the boat. Explanations of the information given can be found in the relevant chapters of this manual.

Design category	B	C	D
Maximum number of people onboard (CL)*	12	14	14
Maximum number of people to be allowed on the flybridge	4	14	14
Light displacement (MLC)**	12 717kg		
Recommended maximum load (ML)***	6 730kg		
Displacement with maximum load (MLDC)****	19 447kg		

NOTE: The options fitted onboard are included in the maximum load. The more options the boat has, the less room there is for provisions or personal belongings.

DEFINITION:

* **CL:** Crew Limit

** **MLC:** Mass of the boat in Light Craft Condition

includes the weight of the boat in the standard ready-to-navigate configuration, keel, standard equipment, engine(s) and sails (if the boat is a sailing boat).

*** **ML:** Maximum Load

- The recommended maximum load includes the weight of all people onboard, provisions, personal belongings, all equipment not included in the weight of the boat when not loaded, the cargo (if relevant) and all liquids contained in fixed tanks when full (fuel, water, greywater, blackwater).

- The maximum recommended weight shown on the manufacturer's plate does not include the weight contained in the fixed tanks of liquid when full (fuel, water, greywater, blackwater).

**** **MLDC:** Mass of the boat in Maximum Load Condition

Includes light ship mass (MLC) + maximum load (ML).

- If some of those onboard are children, the total number of people allowed onboard may be increased, provided that:
 - The total weight of the children does not exceed 37,5kg;and that
 - the total weight of all allowed onboard (based on about 75kg per adult) is not exceeded.

 - Do not exceed the recommended maximum number of people onboard. However many people are onboard, the total, combined load of people and any gear or equipment must never exceed the recommended maximum load.

- Always use the seats or seating areas provided.

 - When loading the boat, never exceed the recommended maximum load. Always load the boat with care and distribute weight evenly in order to maintain the optimum trim (more or less horizontal).

- Avoid placing heavy loads high up in the boat.

2.1 DESIGN CATEGORIES

Category A:

A yacht of design category A is considered to be designed for wind that may exceed force 8 (on the Beaufort scale) and waves that can exceed a significant height of 4 metres, but excluding exceptional conditions such as storms, severe storms, tornadoes and extreme sea conditions or very large waves.

Category B:

A yacht of design category B is considered to be designed for wind that may go up to force 8 inclusive and waves that can reach a significant height up to 4 metres inclusive.

Category C:

A yacht of design category C is considered to be designed for wind that may go up to force 6 inclusive and waves that can reach a significant height up to 2 metres inclusive.

Category D:

A yacht of design category D is considered to be designed for wind that may go up to force 4 inclusive and waves that can reach a significant height up to 0,3 metres inclusive, with occasional waves of a maximum height of 0,5 metres.

NOTE: Boats in each category must be designed and built to withstand these parameters in respect of stability, buoyancy and other relevant essential requirements, and to have good handling characteristics.

STABILITY AND BUOYANCY

- Stability information..... 18
- Access to the boat..... 19

3.1 STABILITY INFORMATION

- Fully laden displacement was used to evaluate the stability and buoyancy of the boat. The value of this displacement can be found in the "Technical specifications" paragraph at the beginning of this manual.
 - Any changes in the distribution of loads onboard (for example by adding a raised structure for fishing, fitting a radar or in-mast furling, changing the engine etc.) can significantly affect the boat's stability, trim and performance;
 - It is important to keep water in the bilges to a minimum;
 - Adding weight high up on the boat will affect stability;
 - In heavy weather it is important to close all the hatches, lockers and doors to minimise the risk of water pouring in;
 - The boat's stability can be reduced when towing a boat or when using a davit or boom to lift a heavy load;
 - Breaking waves are a serious threat to stability.
- It is important to take additional precautions in the event of strong winds, rough seas or breaking waves.
- Do not install an engine in this boat with a higher power rating than indicated on the manufacturer's plate of the boat.
 - Do not drive the boat at high speed with a negative trim of the propulsion equipment (bow down). This can make the boat heel and cause it to be unstable when turning.
- Use a negative trim to make the transition from displacement speed to planing speed, and at lower speeds in choppy seas (applicable to boats equipped with a system for directing the propeller thrust).
- Do not drive at top speed in areas of heavy boat traffic or in situations of reduced visibility, strong winds or heavy seas. Reduce the boat's speed and wake out of courtesy and for your own safety and the safety of others. Observe speed limits and "NO WASH" signs.
 - Observe right of way as defined by the rules of marine traffic and required by international regulations to prevent collisions at sea (RIPAM / Col Reg).
 - Ensure that you always have sufficient room to stop or manoeuvre if necessary in order to avoid a collision.
 - Avoid abrupt manoeuvres at full speed.
 - Do not sit on the forward section of the cockpit when the boat is moving at high speed.
 - Reduce speed in large waves for your comfort and safety.



- Reduce speed in wavy conditions.
- Always adjust the speed and heading of your boat according to the sea conditions.
- All of the watertight hatches must remain closed when at sea.
- If the wind exceeds 20 knots, it is recommended that you stow all removable protection sheets (Bimini, awnings, ...).

3.2 ACCESS TO THE BOAT

Access to the cockpit



Gangway access



- It is essential that both the cockpit and the engine compartment are kept closed when at sea.
- When at sea close the guardrail side-opening or openings.
- Slamming an access hatch may cause injury : always close the hatch gently and carefully.
- Do not allow children to open or close the hatches unsupervised.



- It is essential that the access doors to the saloon are kept closed when at sea.
- Close the deck hatches and portholes before each trip.
- Close all access doors and hatches in heavy weather or when the sea is rough.



- When under way, keep hull valves and fillers in the closed position to minimise the risk of flooding.

Access to the engine compartment

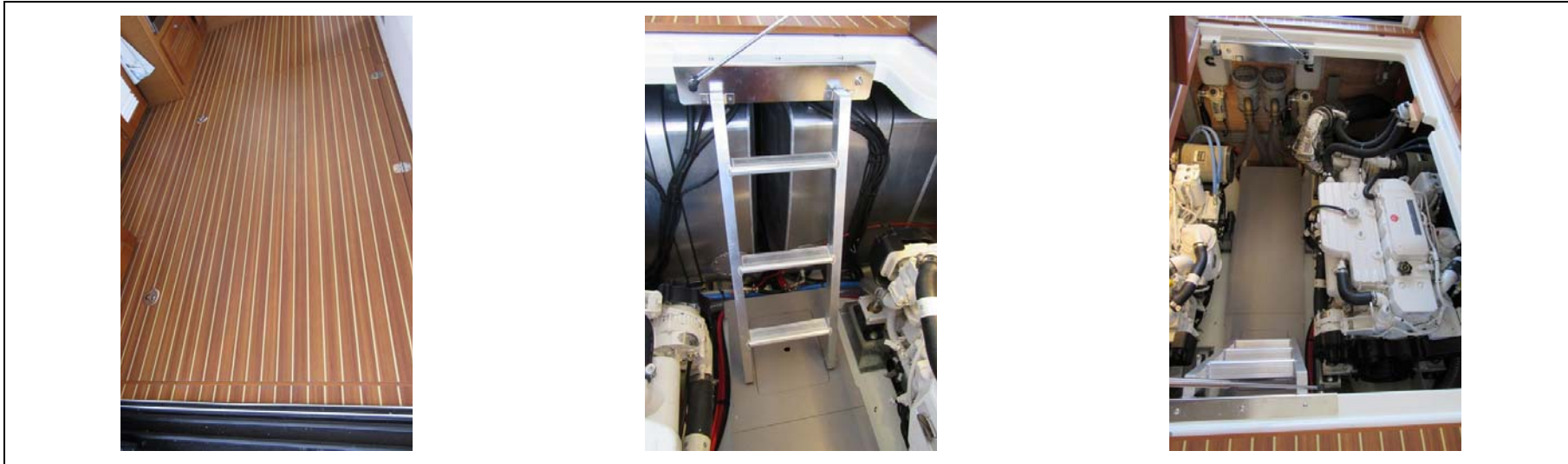

Access to the cockpit locker



Flying bridge access



NOTE: To avoid the risk of falling, it is recommended that you close off access to the flying bridge immediately after climbing up.

Access to the starboard passageway

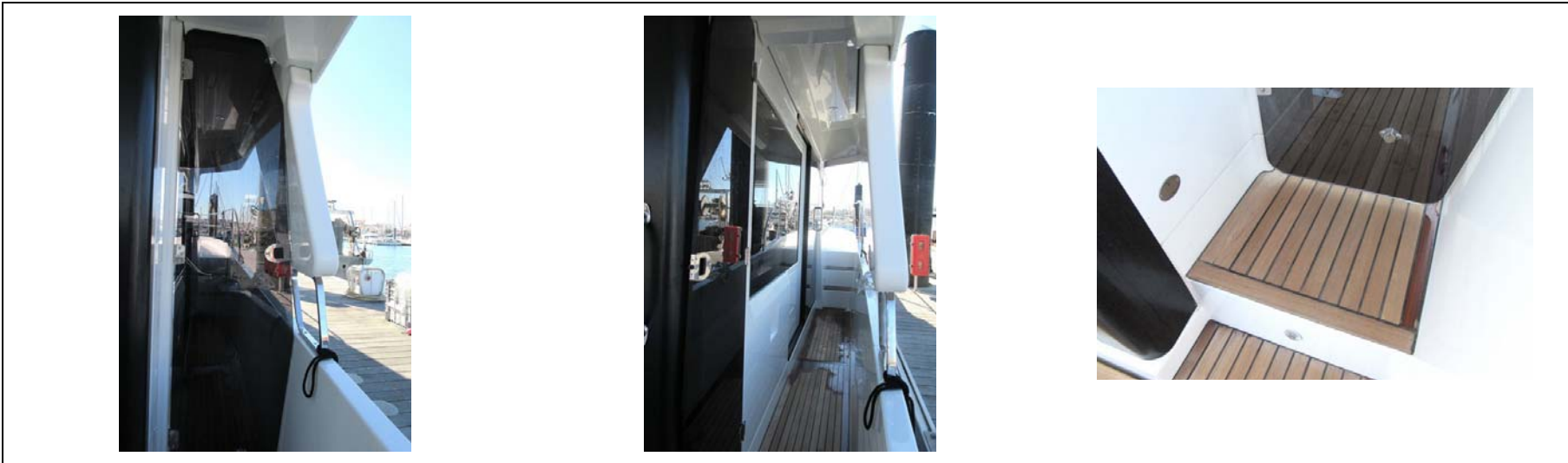

Access to the saloon

Aft window door



Side bay window



When sailing, the bay window can be open or half-open. However, it must be kept in the locked position by the two locks (top and bottom) to avoid sudden closing.

Foredeck access

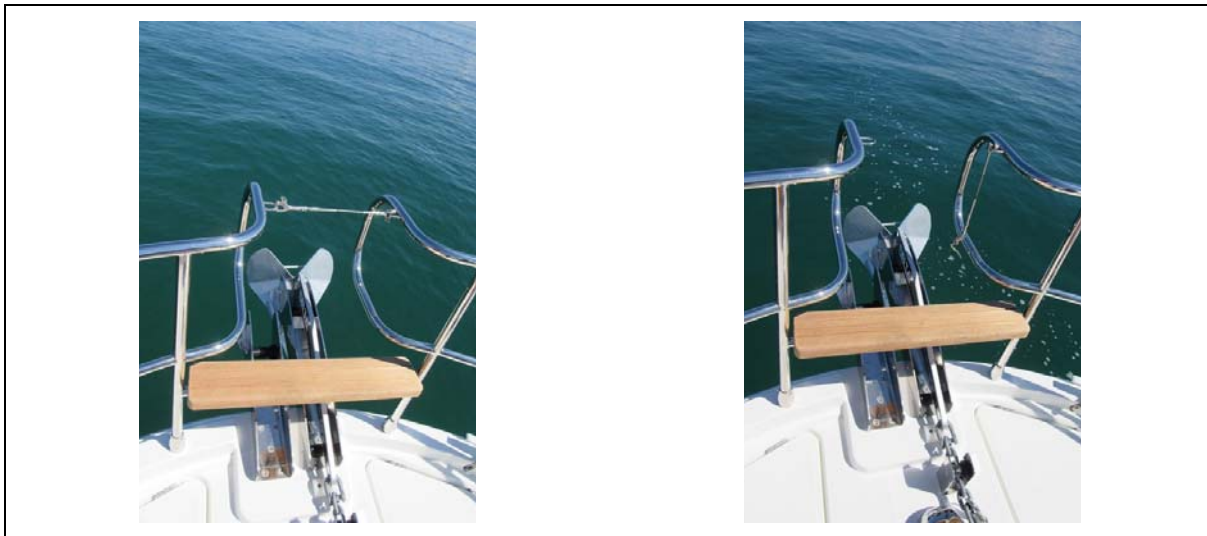

NOTE: *It is essential that the guardrail is closed when sailing.*

MANOEUVRABILITY

■ Visibility from the steering station..... 26

4.1 VISIBILITY FROM THE STEERING STATION

The view of the helmsman from the helm station can be obstructed by the boat heeling significantly or because of other factors caused by one or several of the following variable conditions:

- 1) Adjustment angle of the propulsion system (trim) (On boats equipped with an engine push angle regulator);
- 2) Angles of level control flaps (On boats fitted with level control flaps, powered or fixed, installed on the transom);
- 3) Load and load distribution;
- 4) Speed;
- 5) Rapid acceleration;
- 6) Transition from displacement mode to planing mode;
- 7) Sea conditions;
- 8) Rain and mist;
- 9) Darkness and fog;
- 10) Lights inside the boat;
- 11) Position of covers and curtains;
- 12) Persons or mobile equipment located in the helmsman's field of view.

The international rules and regulations for avoiding collisions at sea (Col Reg / RIPAM) require a full and constant lookout as well as observance of the rules of right-of-way. Observance of these rules is essential.



- Manoeuvrability is reduced at excessive speeds.
 - There is a risk of loss of control during tight turns.
 - Reduce speed before making a turn in any direction.
- The visibility of the inside helm station is reduced on the stern of the boat: Please keep the necessary watch.

Two helm stations are fitted on the boat:

- the main helm station in the saloon,
- the secondary helm station on the flying bridge.

Depending on the version chosen, an additional joystick can be fitted in the cockpit.

NOTE: Some functions or commands are only accessible from the main helm station.

Pilot footrest adjustment



4.1.1 Demister

- The demister runs on DC power.
- The demister uses heat recovered from the boat's engine to demist the windscreen. It operates on the port engine cooling circuit exchanger.
- The demister operates only when the engine is warm and running.
- A valve on the engine allows the demister to be isolated from the engine cooling system (for maintenance or to isolate a faulty circuit).

Control: Steering station

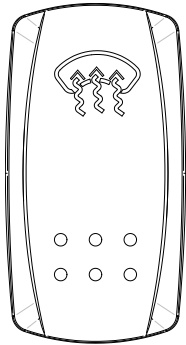

Location:



Hot air outlet (on the windscreen)



Port engine/demister cooling system supply valve



4.1.2 Wiper

The windscreen wipers run on DC power.

Control: Steering station

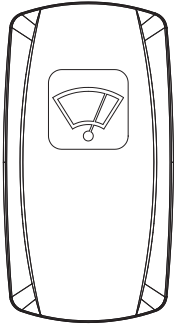

Location:



Engine access: Deckhead (Wheelhouse)

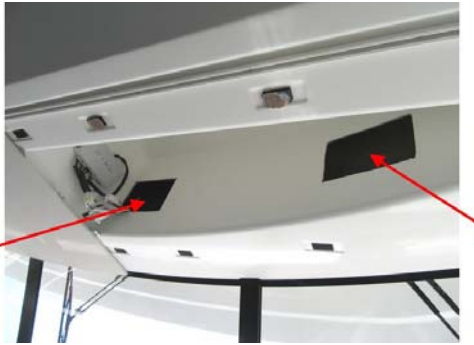

4.1.3 Windscreen washer

Control: Steering station

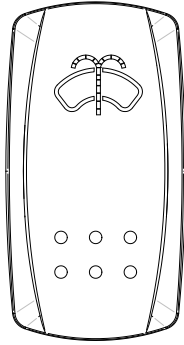

Reservoir location:
Flying bridge (Under the starboard bench
seat)



4.1.4 Horn

The foghorn runs on DC power.

The horn can also be controlled from Ship Control (see Chapter: SHIP CONTROL).

Control: Steering station

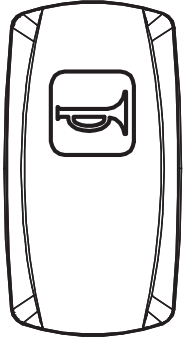

Location:



Compressor
Location: Flying bridge (Under the starboard bench seat)



4.1.5 Deck searchlight

- The deck searchlight runs on DC power.
- A fuse protects the electrical circuit.

 Refer to the manufacturer's instructions for use and maintenance.

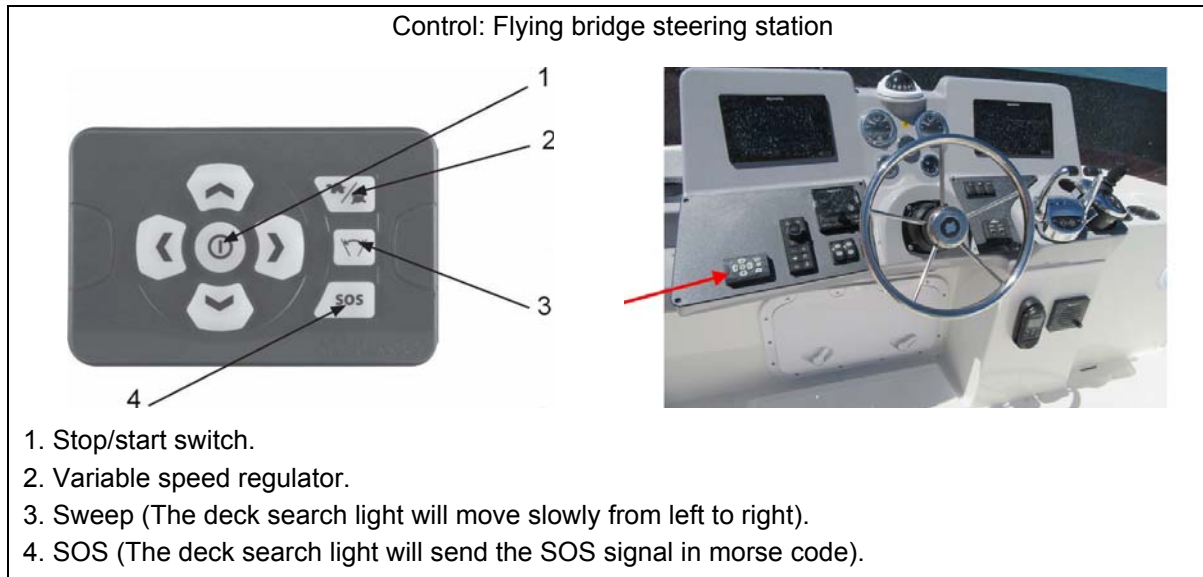

4.1.6 Navigation lights

The navigation lights run on DC power.

The navigation lights can also be controlled from Ship Control (see Chapter: SHIP CONTROL).

Control: Steering station

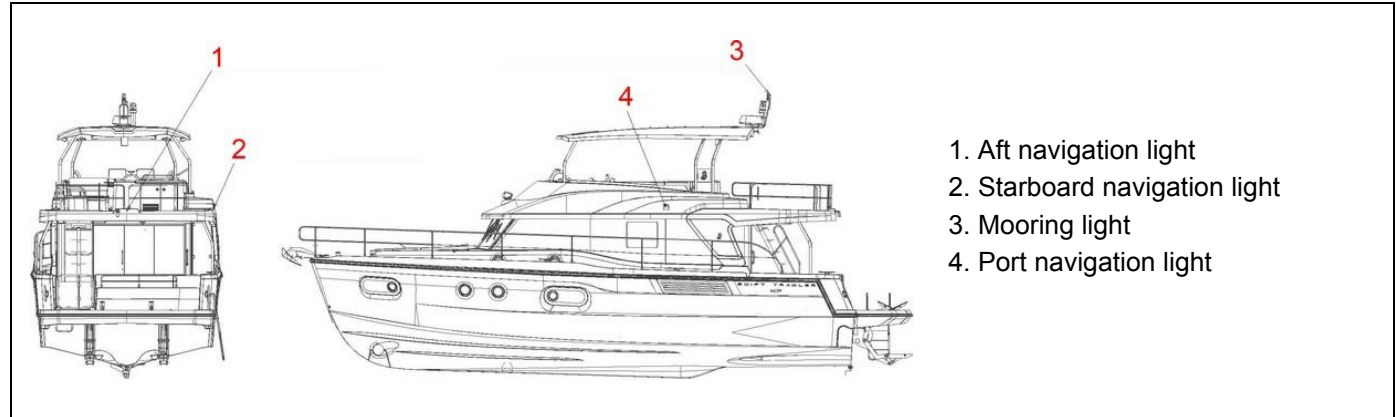
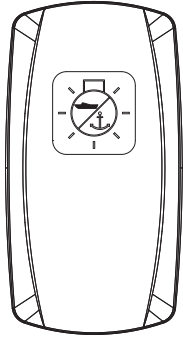

1. Aft navigation light
2. Starboard navigation light
3. Mooring light
4. Port navigation light

Aft navigation light



Starboard navigation light



Mooring light



NOTE: The only function of the samson post is to support the navigation light. Any other use is dangerous and must be strictly avoided.

SAFETY

- Preventing man overboard situations and means of reboarding .. 36
- Storing the liferaft..... 39
- Securing moveable items 40
- Information on flooding risks and boat stability 41
- Emergency systems in case of steering gear failure..... 49
- Information on lightning-related risks..... 50

5.1 PREVENTING MAN OVERBOARD SITUATIONS AND MEANS OF REBOARDING

5.1.1 Prevention of man overboard

- The off-limits areas of the working deck when under way are cross-hatched below



- "Working deck" refers to the exterior parts of the boat where people stand or walk during normal use.

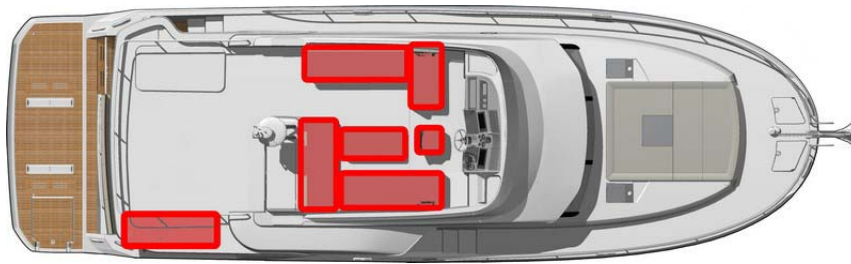

Use the seats provided.

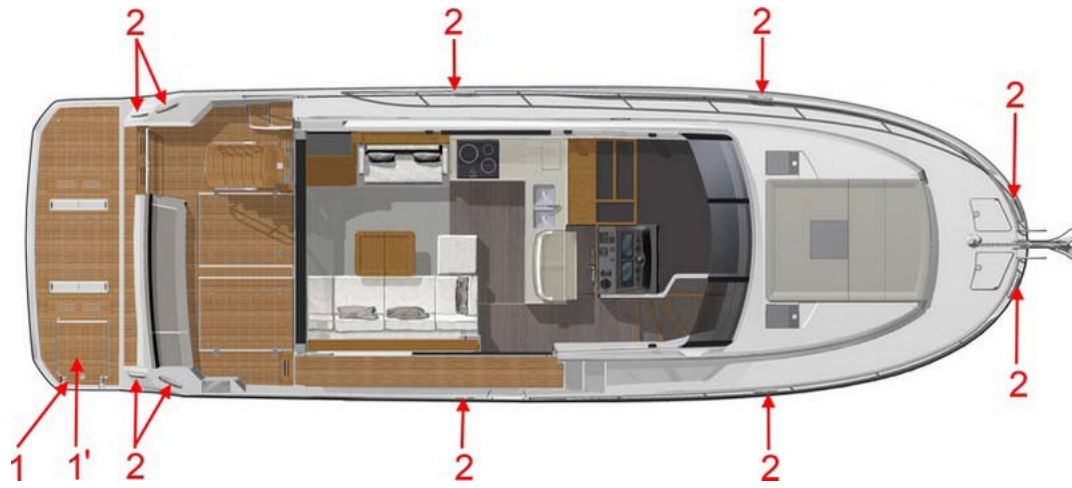

Ref 1 & 1': Reboarding device.

Ref 2: Mooring cleats (corresponding to the anchor points for the lifelines).

Regularly check the guardrails:

- With metal guardrails look out for signs of corrosion (particularly at connecting points).

Regularly check the tension of the lifelines and the attachment points.

5.1.2 Reboarding

A reboarding device must be usable from the water by a single person with no external help.

Configuration of reboarding device:
Swimming ladder (Ref 1')



- Some types of reboarding equipment have a locking device when folded up: It is important to keep the means for getting back onboard deployed and ready to use once the boat is in use (at anchor, moored or at sea).
- Make sure that means for getting back onboard are readily accessible and easy to use by someone alone in the water.

Configuration of reboarding device in the event of an accidental fall:
(Ref 1)



5.2 STORING THE LIFERAFT

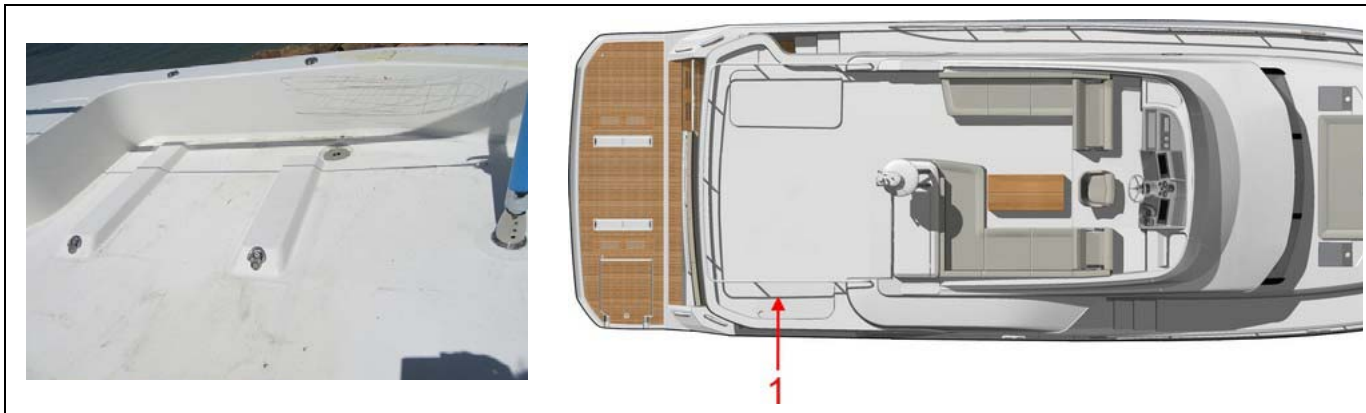

The liferaft (not supplied) must be stored in the space provided for it (Ref 1). A pictogram allows for easy location.



- ⚠ - Before putting to sea, carefully read the launching instructions shown on the liferaft.
- It is the responsibility of the skipper to ensure regularly that the liferaft is properly secured in place.

5.3 SECURING MOVEABLE ITEMS

The technical areas are identified in the boat by the pictogram below:



The electrical technical areas are identified in the boat by the pictogram below:



Technical areas may not be used as storage compartments.



- Ensure that movable items are firmly secured when sailing.
- Do not store anything below the floorboards.

5.4 INFORMATION ON FLOODING RISKS AND BOAT STABILITY

5.4.1 Hull openings

Valves, thru-hull inlets and other brass or bronze fittings have a lifespan of around 5 years. All valves, thru-hull inlets and other brass or bronze accessories must be checked by a professional every year and replaced as necessary.

AFT HULL VIEW

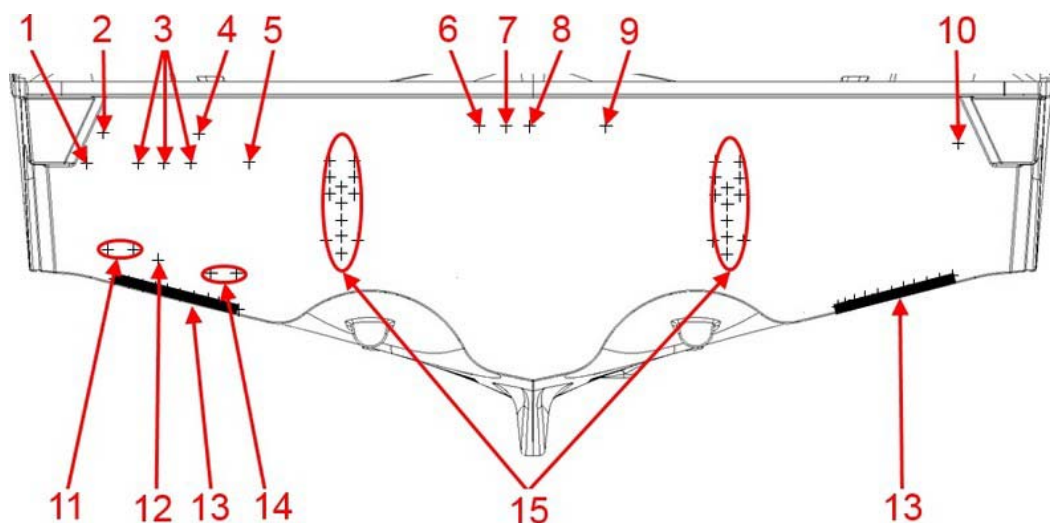

Reference	Designation	Valve
1	Condensation water drainage - Air conditioning	Yes
2	Flying bridge draining	No
3	Air conditioning drainage	Yes
4	Foot bath drain	No
5	Air conditioning drainage	Yes
6	Drainage of aft electric bilge pump	No
7	Drainage of manual bilge pump	No
8	Forward electrical bilge pump draining	No
9	Gas locker outlet	No
10	Flying bridge draining	No
11	Generator earthing plate	No
12	General anode	No
13	Flaps	No
14	Inverter earthing plate	No
15	Tenderlift support	No

HULL TOP VIEW

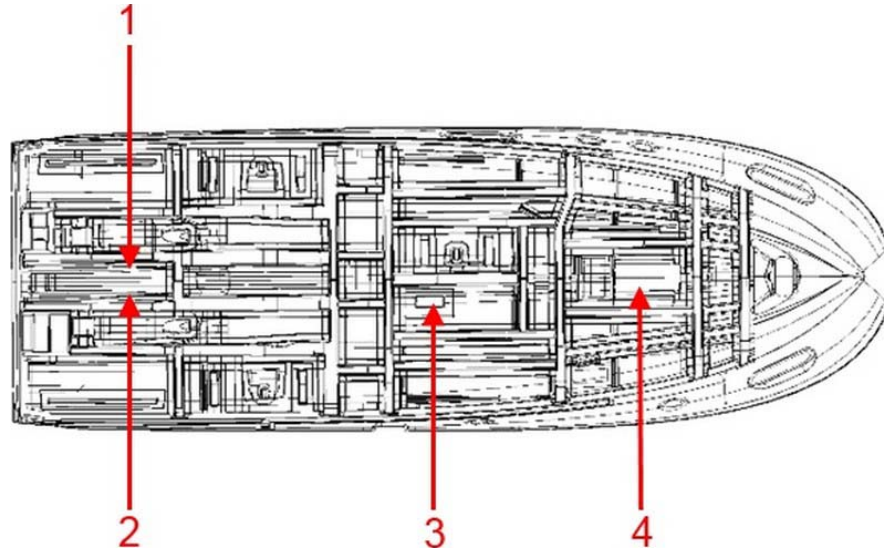

Reference	Designation	Valve
1	Port engine seawater intake	Yes
2	Starboard engine seawater intake	Yes
3	Electronic sensor	No
4	Blackwater drainage tank	Yes

VIEW OF HULL, STARBOARD SIDE

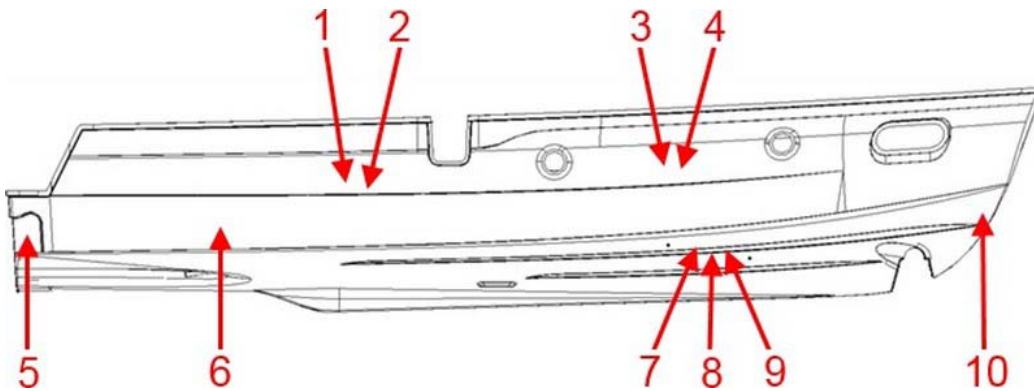

Reference	Designation	Valve
1	Fuel tank vent	No
2	Side deck evacuation	No
3	Blackwater tank vent	No
4	Waste water tank vent	No
5	Port engine exhaust	No
6	Cockpit draining	No
7	Greywater manifold drainage	Yes
8	WC seawater intake	Yes
9	WC seawater intake	Yes
10	Chain locker scupper	No

VIEW OF HULL, PORT SIDE

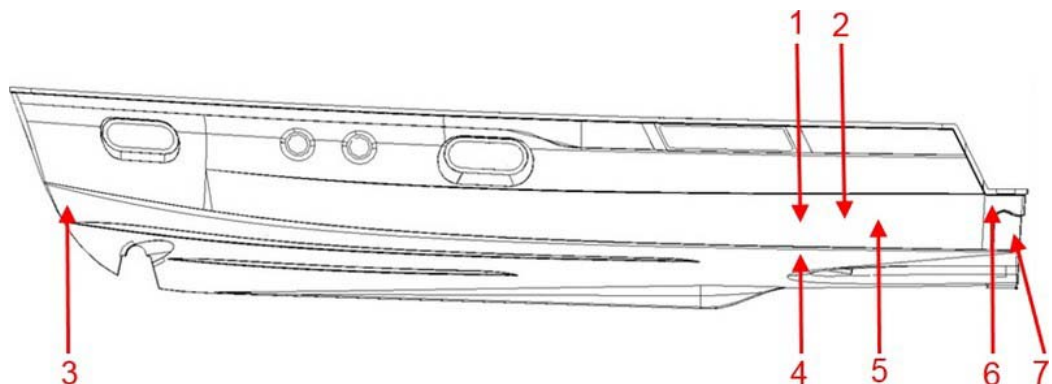

Reference	Designation	Valve
1	Generator drain	Yes
2	Galley sink drainage	Yes
3	Chain locker scupper	No
4	Generator seawater intake	Yes
5	Cockpit draining	No
6	Generator exhaust	No
7	Port engine exhaust	No

5.4.2 Drainage system

General points

- The inner moulding of the hull is equipped with channels: these are the drainage channels. The drainage channels allow the water to drain down to the lowest point in the boat, where it can be discharged. It is important to allow the water to flow freely down to this lowest point of the boat, which means.
- regularly cleaning the lowest point of the boat and the drainage channels.

DIAGRAM OF LAYOUT - DRAINAGE CHANNELS

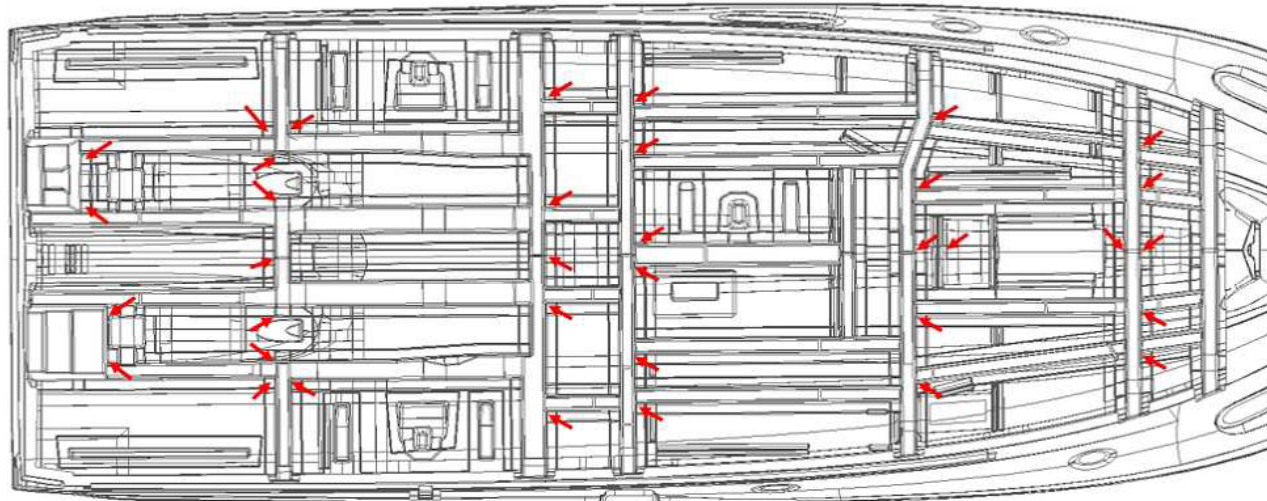
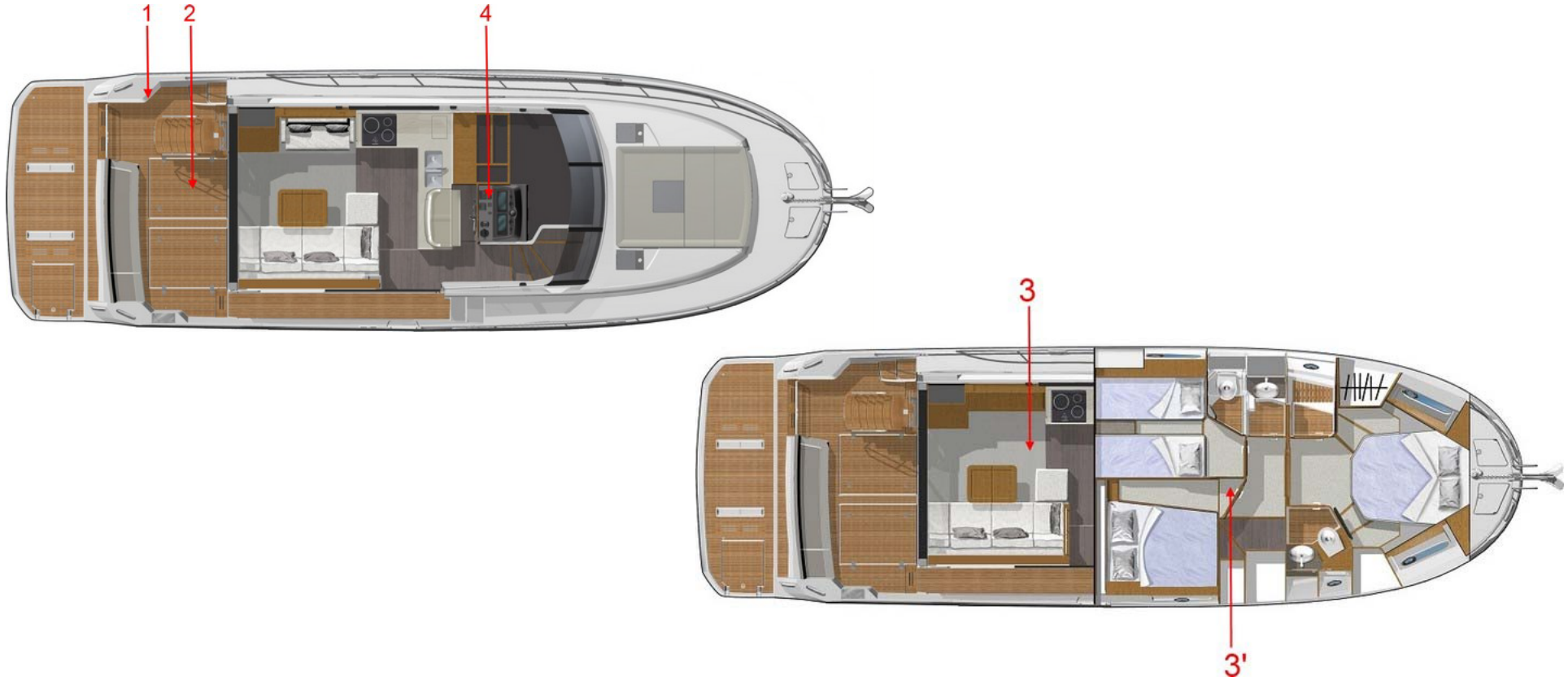

DIAGRAM OF LAYOUT - BILGE PUMPS



Reference	Designation	Rate
1	Manual bilge pump	32L/minute (*)
2	Manual bilge pump lever	
3 & 3'	Electric bilge pump	69L/minute
4	Electric bilge pump switch	

(*) 45 strokes/minute

Secondary drainage system **Manual bilge pump**

The manual bilge pump is in the cockpit (Ref 1).

The bilge pump lever is located nearby (Ref 2).

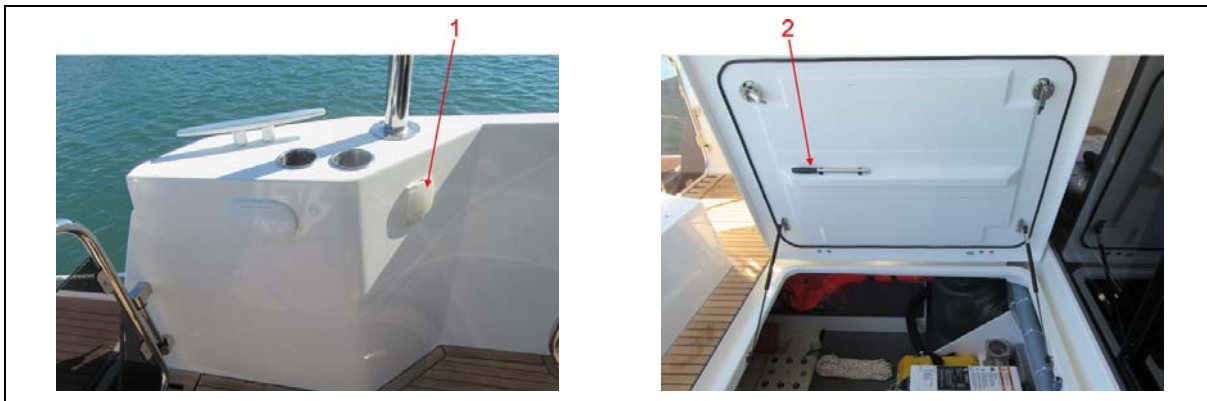

Operation:

I- Attach the lever to the manual bilge pump.

II- Repeatedly work the lever up and down to its fullest extent.

The manual bilge pump lever must remain accessible at all times.



Main drainage system Electric bilge pumps

- The bilge pumps are powered by DC.

Location of the electric bilge pumps:

Ref 3: Engine compartment

Ref 3': Starboard aft cabin

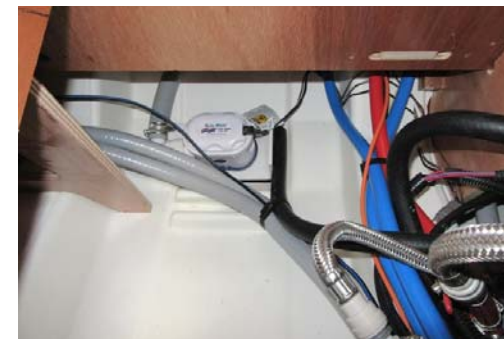
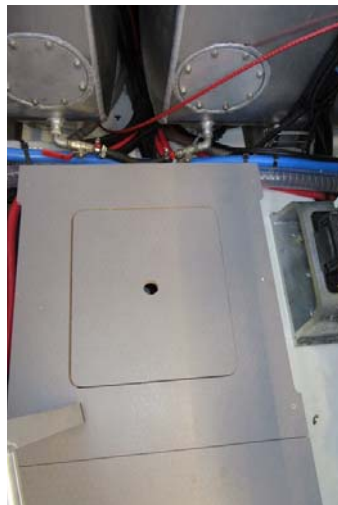

- The electric bilge pump switch is located at the helm station (Ref 4).
- The bilge pumps can also be controlled from Ship Control (see Chapter: SHIP CONTROL).

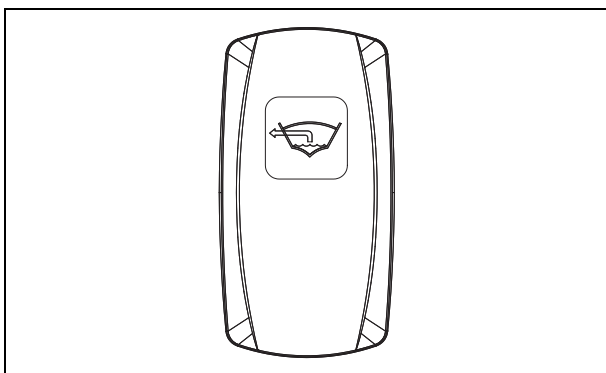

- The electric bilge pump must only be used to discharge stagnant water at the bottom of the bilge. It must not be used to pump out any oil-based products (petrol, oil) or inflammable liquids.

Operation:

I- Turn on the battery switches.

II- Switch on the bilge pump (Ref 4).

If the boat is equipped with an automatic bilge pump, the switch has an always-on position.

Bilge pump maintenance

Please refer to the manufacturer's notes in the instructions for checking and maintaining the bilge pumps.



- The drainage system is not designed to control water coming from breaches in the hull.
- Keep the water level in the bilges to a minimum.
- Never store anything at the very bottom of the boat: Allow bilge water to flow freely down to the lowest point of the boat.



- Check that each bilge pump is working at regular intervals.
- Remove debris that could clog the bilge pump suction strainers.

DIAGRAM OF LAYOUT - DRYING OUT THE BILGE

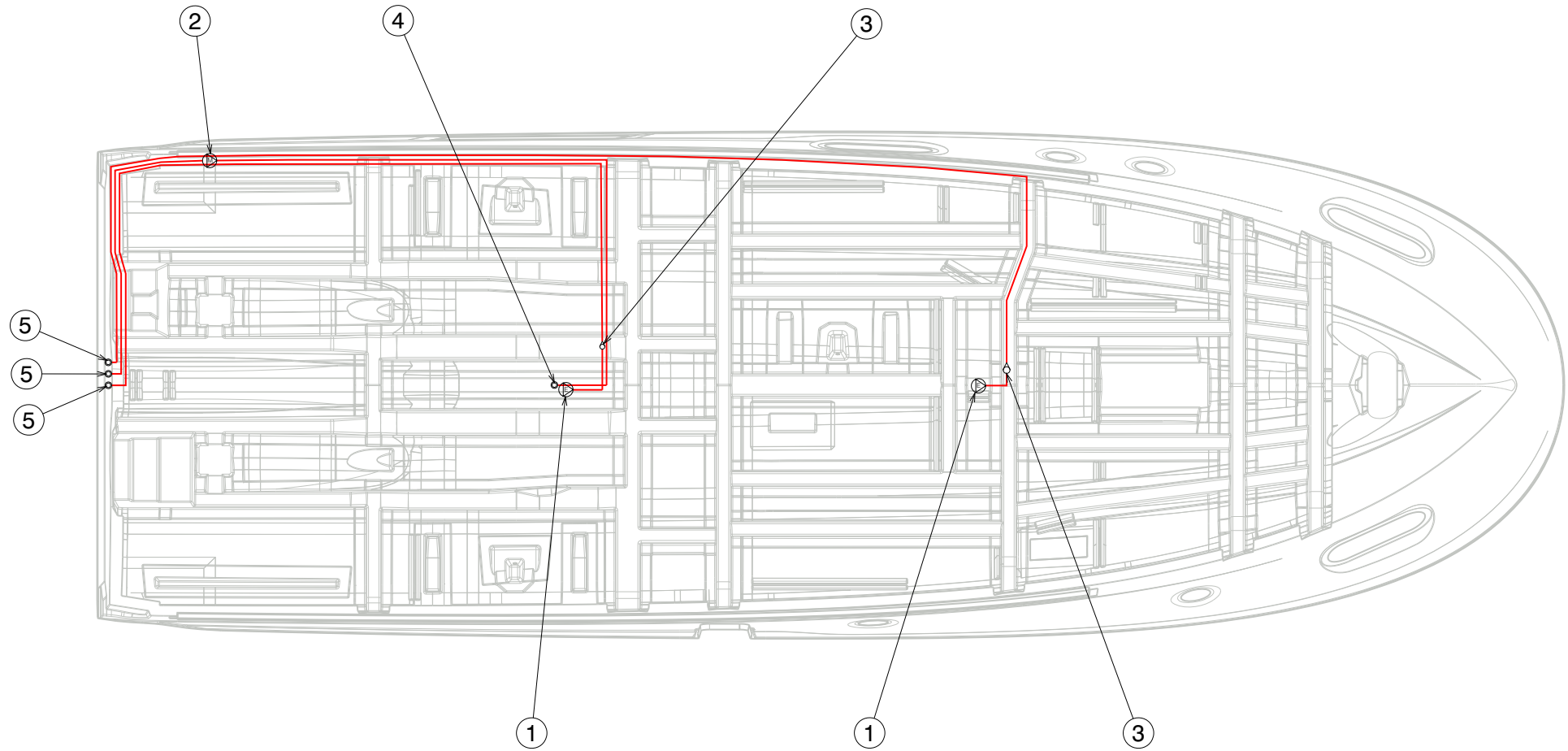

Reference	Designation
1	Electric bilge pump
2	Manual bilge pump
3	Non-return valve
4	Intake filter
5	Kitchen sink thru-hull drainage

5.5 EMERGENCY SYSTEMS IN CASE OF STEERING GEAR FAILURE

INSTRUCTIONS IN THE EVENT OF STEERING GEAR FAILURE

On a twin engine, steering is enabled by the difference in propulsion between the port and starboard motors (difference in power and/or forward/aft).

Emergency steering using the engine control lever

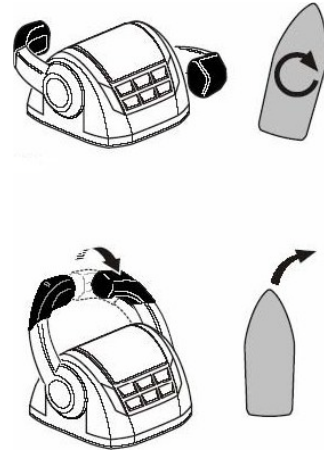

 - Refer to the manufacturer's instructions for detailed use of the system.

5.6 INFORMATION ON LIGHTNING-RELATED RISKS

- The skipper must check the weather conditions before deciding to put to sea. If there is a risk of thunderstorms, the skipper must avoid putting to sea.

Precautions to be taken by the occupants of the boat during a storm

- Ensuring the safety of everyone on board is the fundamental goal of lightning protection.
- Turn off the engine, turn off the battery switches and disconnect all electronic and electrical equipment.
- Occupants should stay as much as possible inside the closed vessel.
- Occupants should not be in the water or let their arms or legs hang in the water.

Maintenance

- Flexible radio antennas should not be tied down during a thunderstorm.
- If the boat has been struck by lightning, the compass and electronic and electrical equipment must be examined to determine whether any damage or calibration change has occurred.

INFORMATION RELATING TO FIRE RISKS AND RISKS OF EXPLOSION

■ Propulsion engines and other fuel-burning equipment	52
■ Electrical system	52
■ Gas system	52
■ Fire fighting and prevention equipment.....	53
■ Emergency exits in case of fire.....	60

6.1 PROPULSION ENGINES AND OTHER FUEL-BURNING EQUIPMENT

 The risks associated with motorisation are described in the **ENGINE** chapter.

Note concerning the boat's tender:

- If the tender is fitted with a more powerful outboard motor than 25kW, it must have on board a portable extinguisher with a rating equal to or greater than 8A / 68B.
- Place for storage of tender petrol tank: on deck.

 The risks associated with other fuel-burning equipment are described in the **FUEL-BURNING EQUIPMENT OTHER THAN FOR PROPULSION** chapter.

6.2 ELECTRICAL SYSTEM

 The risks associated with the electrical systems are described in the **ELECTRICITY** chapter.

6.3 GAS SYSTEM

 The risks associated with the gas system are described in the **GAS** chapter.

6.4 FIRE FIGHTING AND PREVENTION EQUIPMENT

6.4.1 Fire-fighting equipment

Portable fire-extinguishers and fire blanket (not supplied)

- When in use, this boat must be equipped with portable fire extinguishers of the following extinguishing capacities, located in the following places:

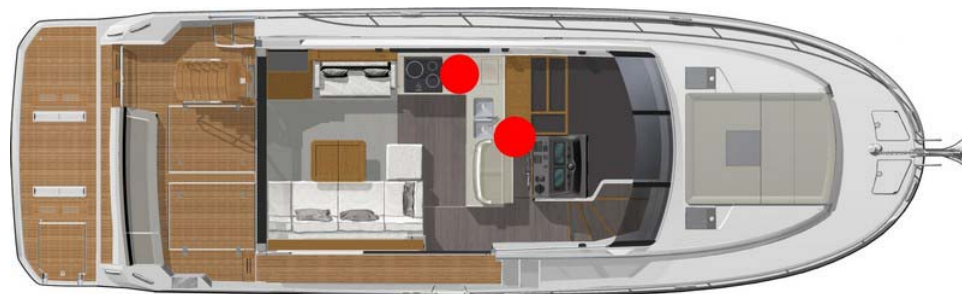

Location :	Minimum extinguishing capacity:
- Galley	5A / 34B
- Forward cabin closet	5A / 34B
- Tilling position	5A / 34B

- The location of the portable fire extinguishers is shown by the pictogram below:



- When in use, this boat must be equipped with a fire blanket to protect the cooking equipment and/or the galley, installed in the following place: near the cooking equipment.

Maintenance of the fire-fighting equipment

The owner/person operating the boat must:

- Have fire-fighting equipment checked as frequently as recommended by the manufacturer;
- Replace portable fire extinguishers, if outdated or discharged, with extinguishing apparatus of equal capacity;
- Provide at least one fire bucket with a lanyard, in a readily accessible place, for protection of the deck;
- Have fixed fire extinguishing systems filled or replaced if they have been discharged or have expired.

Responsibility of the owner/boat operator

It is the responsibility of the owner/boat operator to:

- Ensure that the fire-fighting equipment (portable extinguishers, bucket and fire blanket) is readily accessible when there are people onboard;
- Ensure that the engine compartment fire extinguisher discharge port is readily accessible;
- Show the members of the crew:
 - The location and use of the fire-fighting equipment;
 - The location of evacuation routes and fire exits.
- Unlock all deck hatches and fire escape openings when the vessel is occupied.



NEVER:

- Obstruct the passages leading to the emergency exits and the hatches;
- Obstruct or block safety controls, for instance fuel shut-off valves, gas taps, electrical system circuit-breakers;
- Obstruct the access to the portable extinguishers stored in lockers;
- Leave the boat unsupervised when cooking equipment and/or heating equipment is in use;
- Modify any of the boat's installations (especially the electrical, fuel or gas installations) or allow unqualified personnel to proceed with modifying these installations;
- Fill the fuel tanks or replace gas bottles while the engine is running or while cooking or heating equipment is in use;
- Use gas lamps in the boat;
- Smoke when handling fuel or gas;
- Obstruct the ventilation of the compartments or spaces, in particular those containing the engines, tanks or batteries.

Notes for the attention of the boat user

General points

- Check that the bilges are clean and frequently check that there are no fuel/gas vapours or fuel leaks.
- When replacing components of the fire-fighting equipment, use only appropriate components of the same code designation or with the equivalent technical capacity and fire resistance.
- Do not install free-hanging curtains or other fabrics near or above the cooking appliances or other equipment with a naked flame.
- Do not store combustible materials in the engine compartment. If non-combustible materials are stored in the engine compartment they must be secured so there is no danger of them falling on machinery and they do not obstruct access to and from the compartment.
- The fire exits other than the door or main companionway are identified by the following symbol:



6.4.2 Fixed extinguishing system with manual control

- This boat is fitted with a fixed fire extinguishing system to protect the engine compartment.
- Procedure to follow in the event of fire in the engine compartment:
 - Stop the engine and fan,
 - Disconnect electrical power (turn off all battery switches) and fuel supply,
 - Close access to the compartment,
 - Activate the extinguisher control for 20 seconds,
 - Wait,
 - Ventilate the compartment after the fire has been extinguished,
 - Open the access hatches and repair.

NOTE: Turning off the engine is not enough to turn off the fan. The starter key must be turned OFF to disconnect the power supply to the engine circuit.



To enable functioning of the fixed fire extinguishers, the safety pins on each extinguisher must all be removed completely.



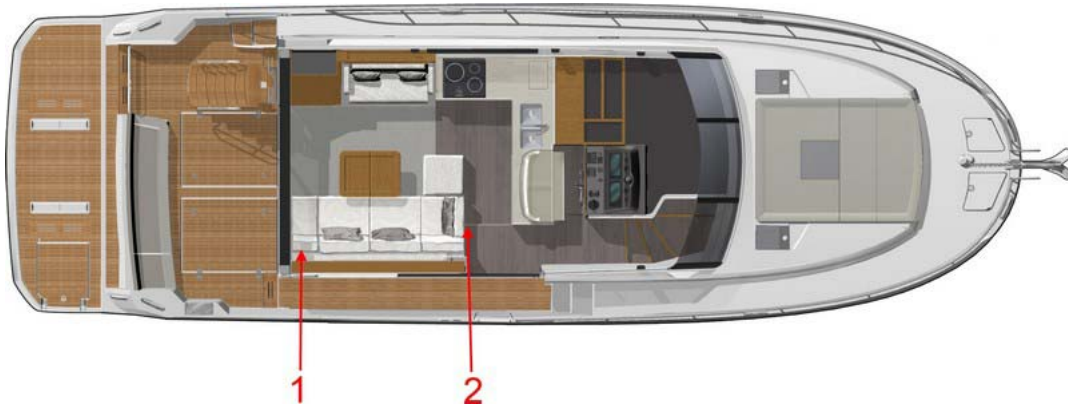

Ref 1: Fixed extinguisher
Location: Engine compartment

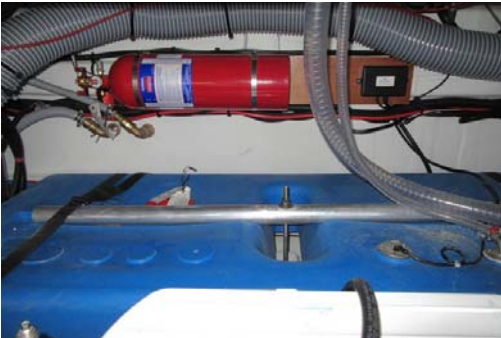

Ref 2: Remote pull switches
Location: Wheelhouse



The position of the remote control handles is indicated by the pictogram shown below:



Maintenance of the fire-fighting system

- It is the responsibility of the boat owner to invite a fire safety professional aboard every year to check the fire fighting equipment (weight and pressure of the non-portable extinguisher, correct operation of the remote operation pull switch).
- Every 5 years, the boat owner must remove the non-portable extinguisher and take it to a fire safety professional for a full overhaul in a specialist workshop.

6.4.3 Smoke alarm

General points

- The smoke detector is a photoelectric detector which operates with a 9 V alkaline battery (battery included).
- The detector emits a flashing red light every minute in normal operation.
- The smoke detector is designed to operate between 0° and + 50°C.
- Whenever any smoke is detected, the 85 dB alarm is triggered.
- The smoke detector is not designed to stop a fire from breaking out. It serves to warn the people onboard of the danger.
- The detector is a device which warns people onboard in the event of smoke.

Actions to take if the alarm is triggered: The skipper should check the source of the smoke and attempt to extinguish the fire with the resources at his/her disposal. If the fire spreads, the skipper must immediately evacuate the entire crew.

- The service life of the smoke detector is approximately 10 years. Beyond 10 years, replace the smoke detector with an identical device.

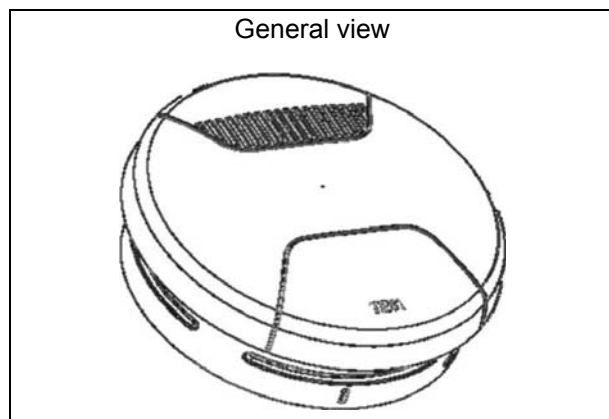

- The smoke detector is not a gas detector.
- The smoke detector is sensitive to dust and steam: avoid exposing the detector to these environments to prevent the triggering of unwanted alarms.
- Never use a rechargeable battery.
- Never trigger the alarm deliberately to check the operation of the detector.
- A dirty detector may activate incorrectly or late. It is important to clean each detector for the safety of people onboard.
- Never cover the smoke detector (with paint or ceiling panels, for example) and in general do not alter the appearance of the detector.
- Do not fit the smoke detector in a different location from the one specified for the purpose.

Wheelhouse

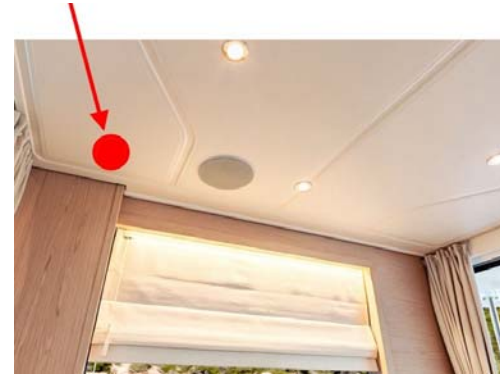
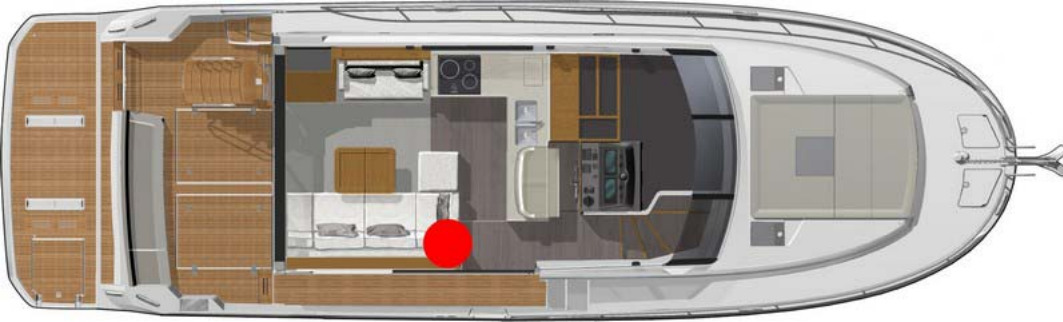

Cabins



Commissioning of the boat

- When the boat is first delivered, ensure that the battery protector is removed.

Maintenance

The smoke detector must be routinely tested when boarding or weekly if staying onboard for a prolonged period of time. If the device is faulty, change the battery. If the device is still faulty after changing the battery, replace the detector with the same model (consult your dealer).

- **TEST button**



- Regularly check that each detector is working correctly by pressing and holding the device's TEST button for around ten seconds:

- The detector's light flashes, then the alarm starts up.

NOTE: The alarm emits a very loud noise (approximately 94 dB at one metre), remember to use hearing protection during the test.

- When the TEST button is released, the alarm stops immediately.

- **Changing the battery**

- The smoke detector will emit an audible beep every minute for a month when the battery level is too low to operate.

- In that case, change the battery as described below:

- Remove the detector from its mounting (turn anti-clockwise), remove the empty battery and replace it with the same model of alkaline 9 V battery, ensuring a battery life of 5 years.

- Connect the battery as shown in its housing (ensure the battery polarity +/- is correct).

- Return the detector to its mounting (turn clockwise) until it fits perfectly.

- **Annual routine maintenance**

- Remove the detector from its housing (turn anti-clockwise) and clean the vents on the side of the device with a vacuum cleaner or a soft brush.

- Use a damp cloth to clean the exterior of the detector cover.

Winterisation

- To ensure optimal operation, it is recommended that the smoke detector is stored for winter in a fresh and well-ventilated place, having removed the battery.

- Once one person is onboard, it is important to replace the smoke detector in the position specified for the purpose, having first reinstalled the battery.

6.5 EMERGENCY EXITS IN CASE OF FIRE

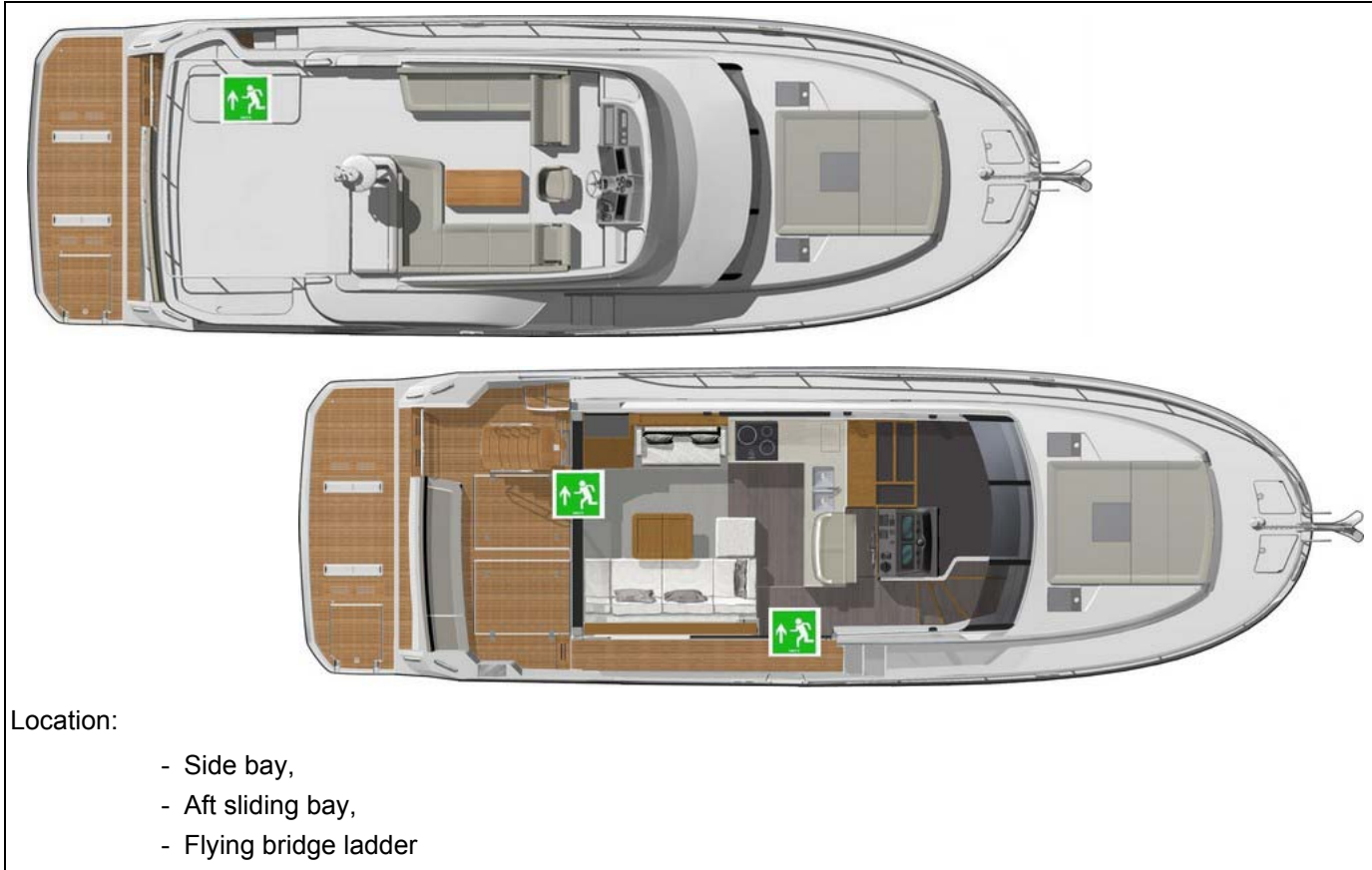

ELECTRICAL SYSTEM

■ General information about the electrical system	62
■ DC installation (12V or 24V).....	63
■ Touch screen	83
■ Ship Control.....	91
■ AC system (110V or 220V)	111
■ Protection against electrolysis / Earth plate.....	125

7.1 GENERAL INFORMATION ABOUT THE ELECTRICAL SYSTEM

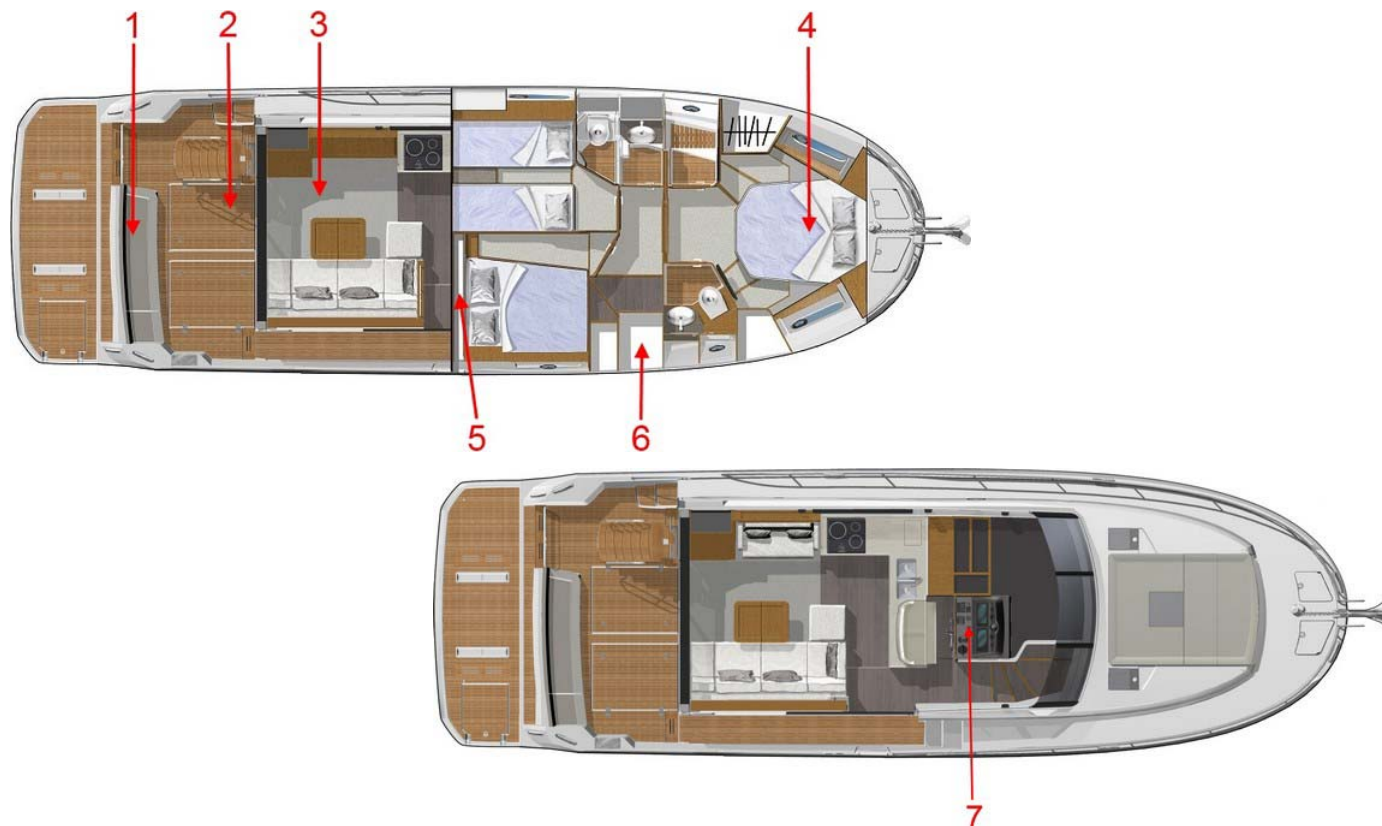

Reference	Designation
1	Stern thruster batteries
2	Generator battery
3	Service batteries & Engine batteries
4	Bow thruster batteries
5	Power unit (Battery switches, Circuit breakers, Power distributor)
6	Battery charger, Circuit breakers, Touch screen, Control of the battery breaker
7	Steering station switches

- ✘ - A risk of fire or explosion may result from careless use of the DC and AC systems.
- A risk of electrocution may result from careless use of the AC system.

- ! NEVER:
- work on a live electrical system;
 - modify the electrical system of the vessel or the relevant diagrams: It is important that installation, maintenance and any modifications be carried out by a qualified marine electrician;
 - change or modify the strength of the safety devices protecting against power surges;
 - install or replace electrical equipment or materials with components which exceed the system's nominal electrical power capacity;
 - leave the boat unsupervised when the electrical system is live, apart from when the automatic bilge pump and the boat's fire protection and security system are in use (where installed).

- ! Electrical connections change over time. It is necessary to have the boat's electrics checked regularly and at least once every two years by a professional. Special attention should be paid to the tightness of the electrical connections.

7.2 DC INSTALLATION (12V OR 24V)

7.2.1 Battery use and distribution

General points

- The boat is equipped with a direct current electrical system.
- The boat's electrical system comprises service batteries and the engine battery or batteries. The service batteries serve as the power supply for all the boat's electrical components. The "engine" battery is used only for powering the electric starter of the propulsion engine.
- The boat may also be equipped with:
 - a generator powered by its own battery;
 - a bow thruster, powered by its own battery bank;
 - A stern thruster, powered by its own battery bank.
- the batteries are charged either by a load distributor or:
 - by the alternator linked to the engine when the engine is running,
 - by the battery charger.
- It is essential that a professional engineer connects the batteries when the boat is first launched.
- Always check the condition of the batteries and charge system before putting to sea.
- The battery banks are isolated from one another by a charge divider (see below).

Battery bank

Engine battery: 4 x 50A (12V circuit)
Location: Engine compartment

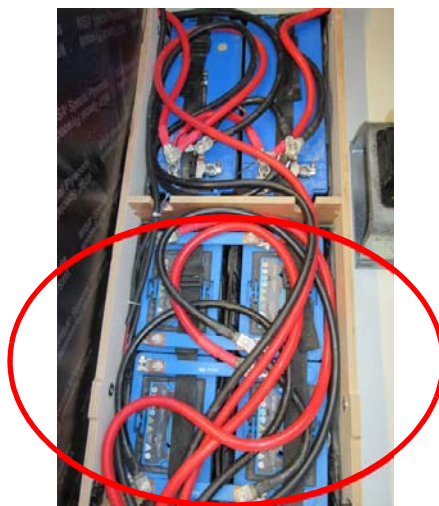

Generator battery: 115A (12V circuit)
Location: Cockpit locker



Service batteries: 2 x 140A (12V circuit)
Location: Engine compartment

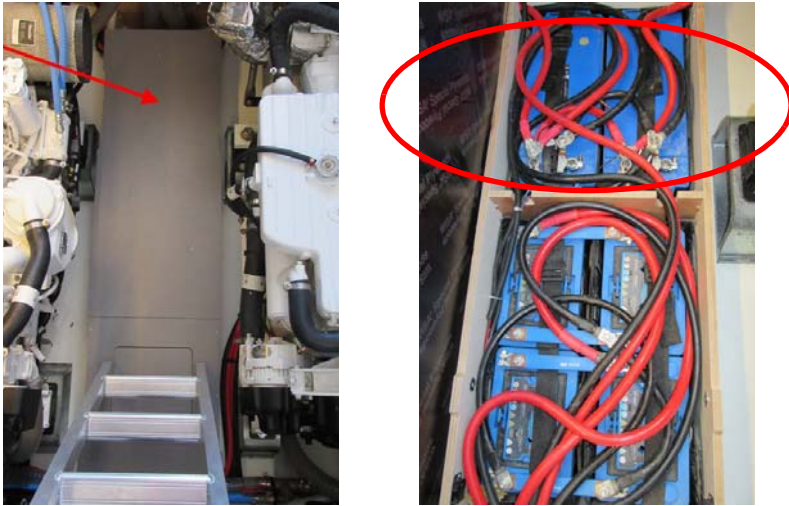

Spare service batteries: 2 x 140A (12V circuit)
Location: Engine compartment

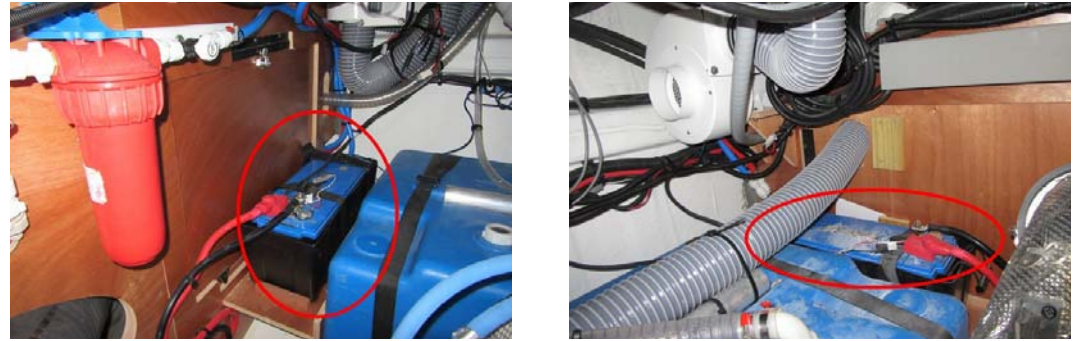

Bow thruster battery: 4 x 50A (24V circuit)
Location: Forward cabin



Poop thruster battery: 4 x 50A (24V circuit)
Location: Cockpit locker



Maintenance

- Keep the batteries clean and dry.
- Regularly check that the terminals and connection cables are clean. If necessary, apply a thin coating of paraffin on the terminals to prevent corrosion.
- Regularly recharge all of the batteries onboard.
- Keep the batteries charged at all times: this will improve their lifespan.
- Avoid long periods of electrical inactivity (for example when wintering the boat).

Maintenance of lead batteries

- Check the water levels in the batteries annually and top them up with distilled water if they are low.
- Keep all metallic objects away from the batteries.
- Lead batteries contain sulphuric acid: be careful not to knock them over whenever handling them.

Maintenance of watertight batteries

- This type of battery needs no maintenance and does not produce any gas during normal use. No ventilation is needed.
- The optimum temperature for use is between 10°C and 30°C. Lower temperatures will reduce the available capacity. Higher temperatures will increase the batteries' self-discharge rate.
- Never open watertight batteries.
- Never add acid or distilled water.
- The pressure valves are used to seal the batteries and cannot be opened without being permanently broken.
- If the batteries overheat, a build-up of gas may develop: stay away from the batteries.



- All work carried out on a battery must only be carried out by someone qualified to do so. Whenever working on a battery, wear safety goggles and protective clothing.
 - Never smoke or produce a spark near a battery: this may cause an explosion.
 - If any acid accidentally splashes on your skin or in your eyes, rinse it off immediately and thoroughly with fresh water. See a doctor immediately.
 - Never touch the battery terminals: you may suffer an electric shock.
 - Refer to the manufacturer's instructions for use and maintenance.
 - **It is essential that you disconnect the battery charger before disconnecting the battery terminals for maintenance (either by disconnecting the AC shore power socket or by cutting the AC circuit breaker of the battery charger).**

7.2.2 Battery switches

Electrically controlled battery isolators: press the switches on the breaker control panel. In the event of electrical failure, it is possible to press the button on top of the battery breaker down manually to activate it.

- The electrically-controlled battery breakers use very little electricity when they are on: **it is essential to turn off all the battery breakers during lengthy absences to prevent the batteries from slowly and irreversibly discharging.**
- The engine's positive battery isolator automatically switches on and off when the engine is started/stopped.
- The negative of the circuit is connected to the general negative.

Location: Starboard aft cabin (Power unit)



1. Starboard engine positive isolator switch
2. Port engine positive isolator switch

3. Service batteries positive isolator switch
4. Common battery negative isolator switch

Power unit access: Bedhead



NOTE: The cupboard door opens with a magnet.



- Turn off all battery isolators before leaving the vessel: **failure to do so may result in critical damage to the entire battery bank.**
- Avoid touching the battery isolators when they are live.
- Never switch off the battery isolators when the boat's engine is running (risk of serious damage to the charging circuit).

Positive isolator switch (Bow thruster)



Positive isolator switch (Bow thruster)



- 1. Generator negative isolator switch
- 2. Generator positive isolator switch

Control panel for electrically controlled battery breakers

Location: Companionway

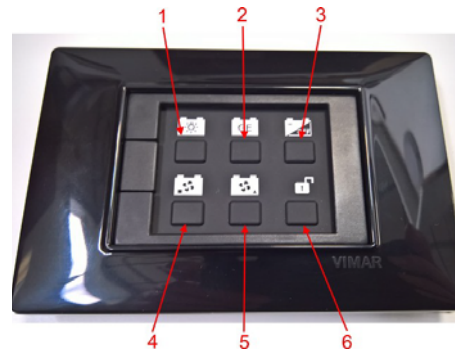

- 1. Service battery positive switch control
- 2. Switch not connected
- 3. Common battery negative isolator control
- 4. Port engine battery positive isolator control
- 5. Starboard engine battery positive isolator control
- 6. Lock switch

Operation of the control panel:

- A locking switch prevents accidental operation of the battery isolator control panel.
- To enable battery switch operation, press the lock switch. The white light then illuminates on the lock switch and on all of the battery cut-off switches. This means that control of the battery switches is enabled.
- Activate the push button of the battery isolator you wish to operate: the red warning light comes on. This means that the battery switch is ON.
- To turn off the battery isolator, press the push button again: when the red light is off, it means that the battery isolator is OFF.

Operation of the remote control:

- A radio remote control makes it possible to operate battery switches remotely.
- Pressing the remote control switches on the service batteries' positive and the common battery's negative. It is not possible to turn on the engine battery switch with the remote control. When the battery switches are turned on, the buzzer sounds once.
- Pressing the remote control turns off all the battery switches (service, engine and negative). When the battery switches are closed, the buzzer sounds twice.



7.2.3 Power distributor

- The electronic charge dividers isolate the battery banks from each other and allow the charge to be directed automatically to the battery with the lowest charge. They provide the advantage of preventing a drop in voltage.
- The charge divider is electronic. It is designed to distribute the charging current with a low voltage drop between the battery banks (engine and service batteries). It prevents the current from circulating from one battery to another. When the voltage of the charger or alternator is available, the charge divider indicator lights up green.
- The load distributor is integrated in the power unit.

Location: Starboard aft cabin (Power unit)



7.2.4 Connection of the battery bank

If one of the engine batteries is low on power, use the battery link function by actuating the linking system.

Linking switch

Definition:

- The coupling switch is a momentary relay.

Operation:

- Hold the switch down until the motors start up, then release.

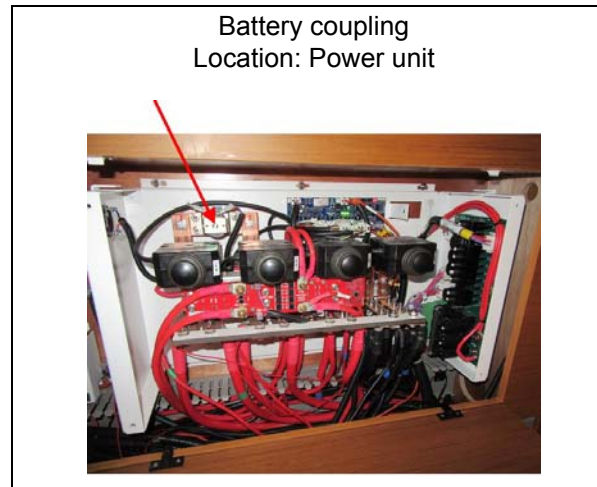
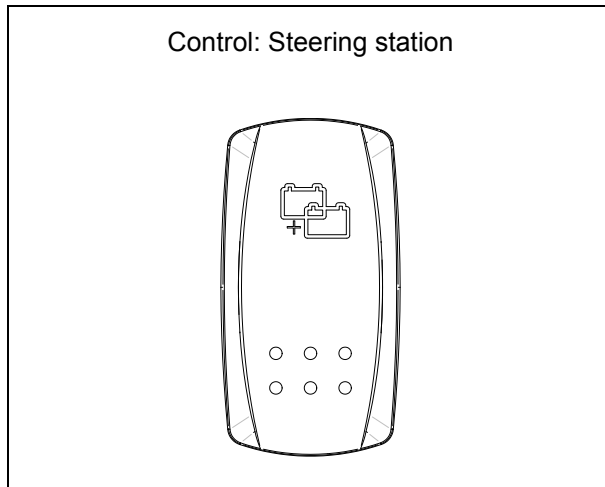

7.2.5 Battery charger

General points

- The battery charger runs on AC power.
- A breaker protects the electrical circuit.
- The battery charger charges all of the batteries onboard while keeping the service battery bank isolated from the engine's battery bank.

Operation

- The charger runs fully automatically. It can stay permanently connected to the batteries and does not need to be disconnected when starting the engine.
- In some electrical circuits, there may be battery chargers coupled in parallel.
- The chargers transmit information specific to the batteries to which they are connected.
- The chargers give the value of the supply voltage (220V or 110V).
- The chargers give the battery voltage even if they are OFF when the CAN network is switched on.
- Chargers are power-controllable (for load shedding).

Maintenance

- Before doing any maintenance, cut the AC supply.
- Regularly vacuum out any dust particles which may accumulate in the charger. An annual check of the tightness of the nuts and bolts is necessary to ensure the correct operation of the charger.



It is essential that you disconnect the battery charger before disconnecting the battery terminals for maintenance (either by disconnecting the AC shore power socket or by cutting the AC circuit breaker of the battery charger).

Servitude & engine battery charger (12V circuit)
Location: Companionway

Power: depending on the equipment of your boat

- 40A & 25A
- or
- 25A & 25A



Generator battery charger
(12V circuit)



Bow thruster battery charger
(24V circuit)



Stern thruster battery charger
(24V circuit)



DIAGRAM OF LAYOUT - WIRING OF THE 12 V DC BATTERIES

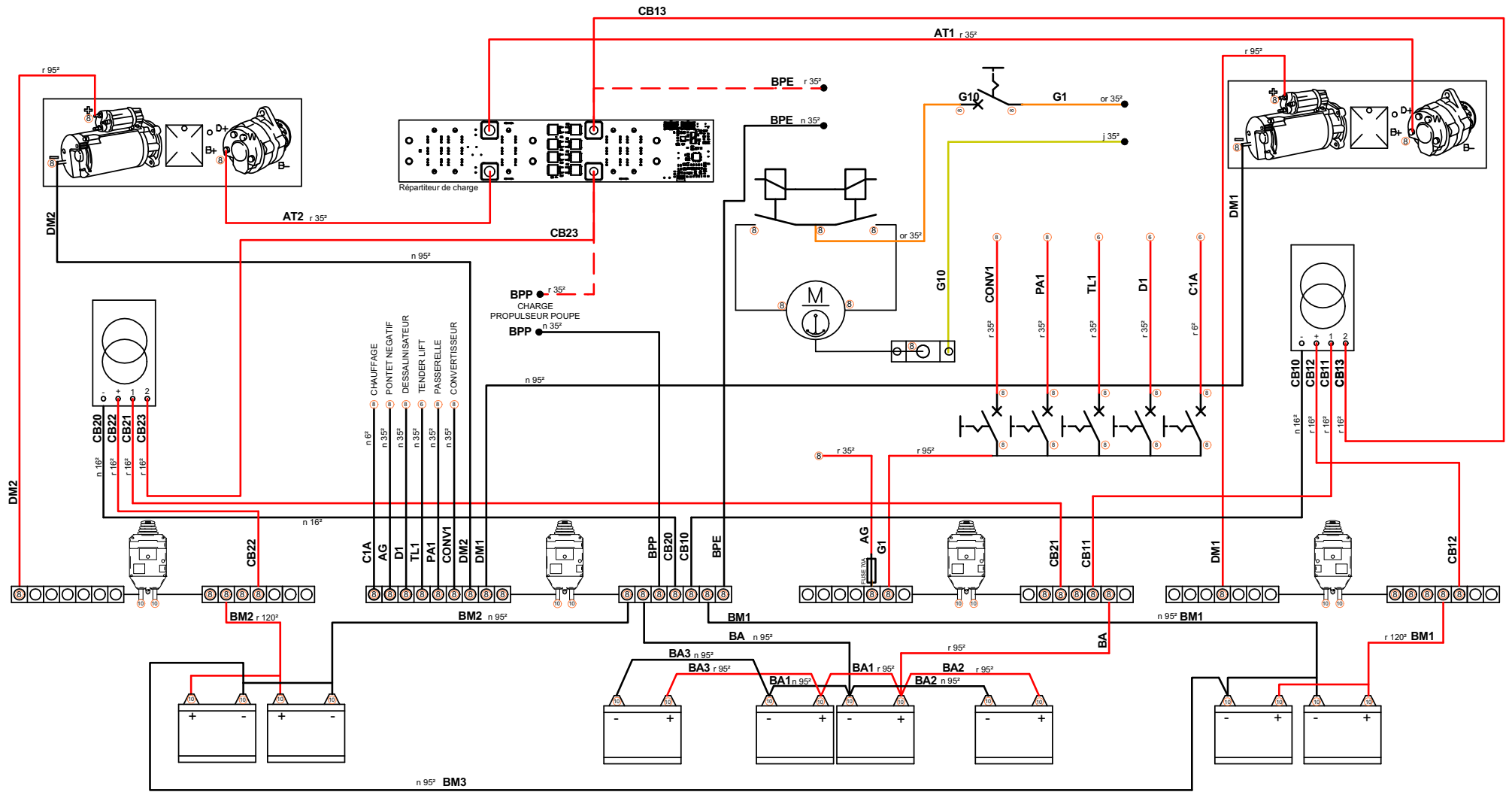

7.2.6 Layout of hull wiring looms - DC circuit

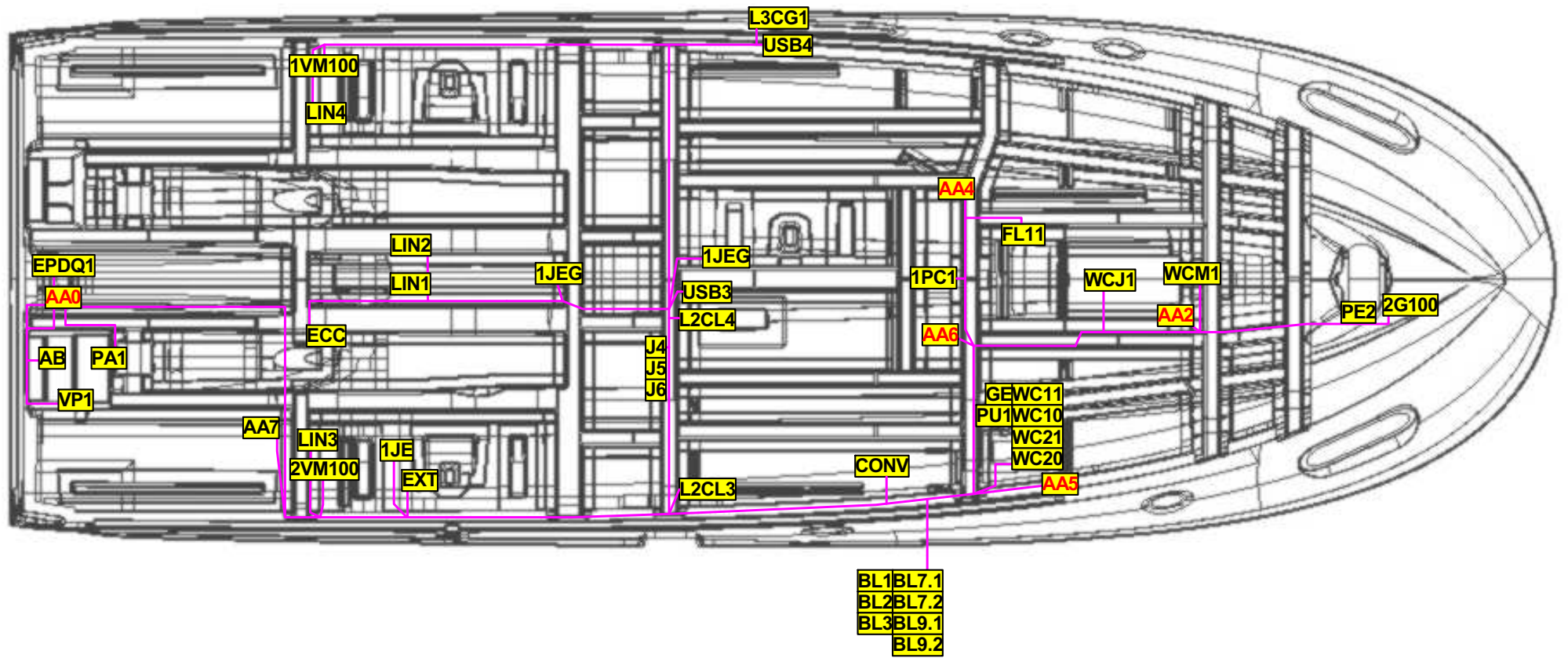

7.2.7 Plan of beams of the hull counter-moulding - DC circuit

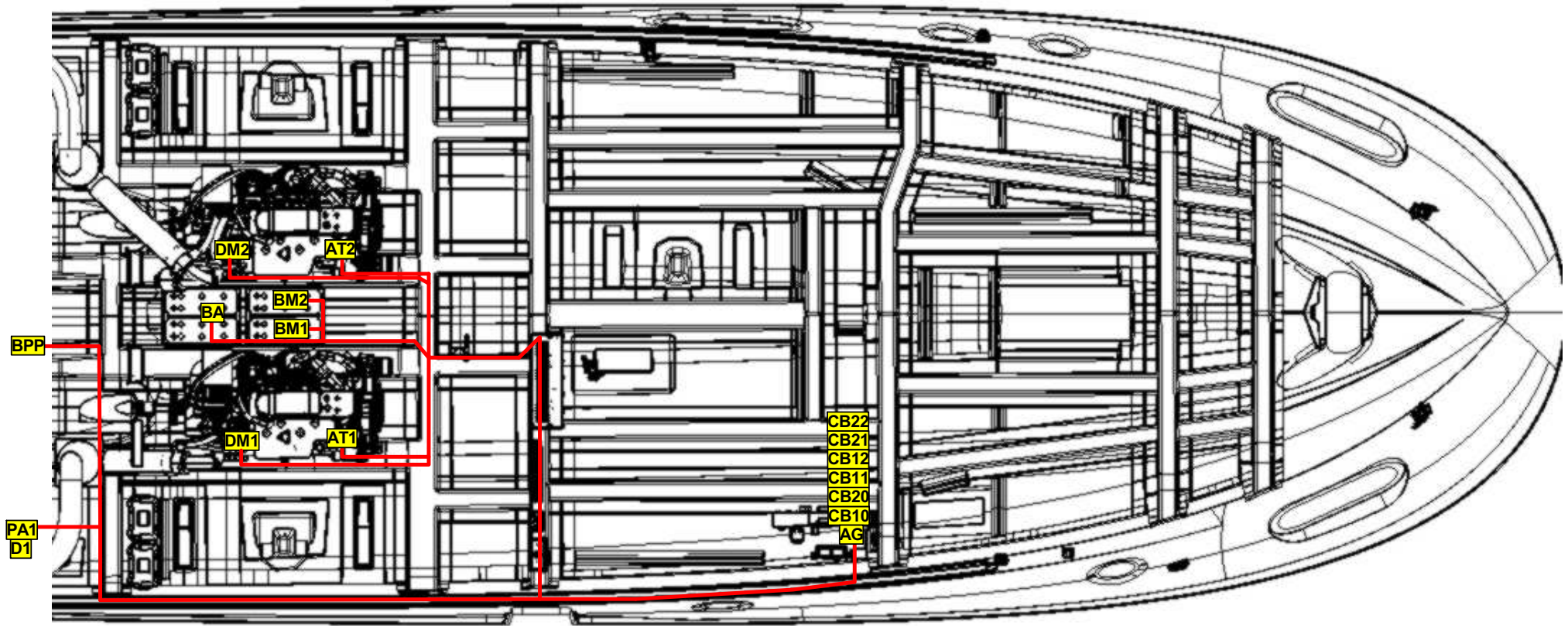

7.2.8 Layout of deck wiring looms - DC circuit

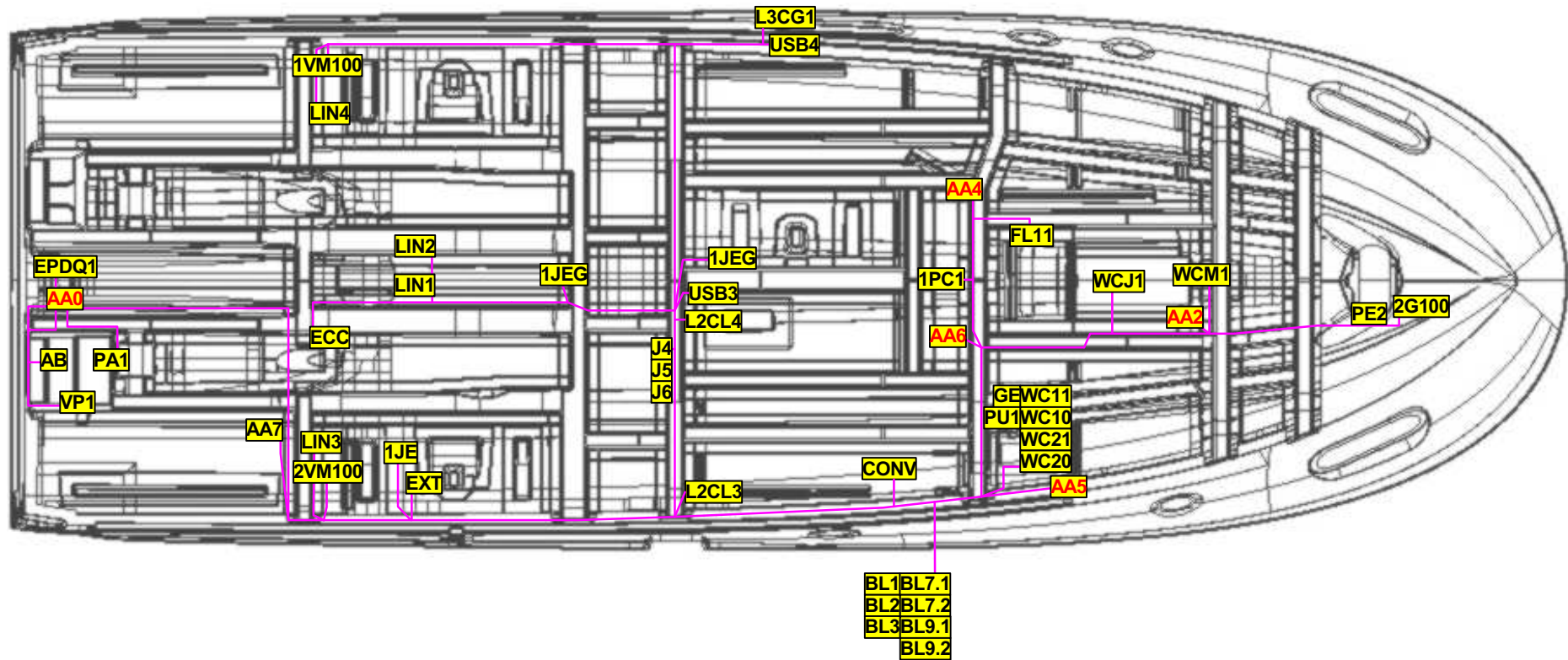

7.2.9 Layout of wiring looms in the deck backing moulding - DC circuit

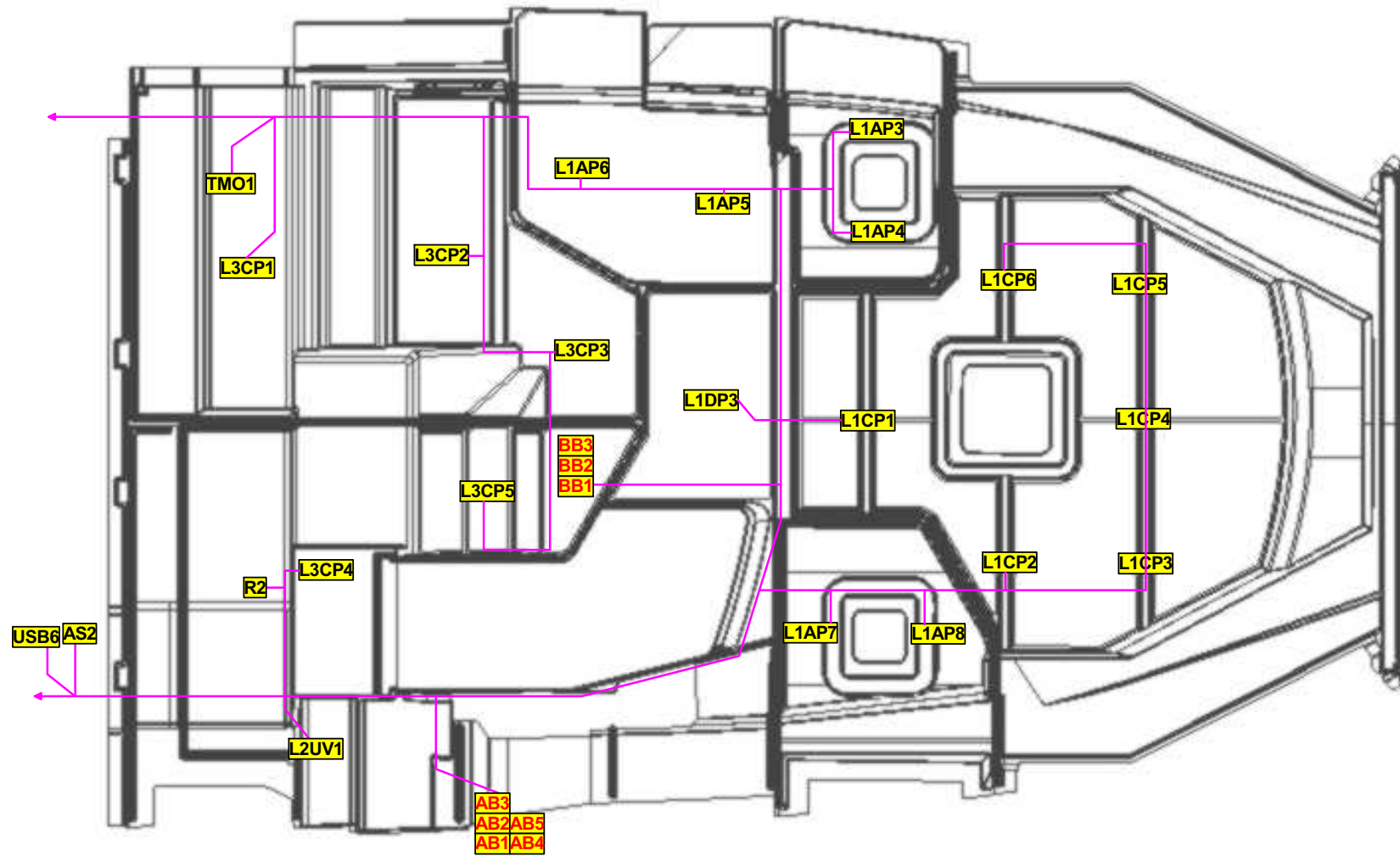

7.2.10 Diagram of flying bridge inner moulding wiring looms - DC circuit



7.2.11 Switches

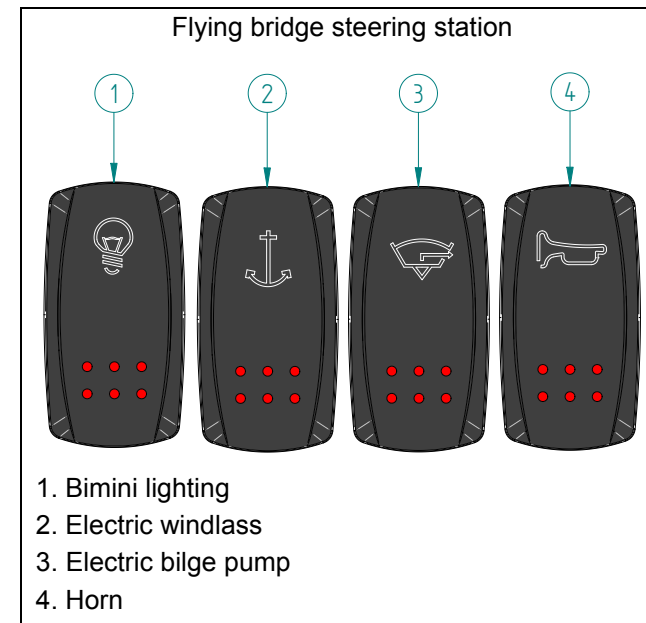
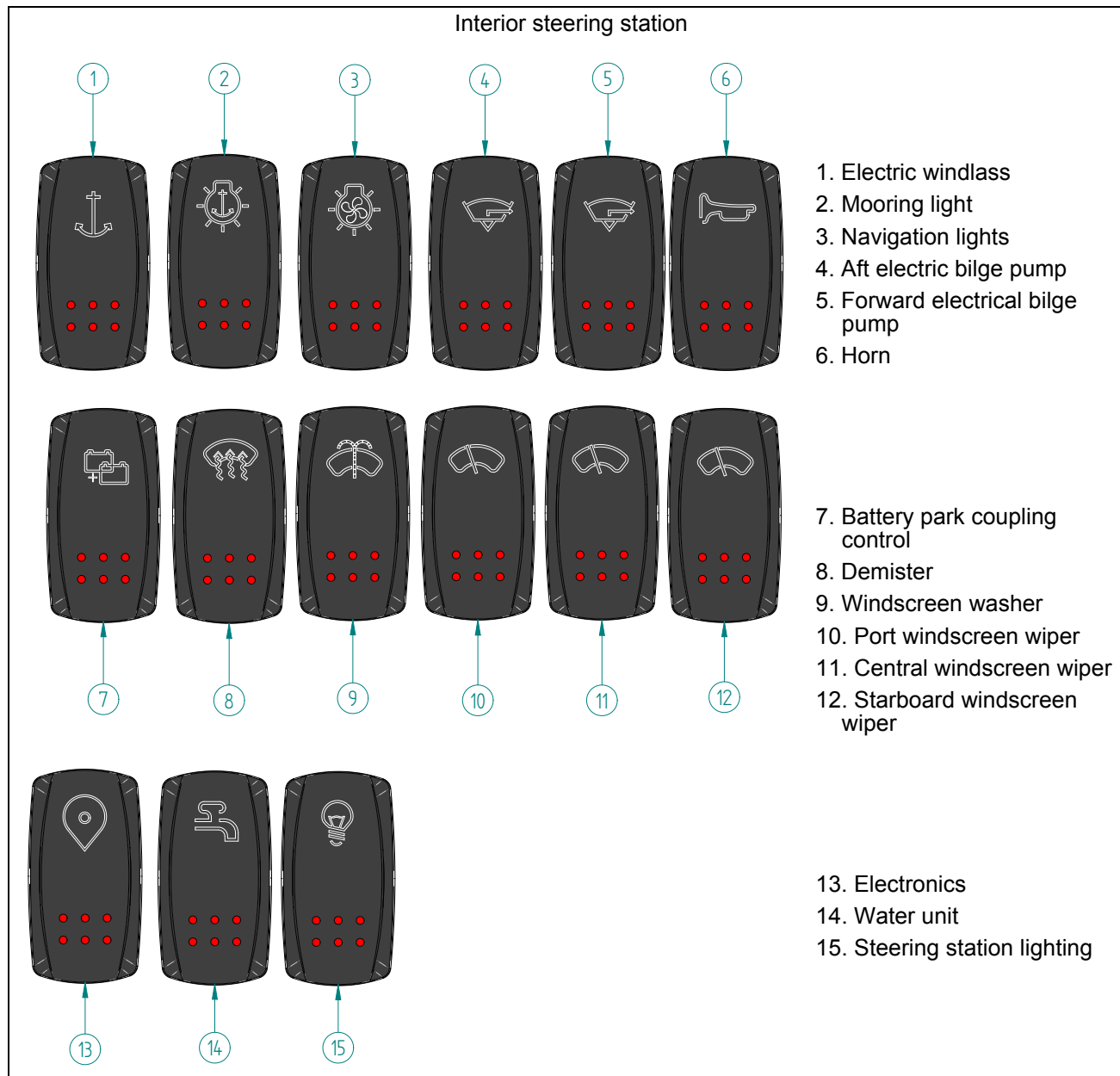

7.2.12 Circuit breakers

A circuit-breaker can be reset (manually press the black button to restart it).

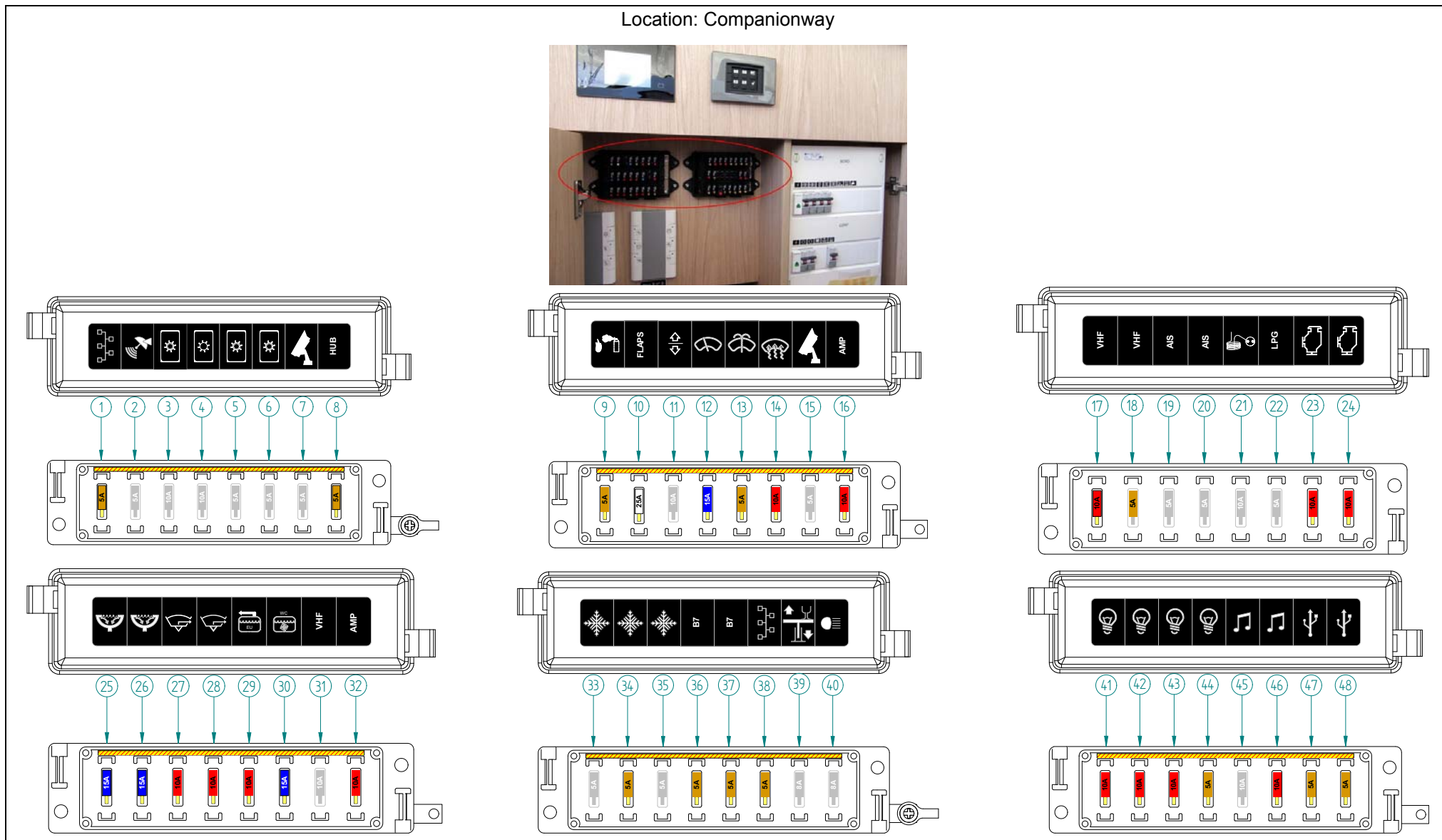

Reference	Designation
1	System - Electronics
2	Radar
3	Touch screen (Wheelhouse)
4	Touch screen (Wheelhouse)
5	Touch screen (Flying bridge)
6	Touch screen (Flying bridge)
7	Rear camera
8	HUB
9	Control - Fixed extinguisher
10	Flaps
11	Sun roof
12	Wiper
13	Windscreen washer
14	Demister
15	Thermal imaging camera
16	Auxiliary
17	VHF (Wheelhouse)
18	VHF (Flying bridge)
19	100 AIS
20	650 AIS
21	AC shore power socket reel (US Version)
22	Gas solenoid (US Version)
23	Control box (Motor)
24	Control box (Motor)

Reference	Designation
25	Control - Starboard WC
26	Control - Port WC
27	Forward electrical bilge pump
28	Aft electric bilge pump
29	Waste water drain pump
30	Macerator (Pump for drainage of the blackwater tank to the sea)
31	VHF
32	Auxiliary
33	Fridge (Flying bridge)
34	Fridge (Galley)
35	Fridge (Galley)
36	Measuring block (n°1)
37	Measuring block (n°2)
38	Supply - Ship Control network
39	Electric table pedestal
40	Deck searchlight
41	Lighting (n°1)
42	Lighting (n°2)
43	Lighting (n°3)
44	Lighting (Engine compartment)
45	HiFi (Forward cabin)
46	HiFi (Wheelhouse)
47	USB socket (Cabin)
48	USB socket (Wheelhouse & Flying bridge)

Location: Power unit (Electrical protection fuses)

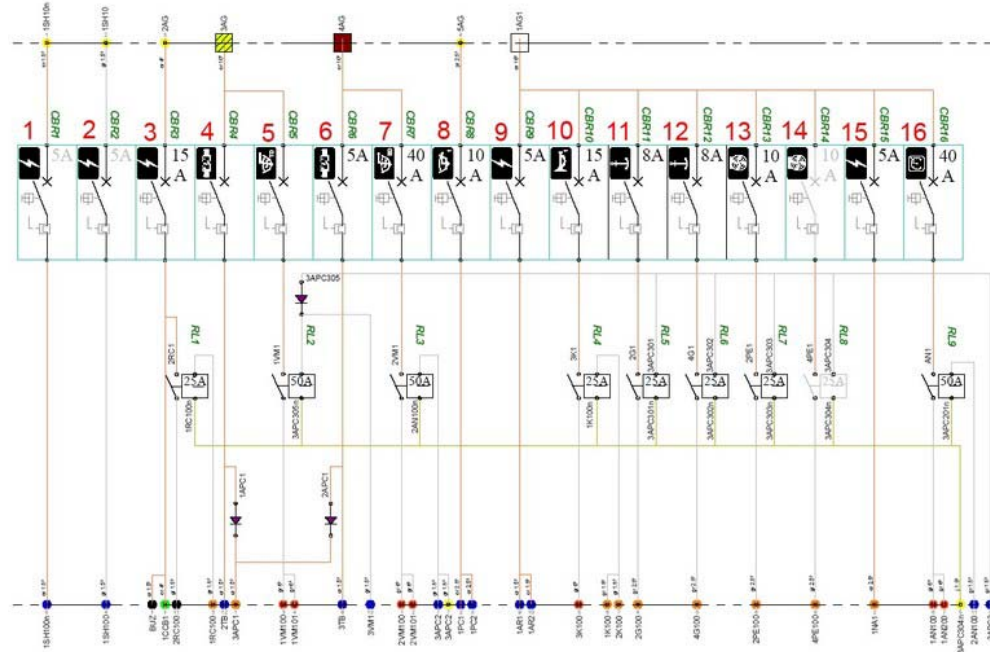

1. Shunt 1
2. Shunt 2
3. Battery switch control supply
4. Starboard plus after-contact
5. Starboard bilge fan
6. Port plus after-contact
7. Port bilge fan
8. Electric bilge pump
9. Horn and defogger control
10. Horn
11. Electric windlass control
12. Flaps
13. Bow thruster control
14. Stern thruster control
15. Navicolor touchscreen
16. Electronics

Location: Aft cabin



- 200A: DC/AC converter
- 135A: Passerelle
- 120A: Tender lift
- 50A: Watermaker

! When replacing fuses/circuit-breakers, always ensure replacements are of the correct capacity (see the colour-codes)

20A	15A	10A	5A	3A
-----	-----	-----	----	----

7.3 TOUCH SCREEN

The screen NAVICOLOR is a touch interface for viewing and controlling the auxiliary functions of the boat:

- Fuel level,
- Fresh water level,
- Greywater level,
- Blackwater level (WC),
- Battery voltage,
- Wireless lighting,
- Starting the generator,
- Management of boat's AC supply sources,
- Network viewing and diagnostics.

Location: Companionway



TOUCH SCREEN OPERATION

Front view:

1. Direct access to home page
2. Previous page
3. ON/OFF button
4. Tank menu
5. Back
6. Light sensor
7. Next page
8. Direct access to battery page



Rear view:

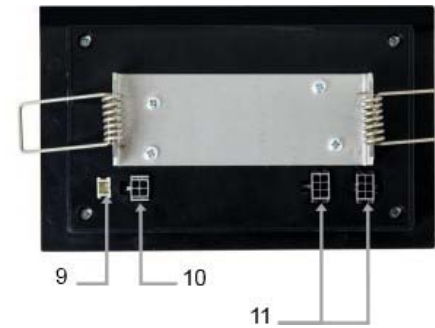

9. Connector for temperature sensor
10. Bus
11. CAN connector



Battery measurement menu access



Fresh water tank level menu access



AC supply distribution menu access



Interior lighting menu access

Adjustment menu access (Access to it is restricted by a code supplied on request to the yard)



- CAN network display (Controller Area Network)
- Parameterization of lighting
- Configuration of the 'gauge' pack
- Configuration of source selectors



Return to preceding page

Operation

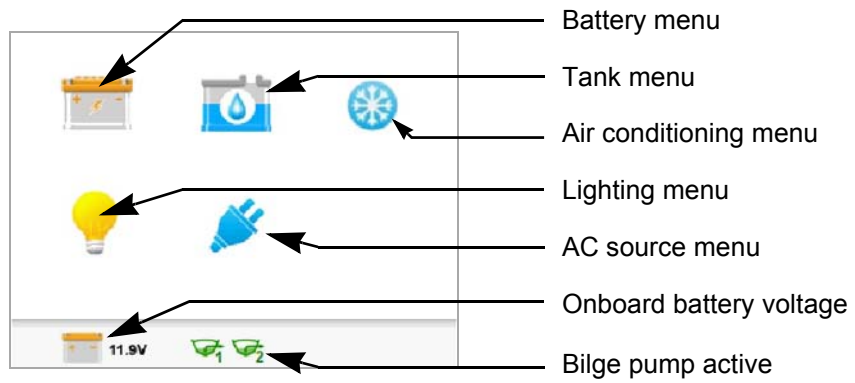

The menu may vary depending on the specific equipment of each boat.

Battery menu



Access sub-menus by pressing the required menu icon.

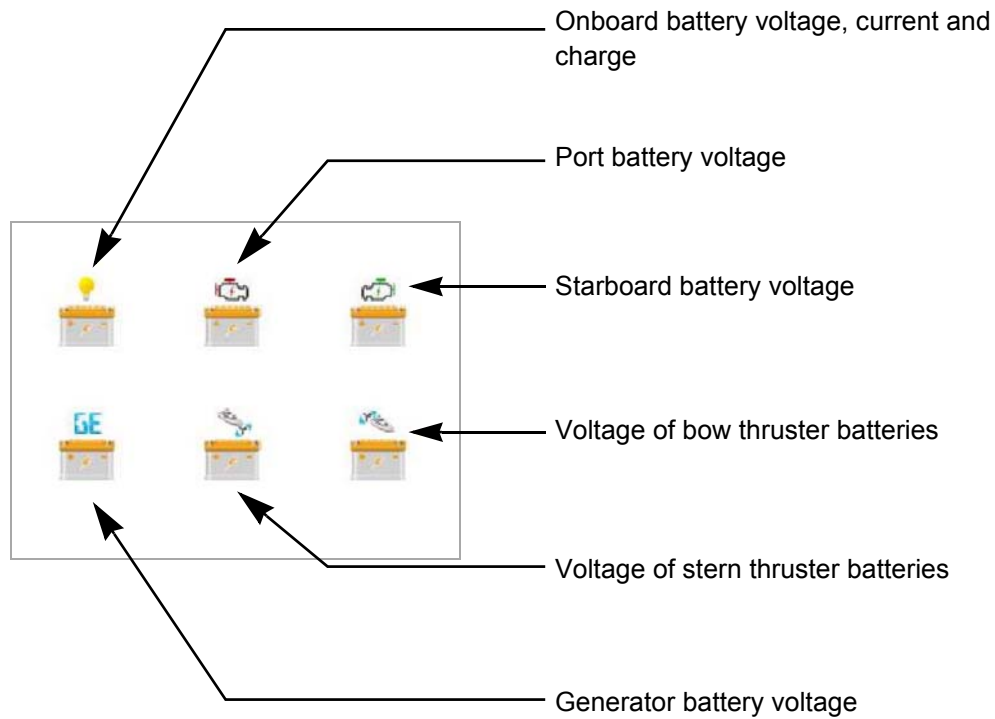

examples:

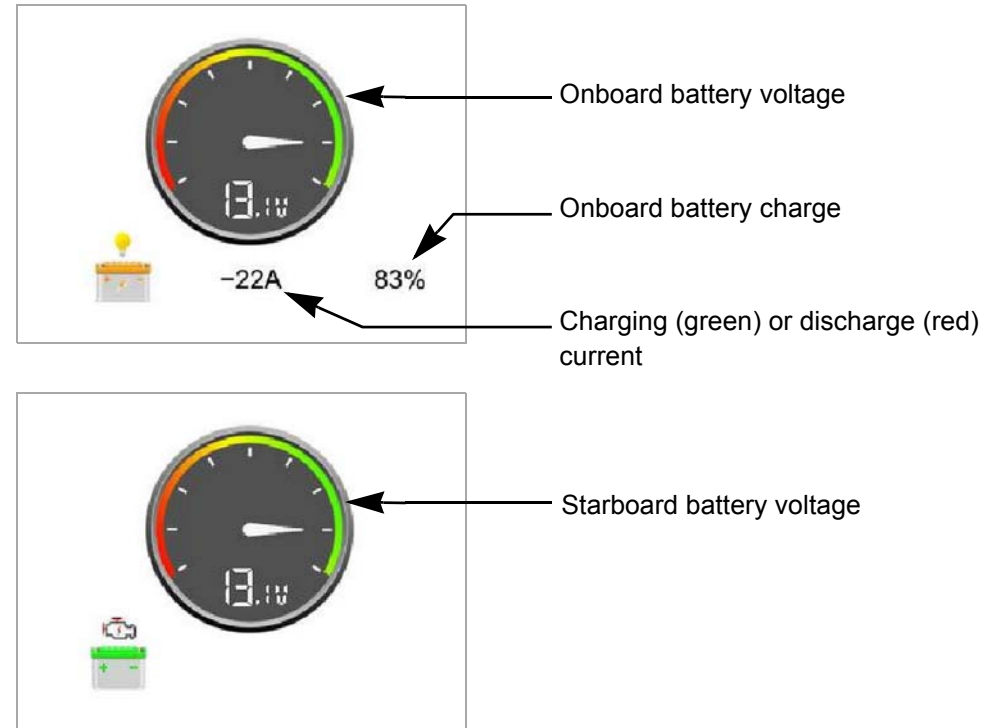

Tank menu



Access sub-menus by pressing the required menu icon.

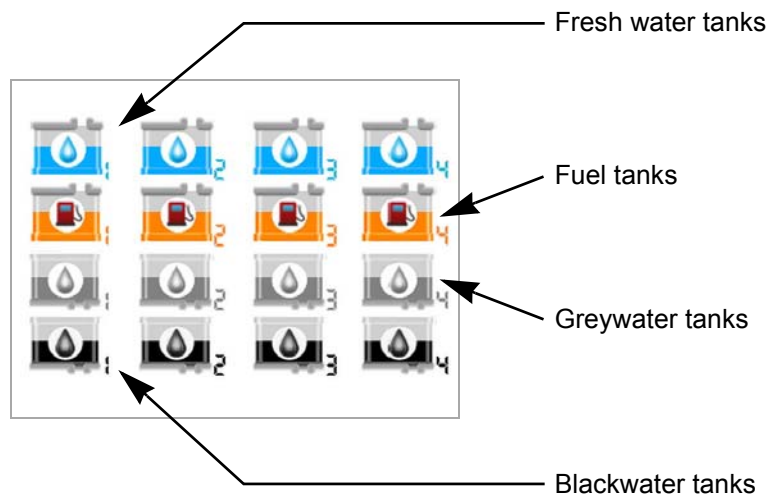

examples:

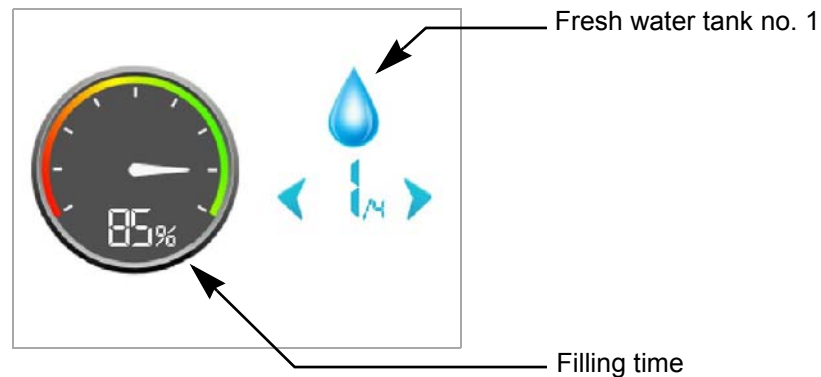

Air conditioning menu

The Navicolor controls the air conditioning in the saloon.

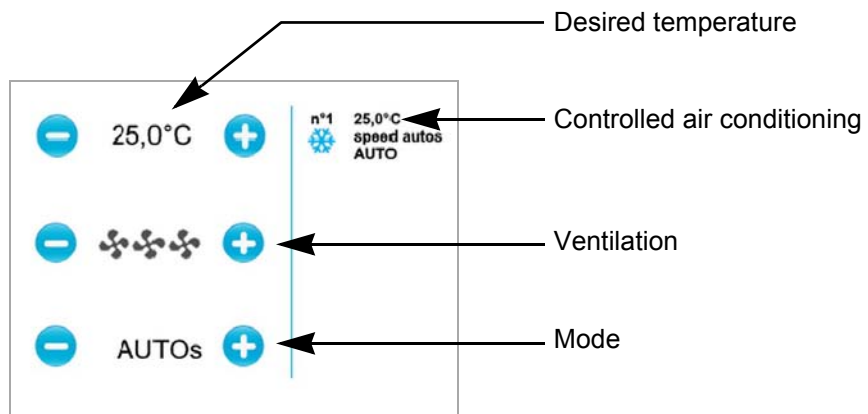

Lighting menu



Access sub-menus by pressing the required menu icon.

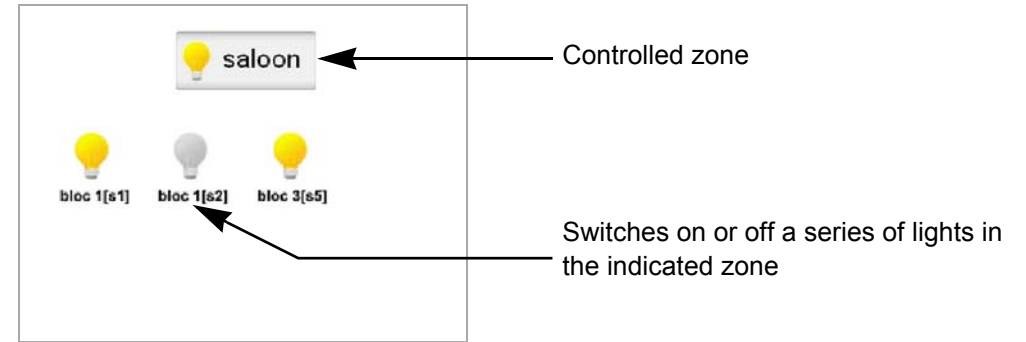
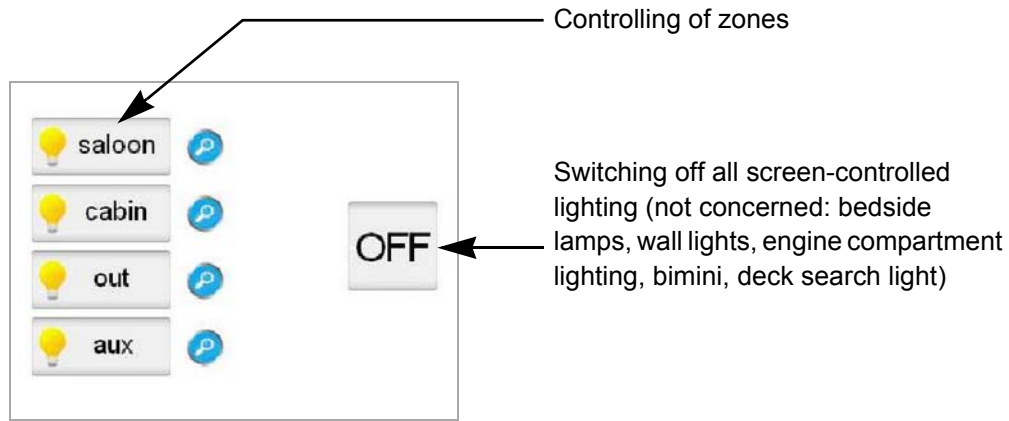

AC source menu



Access sub-menus by pressing the required menu icon.

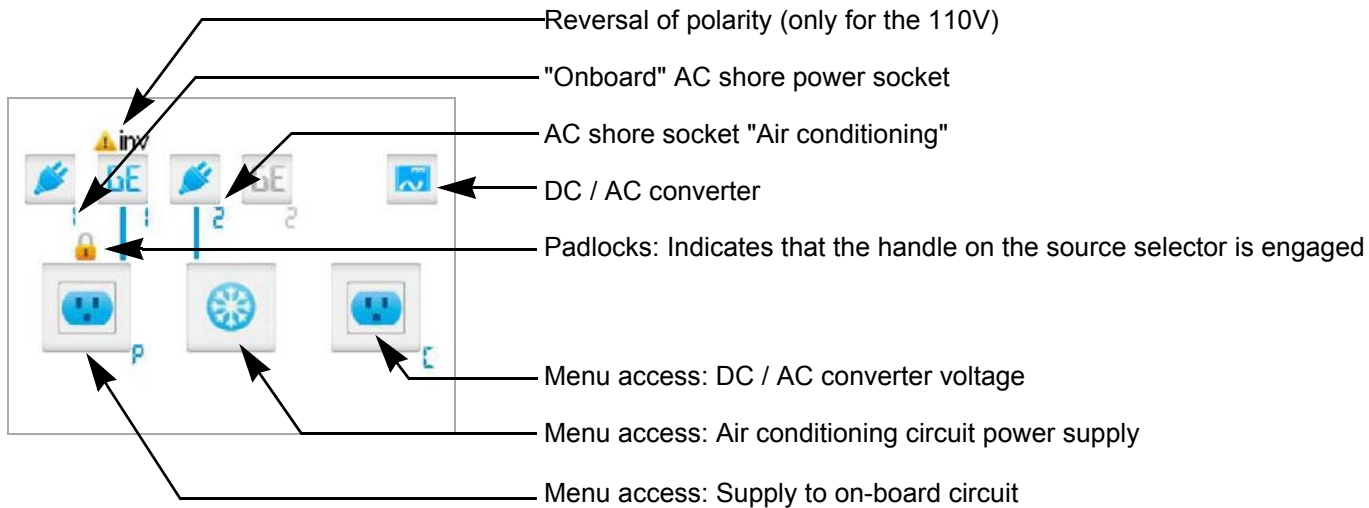

AC source menu

One press of the shore supply button sets the onboard selector switch to shore supply or generator. An orange circle indicates that the switch has been made.

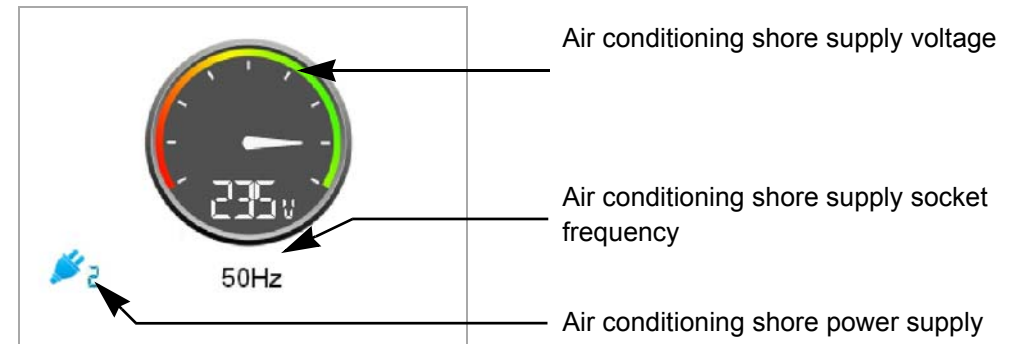
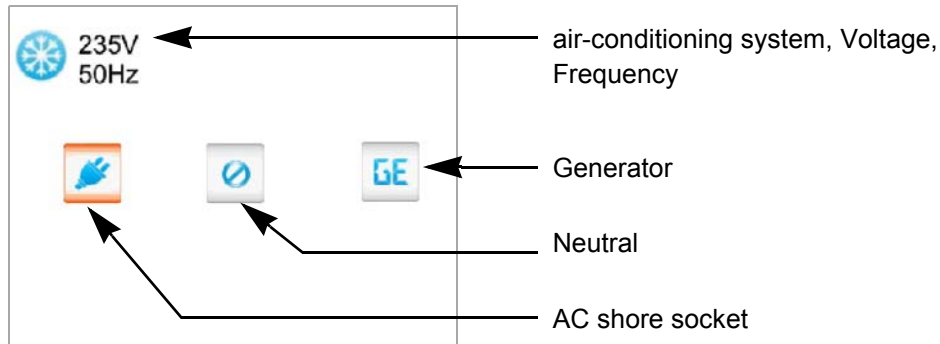
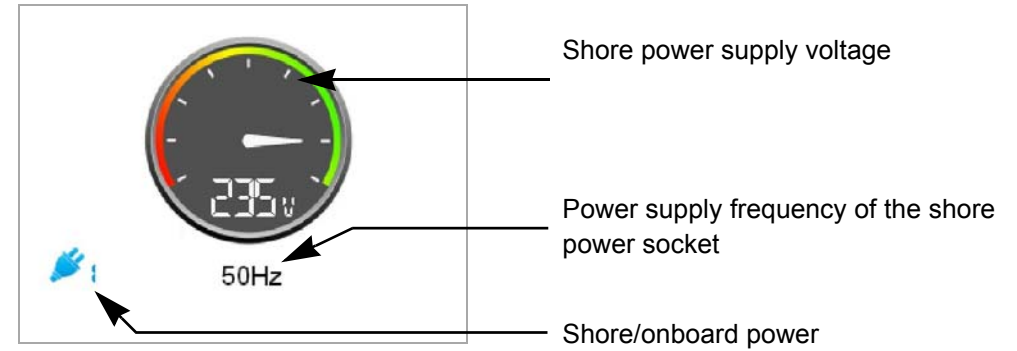
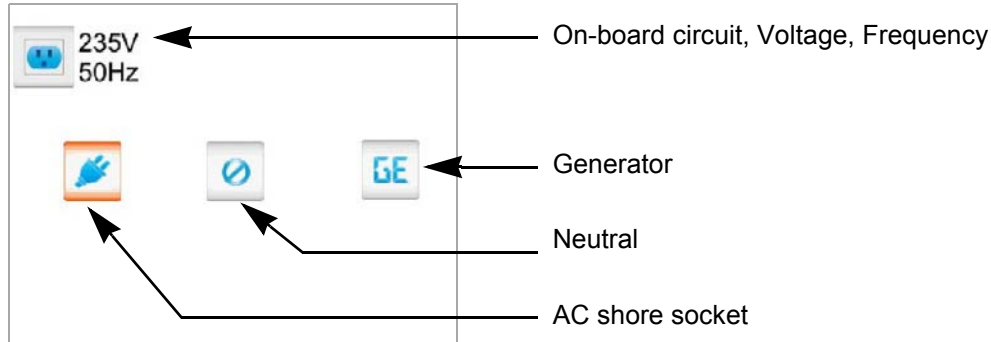

AC source menu

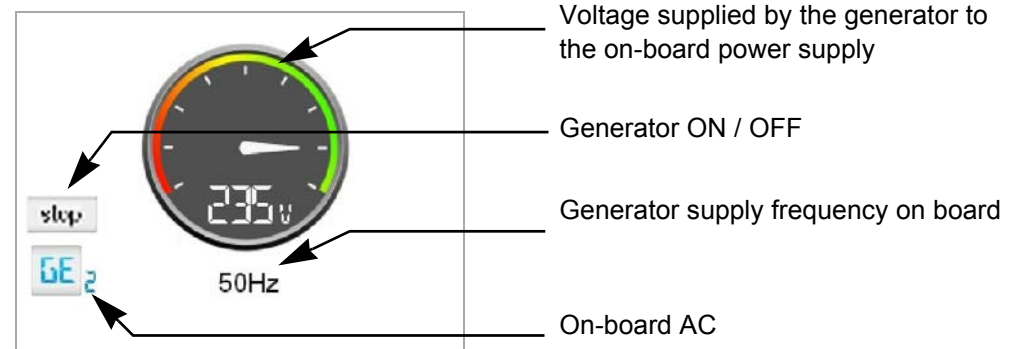
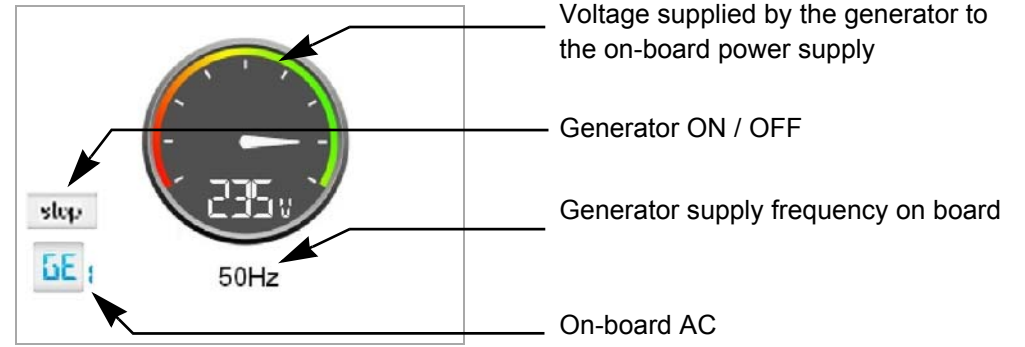
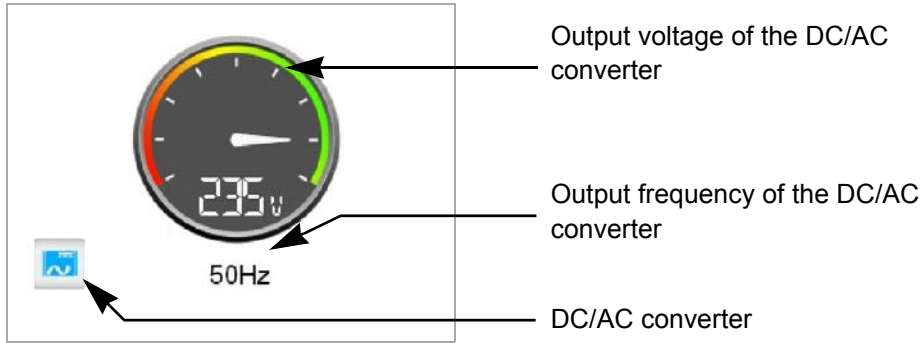

7.4 SHIP CONTROL

7.4.1 Introduction

The Ship Control is an interface that allows access to all the on-board electrical systems via the navigation screen or a tablet connected to the boat's internal WiFi. Based on multiplexing, Ship Control controls navigation, engine and fluid data. It is also possible to:

- control lighting, HiFi, air conditioning,
- manage AC power sources and bilge pumps.

Ship Control is not an application but an interface accessible via a web address and solely from the boat's WiFi and the navigation screens.

Each interface is protected by a password: it is not possible to take control of the Ship Control of a neighbouring boat.

NOTE: For proper system operation, the NMEA 2000 bus must not be connected to a device not provided for by Ship Control. Refer to manual SHIP CONTROL provided by SPBI-BENETEAU.

Any intervention (software or hardware) on the installation or parameter setting of an electronic equipment or accessory connected to Ship Control can lead to its malfunction. Installation of electronic equipment or NMEA 2000 accessories not validated by SPBI-BENETEAU may result in system failure Ship Control.

Since the system Ship Control can remotely control certain boat functions (eg. windlass, bilge pumps, navigation lights), access to the system Ship Control by a third party must be under the authority and responsibility of the skipper.

Warning! This manual must be read carefully to know how the system works Ship Control.

SPBI-BENETEAU shall never be liable for any damages or prejudices of any kind resulting from non-compliance with these instructions.

In the event of user negligence (in particular, use that is not in accordance with these instructions or insufficient maintenance of the system), SPBI-BENETEAU releases itself from any liability and can in no way be held liable for the system's compliance.

7.4.2 Connection by WiFi to Ship Control

The WiFi connection is made only between the Ship Control interface and the boat's WiFi connection.

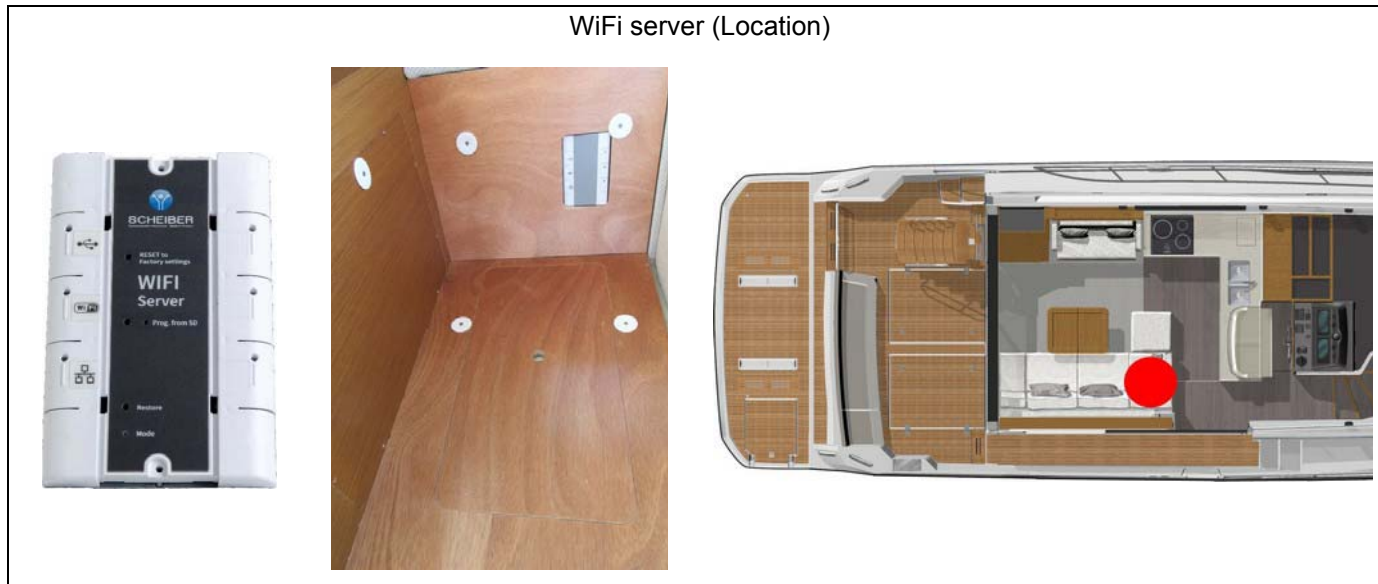

The WiFi server:

- contains the Ship Control interface,
- sends the interface and its contents to the navigation screens (via an Ethernet connection) and to a tablet (via WiFi),
- serves as CAN / NMEA 2000 gateway for connection to the navigation system.





The WiFi server hosts the Ship Control interface and sends it to the internet browsers of your phone or tablet. Under no circumstances must it be used for internet access.



Several people can connect to the server at the same time by WiFi. The skipper is responsible for the persons connected to the Ship Control interface and their actions.

To log into the Ship Control interface from a tablet or phone:

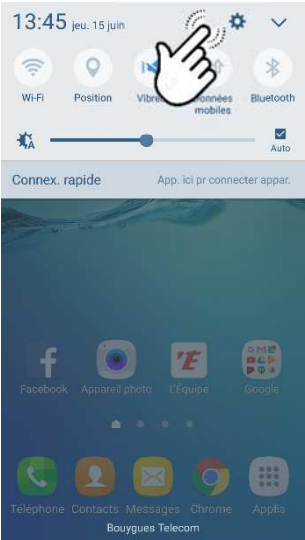
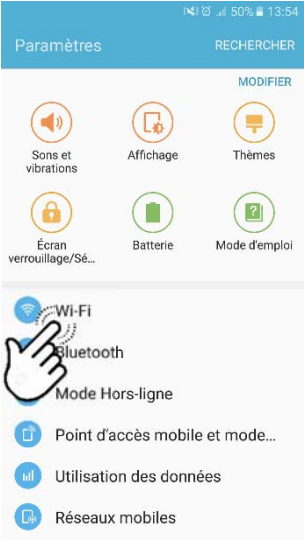
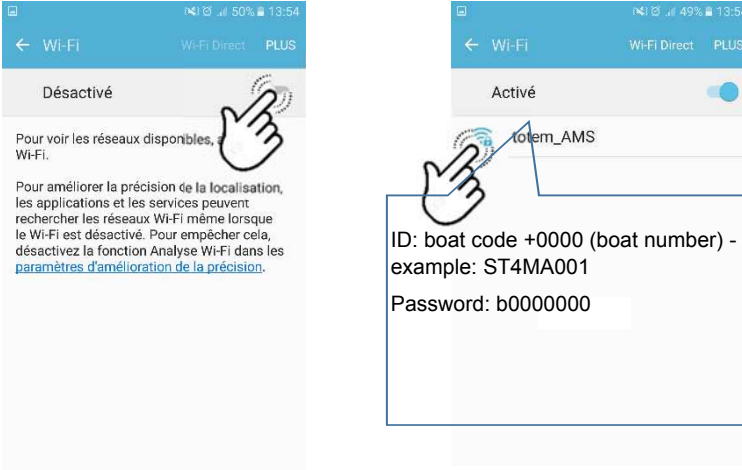
- Prerequisite: The QR app must be loaded onto your tablet or phone.
- Ship Control is optimised for Android systems.

<p>Press the "settings" icon:</p> 	<p>Select WiFi connection:</p> 	<p>Activate WiFi connection:</p>  <p>ID: boat code +0000 (boat number) - example: ST4MA001 Password: b0000000</p> <p>The password is case-sensitive</p>	<p>Scan the QR code with your tablet or phone:</p> 
---	--	---	--

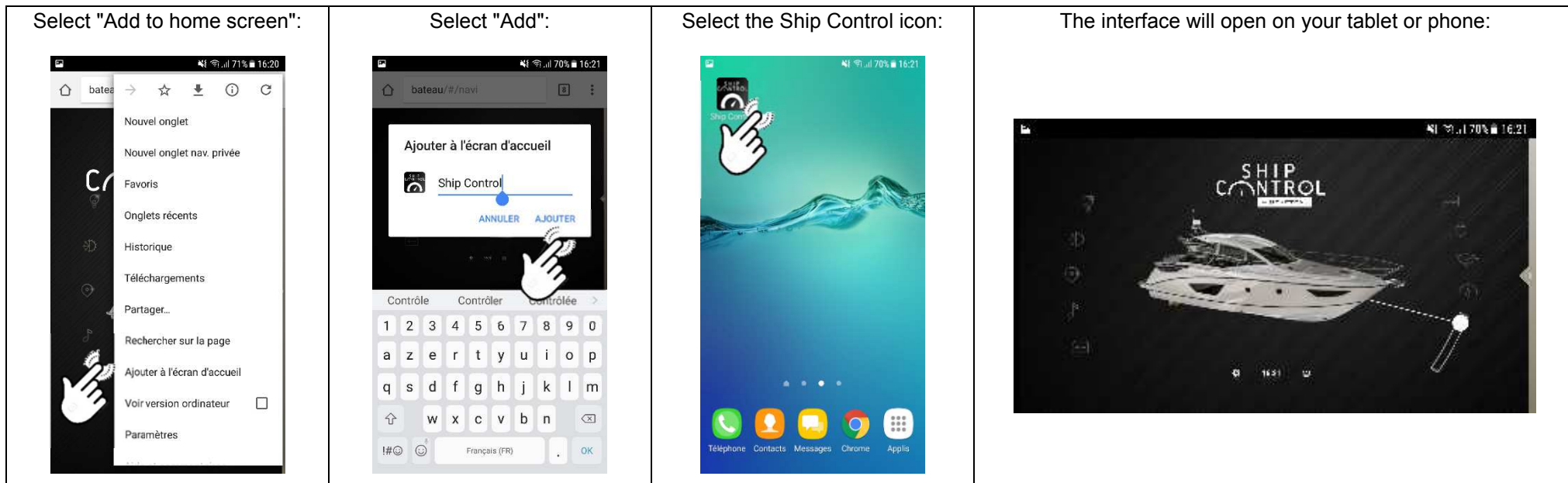

To log into the Ship Control interface from a computer:

- Select the boat's WiFi network.
- Connect to Chrome: <http://shipcontrol>

NOTE: Chrome does not accept https addresses. Only http addresses are accepted. If an address is not accepted, remove the "S" from the "http" address.

Password change procedure

- It is advisable to customise your password when logging in for the first time.

⚙ To change password, press the "Settings" symbol, then "WiFi access" . The username and password must have at least 8 characters.

How to reset the password to the factory setting

- Press the Restore button of the Web server.



Changing password

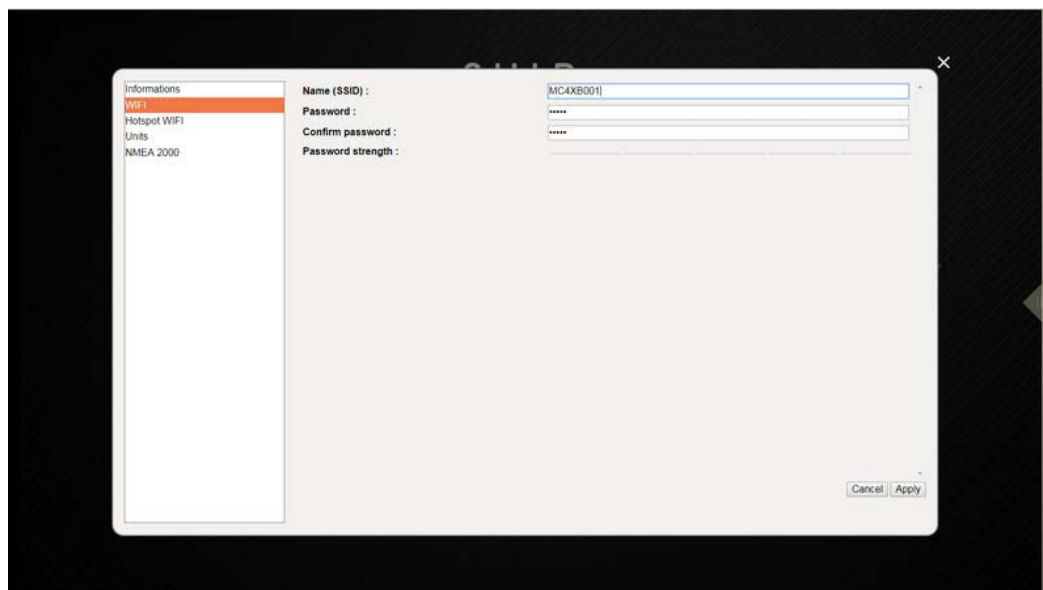





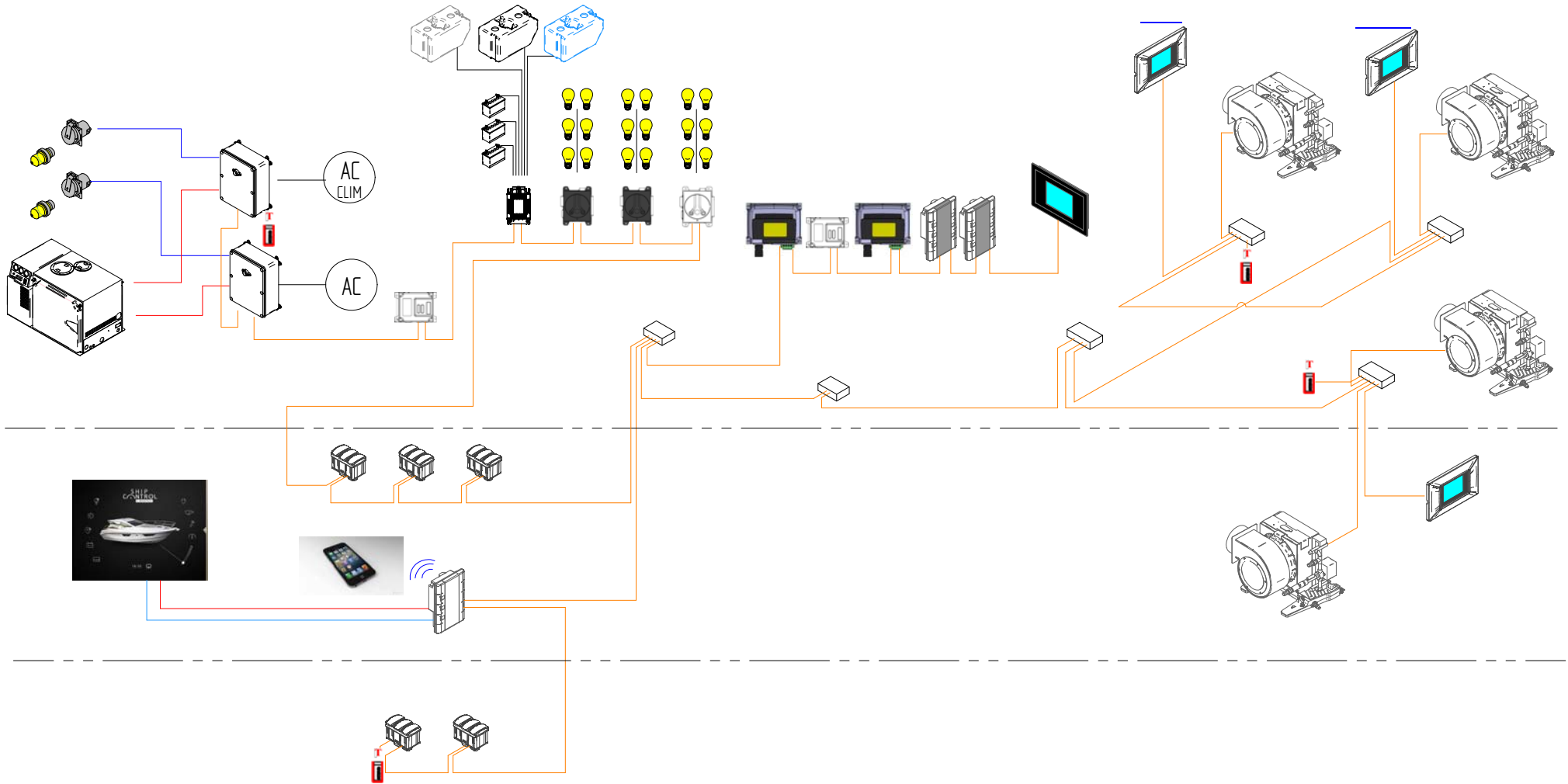



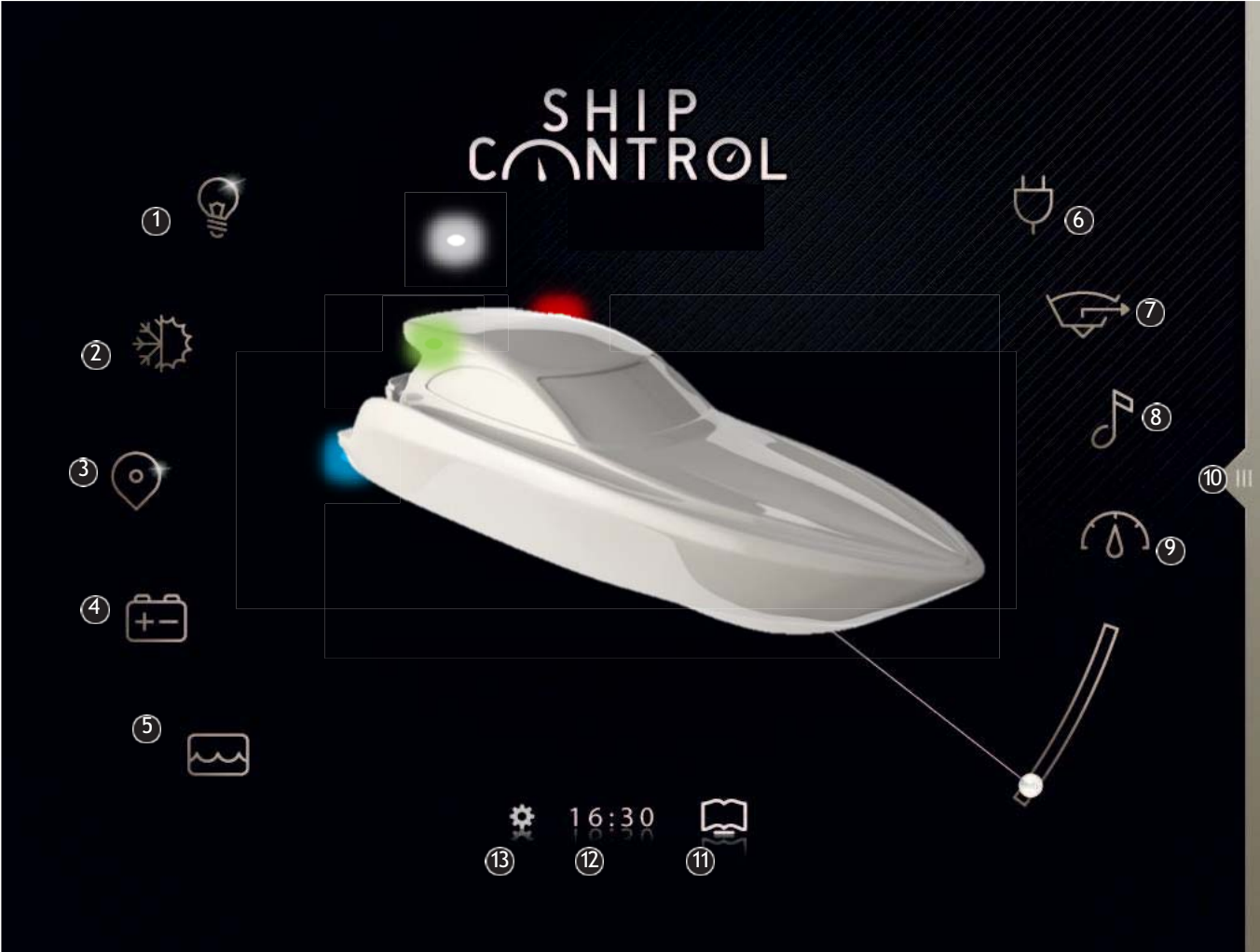



- The WiFi name and password will then be reset to the factory setting:
 - Username: ST4MA001
 - Password: b0000000
- You can now follow the password change procedure as explained in the previous paragraph.

GENERAL PRINCIPLE DIAGRAM OF THE NETWORK - SHIP CONTROL



YOUR INTERFACE



- ①  To access:
Lighting control
- ②  To access:
Air conditioning control
- ③  To access:
Navigation
- ④  To access:
Battery level control
- ⑤  To access:
Liquid level check
- ⑥  To access:
AC source control
- ⑦  To access:
Bilge pump control
- ⑧  To access:
HIFI control
- ⑨  To access:
Engine check
- ⑩  To access:
Switching
- ⑪  Access to the
Interface manual
- ⑫ 16:30 **Hour**
- ⑬  **Settings**
Units - Languages - Wifi access

7.4.3 Navicolor touchscreen

Navicolor 3'5" touchscreen

Depending on the equipment and settings specific to your boat, the 3'5" touch screen is an interface for viewing and controlling certain auxiliary functions of the vessel.

The Navicolor is used to display all the available data on the onboard CAN network:

- tank levels (fresh water, greywater, blackwater and fuel),
- batteries: voltage, current and charge,
- AC circuit: voltage and frequency,
- the condition of the bilge pumps.

The Navicolor controls:

- wireless lighting,
- generator start and AC source control via the shore / generator switch,
- air conditioning.

Location: Companionway



NOTES



The switches are stand-alone and operate without wires: they are automatically supplied with electricity by means of "PIEZO" technology.

Each switch turns a lighting outlet on and off.

Each switch is fitted with a dimmer.

The switches do not require any particular maintenance. To clean them, simply wipe over the surface of the switch with a clean, damp cloth.

Navicolor 2'4" touchscreen

The 2'4" touch screen is an interface for viewing the data available on the onboard CAN network.

- tank levels (fresh water, greywater, blackwater and fuel),
- batteries: voltage, current and charge,
- AC circuit: voltage and frequency.



Battery menu

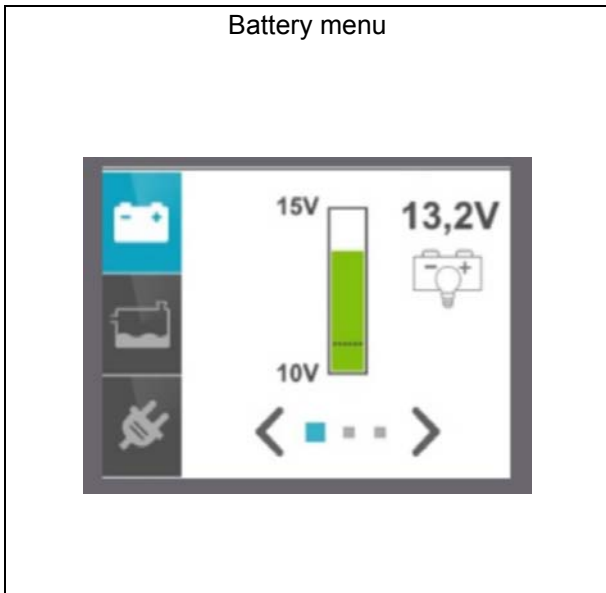

Tank menu

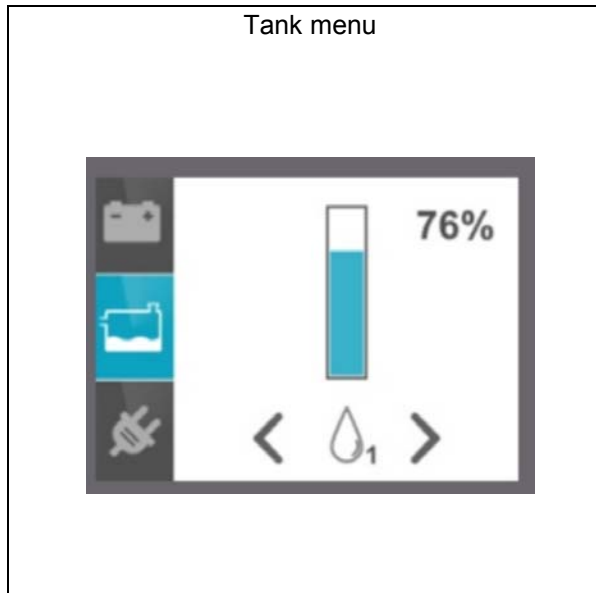

AC menu

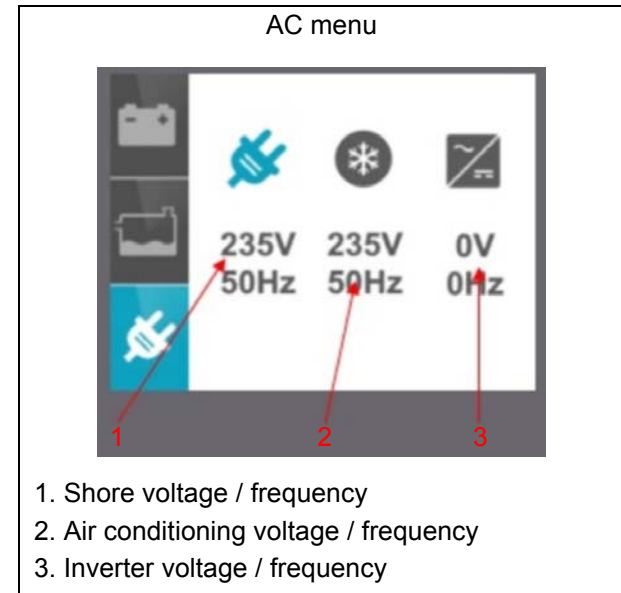

1. Shore voltage / frequency
2. Air conditioning voltage / frequency
3. Inverter voltage / frequency

DIAGRAM OF LAYOUT - LIGHTING

Deck



A	Pilot light (Exterior)
	Overhead light - Cockpit
B	Overhead light - Wheelhouse
	Garland - Wheelhouse
C	Overhead light - Wheelhouse
	Garland - Wheelhouse
D	Overhead light - Galley
	Overhead light - Cockpit
E	Overhead light - Companionway
	Pilot light (Interior)

Cabins

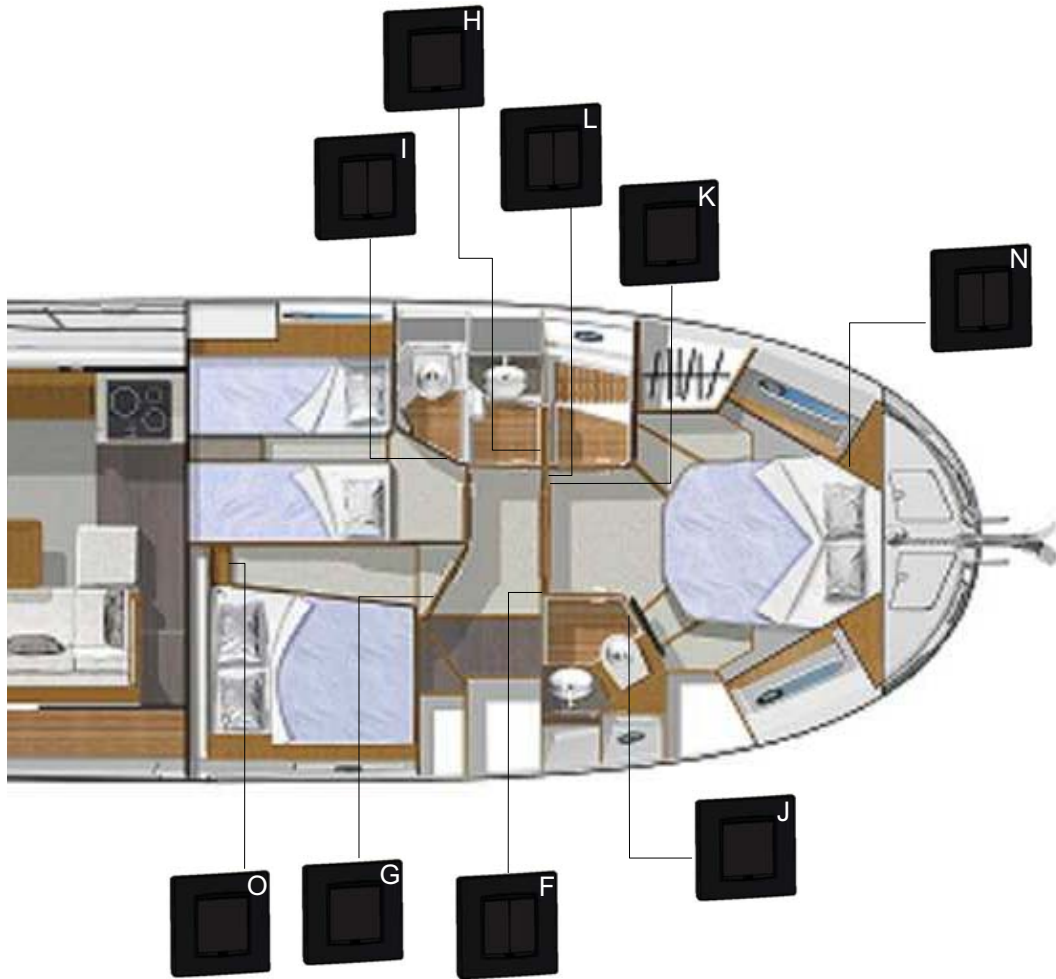

F	Overhead light - Companionway
	Pilot light (Interior)
G	Overhead light - Starboard aft cabin
H	Overhead light - Aft starboard head compartment
I	Overhead light - Port aft cabin
	Garland - Port aft cabin
J	Overhead light - Starboard forward head compartment
K	Overhead light - Port forward washroom
L	Overhead light - Forward cabin
	Overhead light - Forward cabin
N	Overhead light - Forward cabin
	Garland - Forward cabin
O	Overhead light - Starboard aft cabin

LAYOUT OF COMPONENTS

Hull

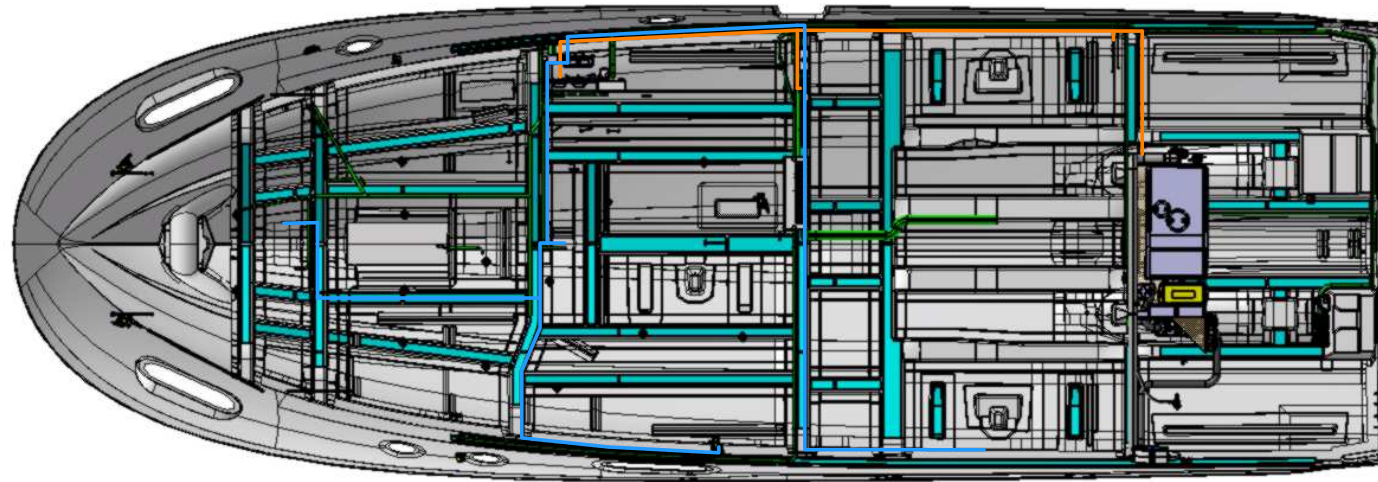

- Liaison CAN BUS Scheiber STD
- Reseau CAN BUS Scheiber STD
- Reseau CAN BUS Scheiber CLIM + ATOLL

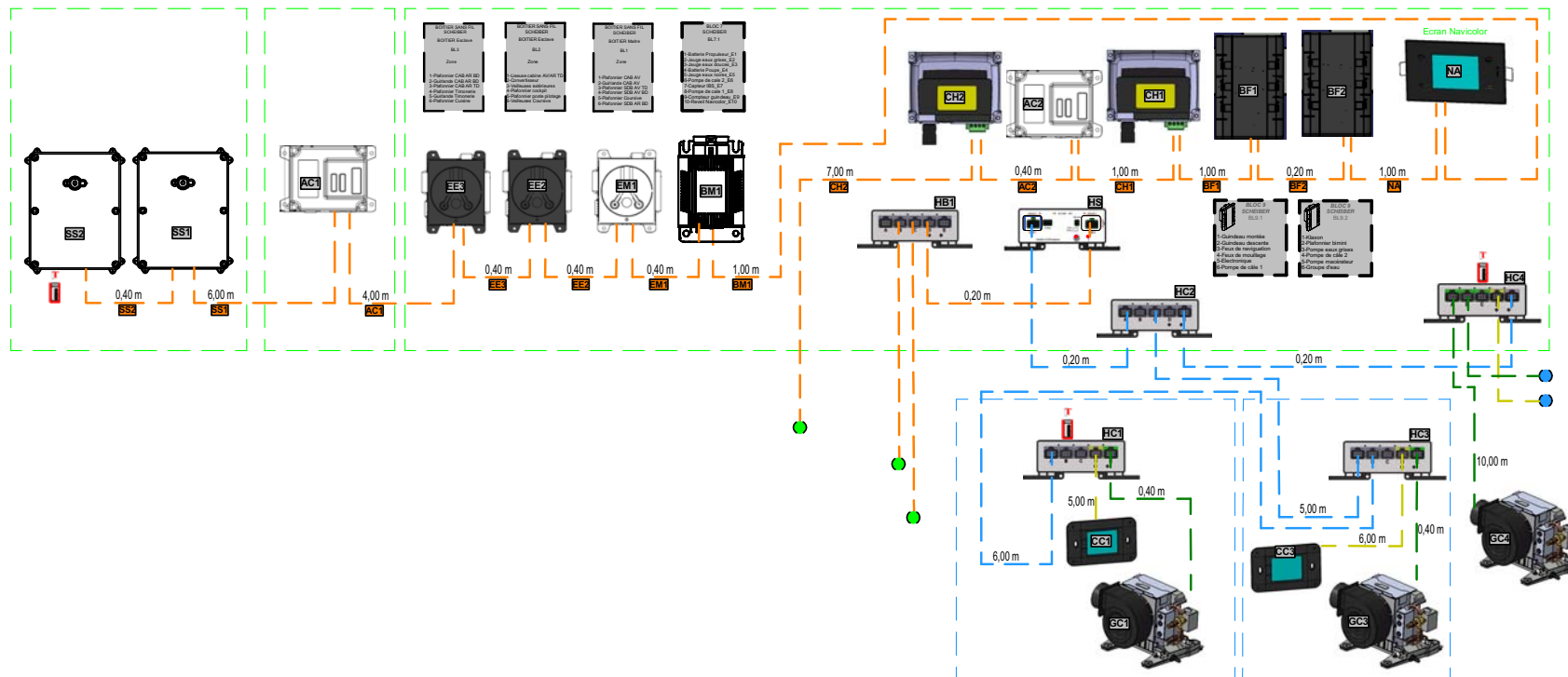

Deck

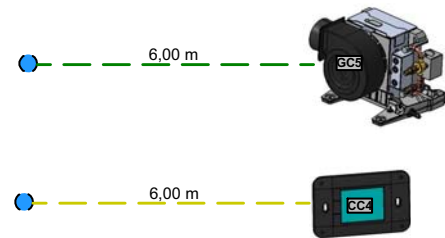
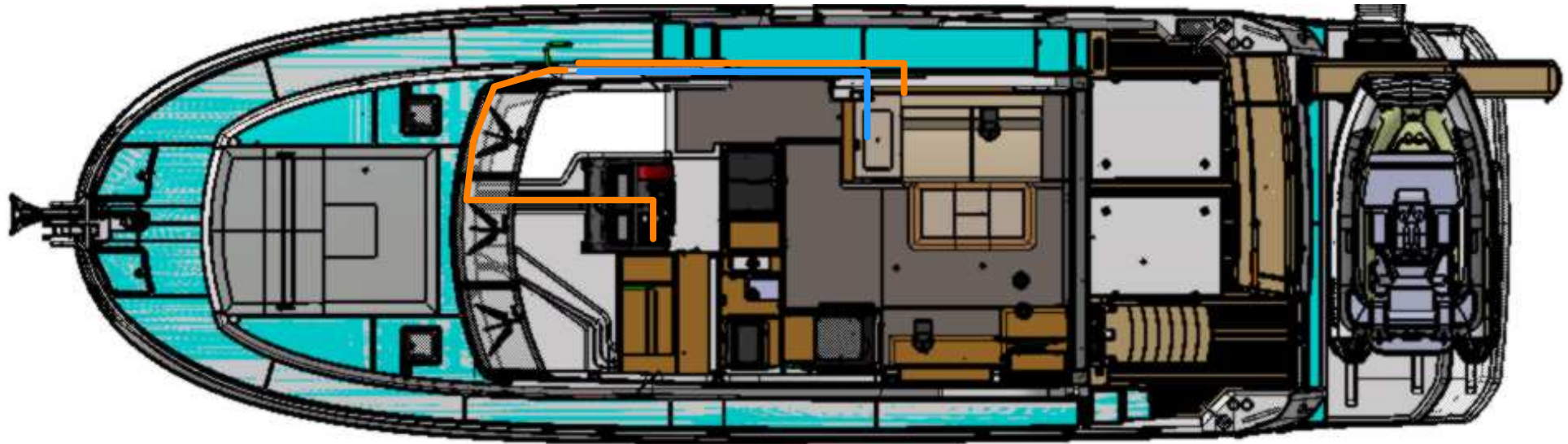

- Liaison CAN BUS Scheiber STD
- Reseau CAN BUS Scheiber STD
- Reseau CAN BUS Scheiber CLIM + ATOLL
- Reseau CAN BUS Scheiber ELECTRONIQUE

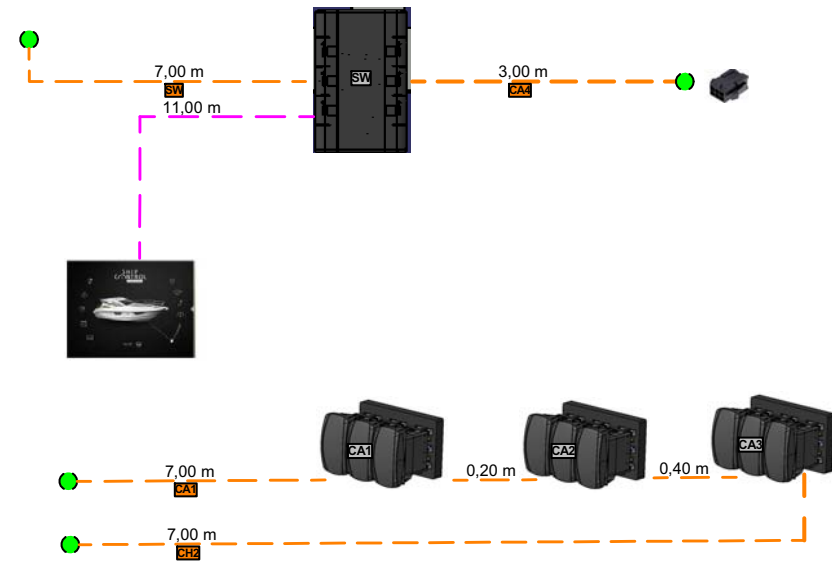

Fly

- Liaison CAN BUS Scheiber STD
- - Reseau CAN BUS Scheiber STD
- - Reseau CAN BUS Scheiber CLIM + ATOLL

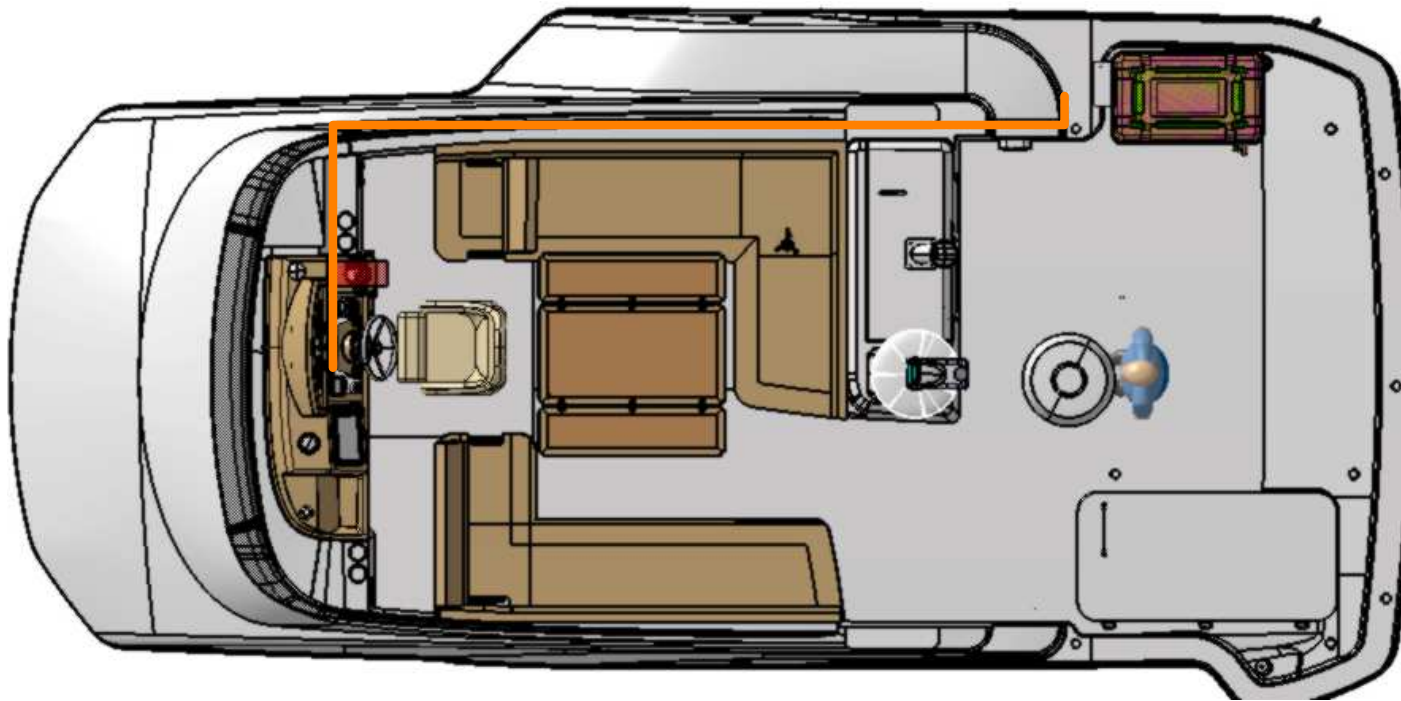

7.4.4 The monozone control



Schema



The monozone control is a touch screen that allows you to control the following in each cabin:



- Lighting,
- Air conditioning.





Brightness adjustment:

Brightness of the screen:   70% ▲

Brightness when the screen is on standby:   40%

Time before screen standby (in minutes):   2' 

Bleep:  

Changing the source:

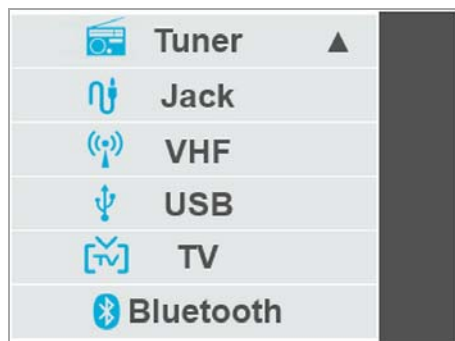

Press the source selection arrow and select the desired source.

Bluetooth connection:

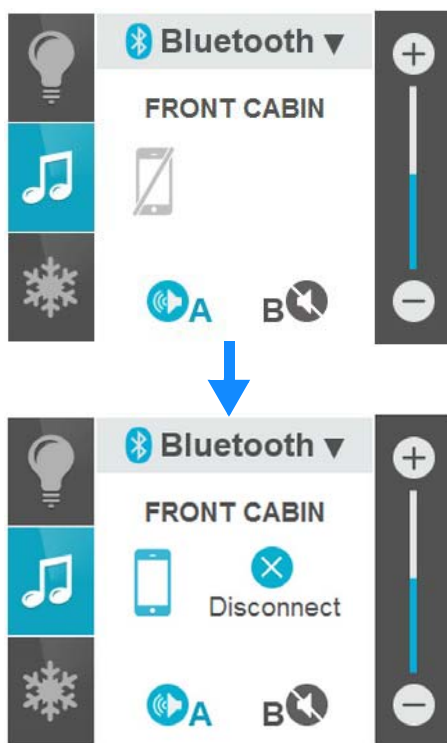

In the Bluetooth tab, this page appears when no device is connected. To connect a device, go to your device's Bluetooth settings and search for the name displayed on the screen (here "FRONT CABIN" is displayed)

Once your device is connected, this page is displayed.

Press the "Disconnect" button in the middle of the screen to disconnect your device from the amplifier.

Storing radio stations:

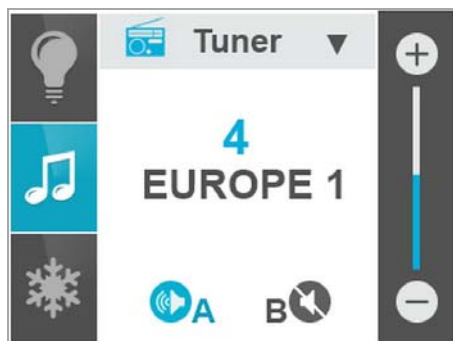

To store radio stations, press the middle of the screen in the "Tuner" tab.



Then, press and hold the desired button to assign the current radio station.

Lighting

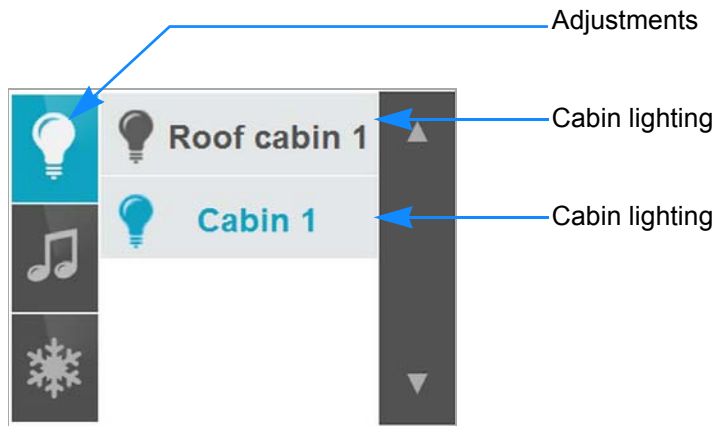

Air conditioning

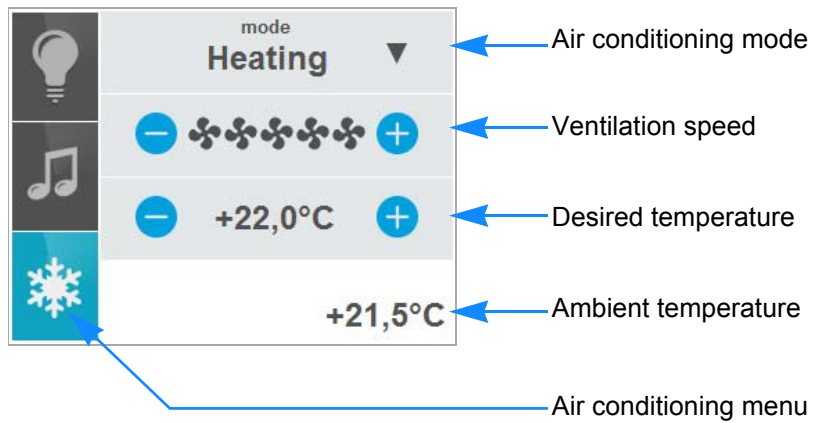

7.4.5 The "block 9s"

Block 9 is the hardware interface of the Ship Control that controls certain functions (bilge pumps, navigation lights, etc.). 3 block 9s are installed in the companionway. If Ship Control fails, Block 9 allows the desired functions to be activated in defect mode. 2 courses of action are possible in defect mode:

- Pressing the keys of the desired component (S1, S2, S3, S4, S5, S6).
- Inserting a by-pass fuse in the support that will activate the associated function. The fuse holder is located under the front of the block 9.

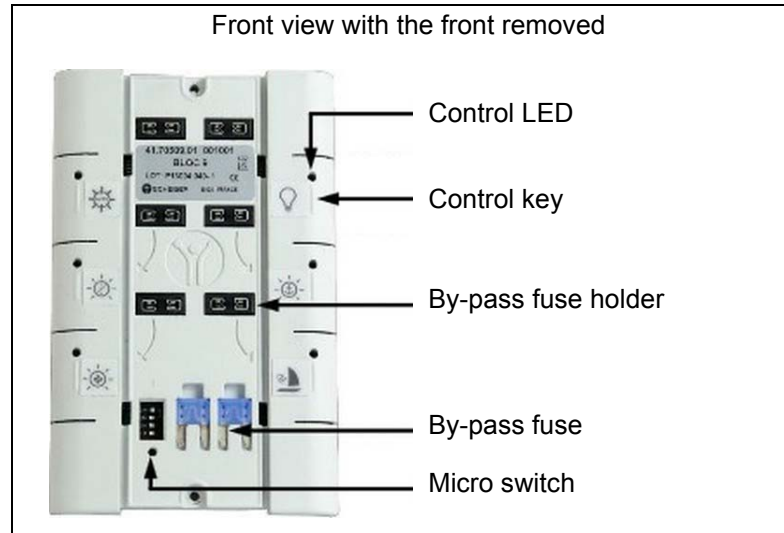
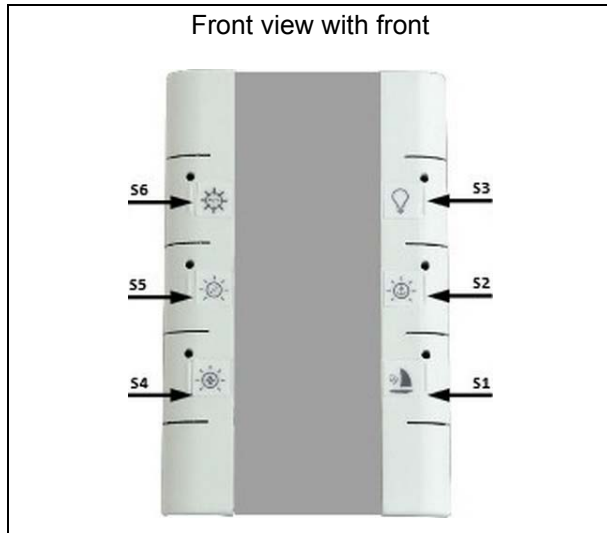

Location: Companionway



1. Block 9 with front
2. Block 9 without front

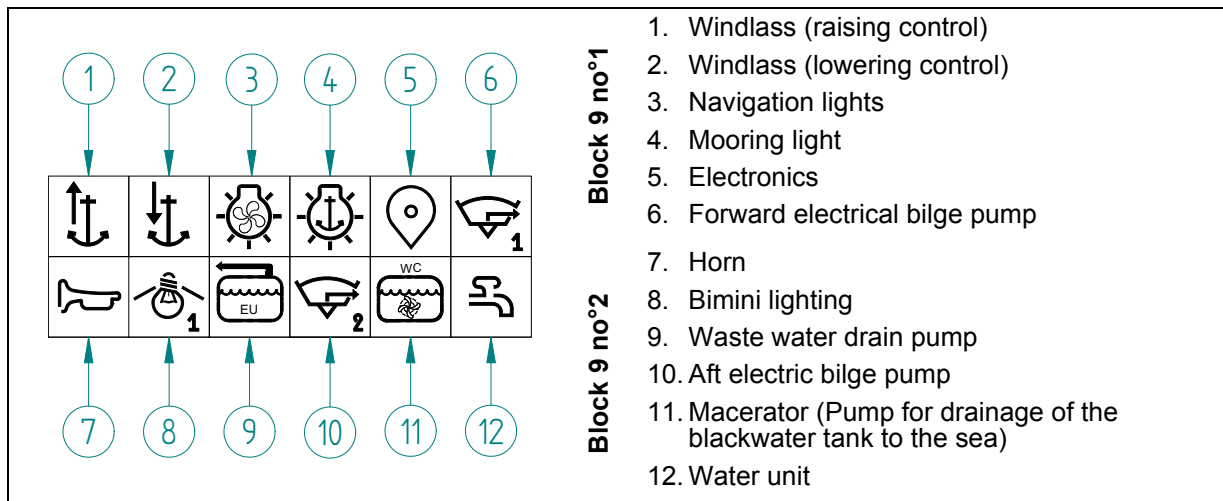

A fuse protects the circuit of each block 9. The fuses are in the electrical cabinet.

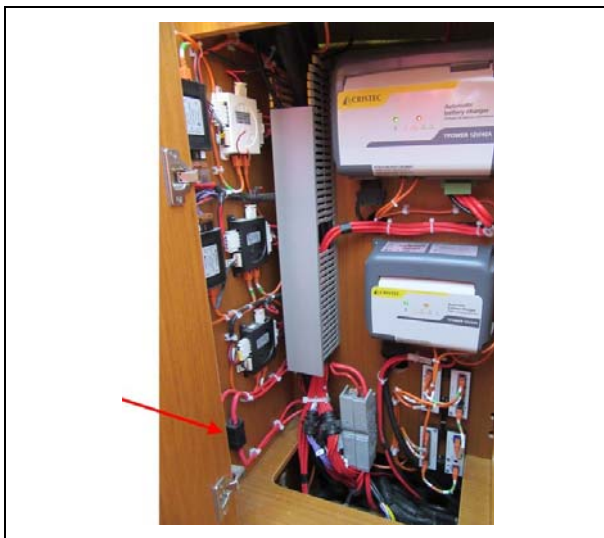

7.5 AC SYSTEM (110V OR 220V)

7.5.1 General points

- The boat is equipped with an alternating current electrical system.
- The electrical system of the boat consists of an AC shore socket and if appropriate:
 - 1 Generator,
 - 1 DC/AC converter.
- The AC electrical system is used to power the following components (where installed):
 - Air conditioning,
 - Household appliances,
 - Water heater,
 - Interior AC sockets,
 - Battery charger(s).

Guidelines for using the AC electrical system correctly

- Do not modify the vessel's electrical installations or the relevant diagrams. Installation, maintenance and modifications must be carried out by an electrician qualified in marine electricity. Have all electrical installations checked (tightening and connections) every year.
- Disconnect the boat's shore power when the system is not in use.
- Connect the relay boxes or metal casings of the installed electrical equipment to the boat's protective conductor (green or green with yellow stripe).
- Use double-insulated or earthed appliances.
- If the reverse polarity indicator is activated, do not use the electrical installation. Rectify the polarity fault before using the vessel's electrical installation (this applies only to polarised circuits with a polarity indicator).

 **If a DC/AC converter is fitted on board: it is essential to switch off the DC and AC circuits before working on the cabin AC sockets.**





- Never let the end of the boat/shore supply cable hang in the water: This may result in an electric field that could injure or kill nearby swimmers.
- Incorrect use of alternating current systems will result in a danger of electrocution.
- Do not work on a live AC system.

 To reduce the risk of electric shock and fire:

- Turn off the shore supply with the onboard cut-off switch before connecting or disconnecting the vessel/shore supply line.
- Connect the boat/shore power cable on the boat before plugging it into the socket onshore.
- Disconnect the boat/shore power cable at the shore socket first.
- If the reverse polarity indicator is activated immediately disconnect the cable.
- After using the socket onshore, close its protective cover tightly.
- Do not modify the connections of the boat/shore power cable: only use compatible connections.

DO NOT MODIFY THE CONNECTIONS OF THE BOAT/SHORE POWER CABLE.

 Electrical connections change over time. It is necessary to have the boat's electrics checked regularly and at least once every two years by a professional. Special attention should be paid to the tightness of the electrical connections.

 Every month, you are advised to test the circuit breaker or residual current differential switch, recognisable by its "test" button.

7.5.2 AC shore socket

Location of components

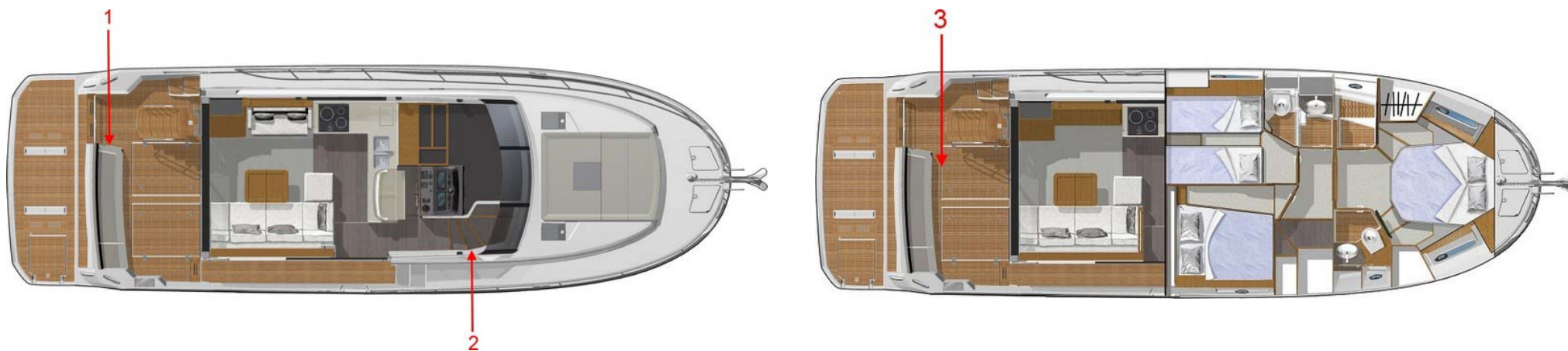

Operation

- First plug the extension cable into the AC socket on the boat, then into the socket onshore.
- First unplug the extension cable from the socket onshore, then from the AC socket on the boat.

Ref 2: Differential switch (Operation)



Ref 3: Bipolar circuit breaker (Protection)



 Refer to the manufacturer's instructions for use and maintenance.

Roller for shore power lead
Location: Cockpit locker



Control



- The winder is unwound manually.
- The winder is wound electrically.

7.5.3 AC source selectors

The shore-generator switch is the actuator for:

- switching between the different AC sources available on the boat. These include the dock socket(s) and the generator.
- measuring the voltage, frequency and current of the power sources connected to it.
- generator start (selector no°1 "onboard") or air conditioning (selector no°2 "air conditioning").
- an isolated measurement (galvanic) of the generator battery.

In the event of system failure, the switch can be operated manually using the handle on the device. Engage the handle, then switch to the right or left of the device to select the desired AC source.

Maintaining switching positions does not require power consumption.

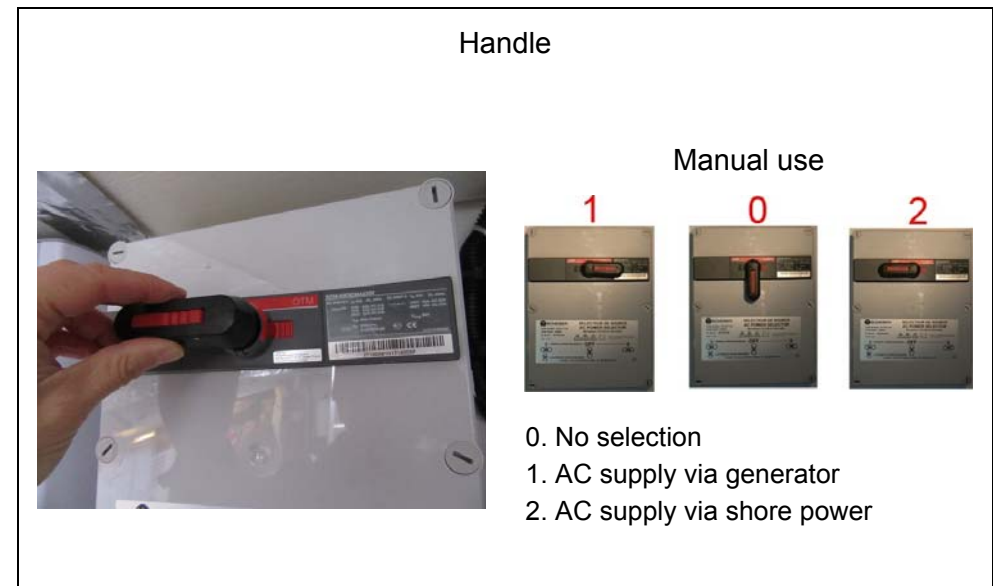
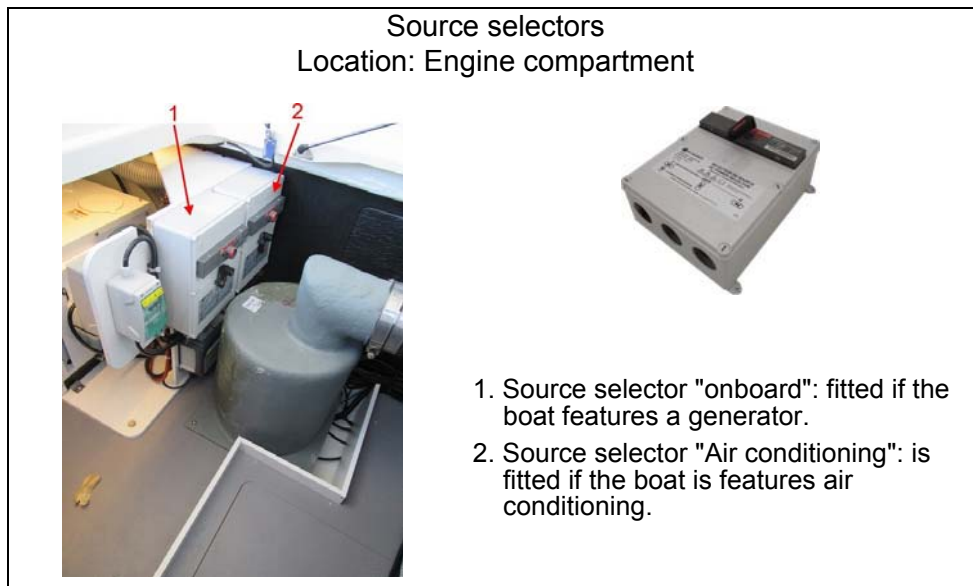

Operation

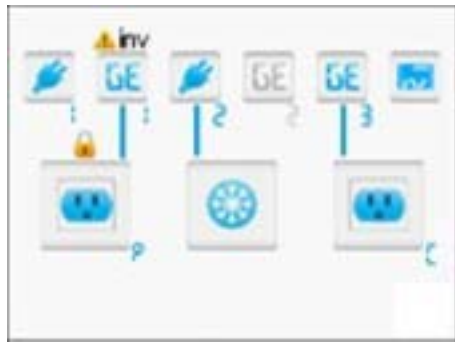
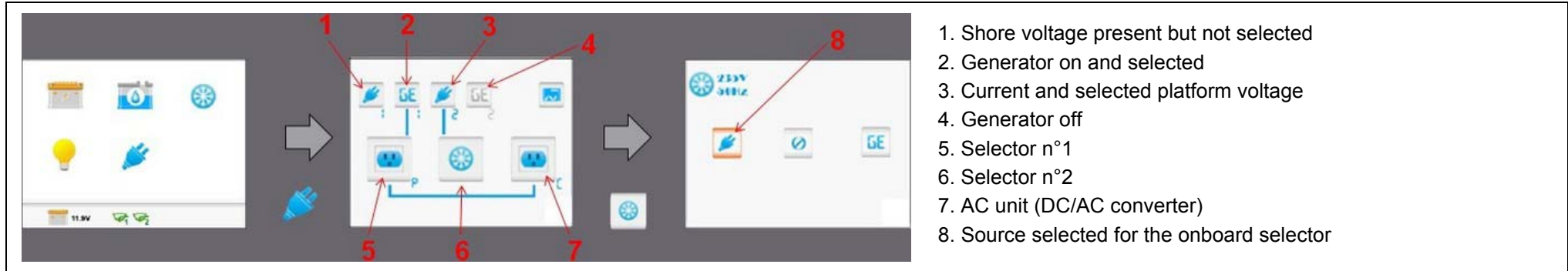

Here, on selector n°1, the padlock indicates the presence of the manual control handle on the selector. Switching cannot be carried out through the screen.

7.5.4 Diagram of layout

AC ELECTRICAL SYSTEM

Europe Version (220V / 50Hz)

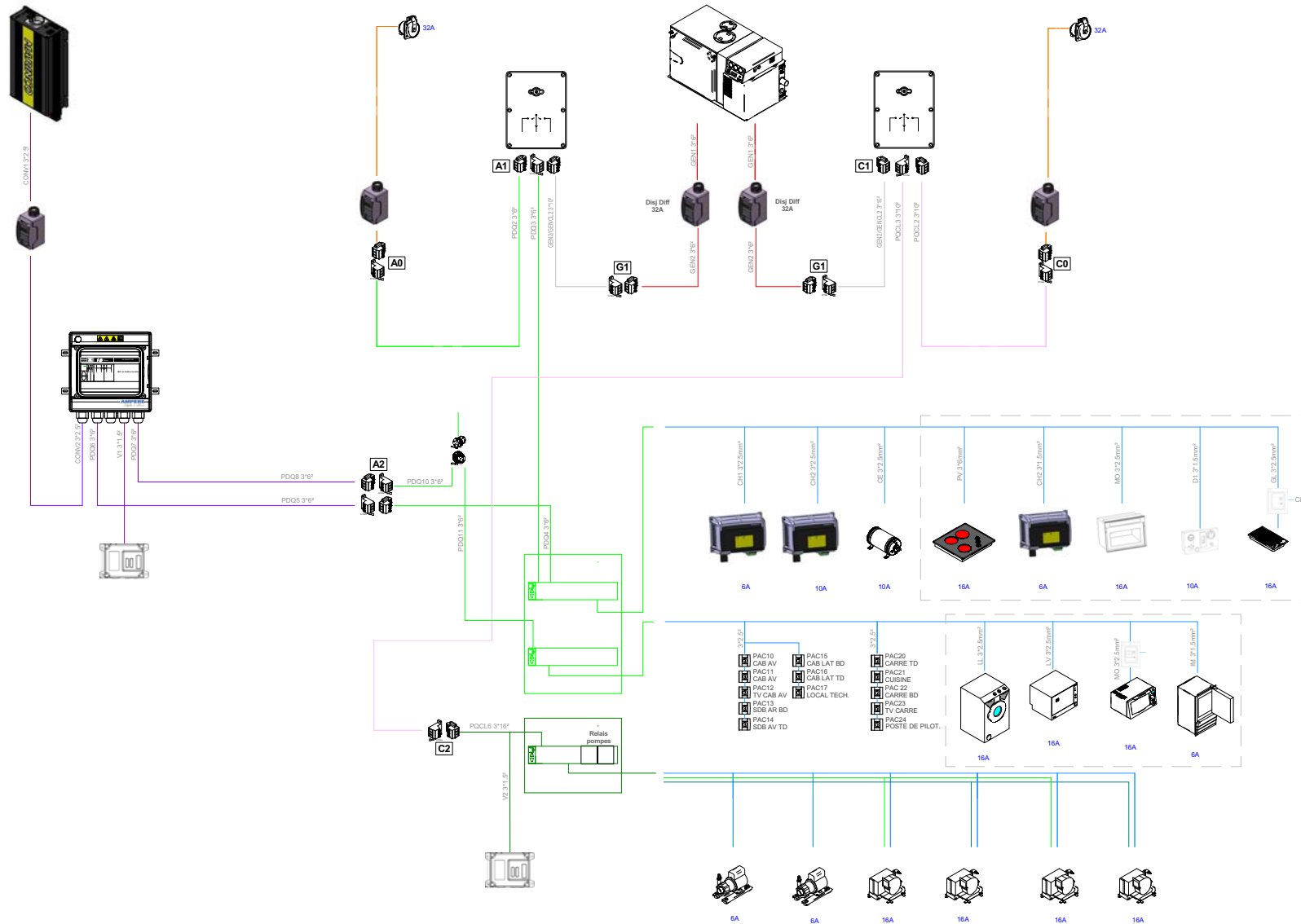

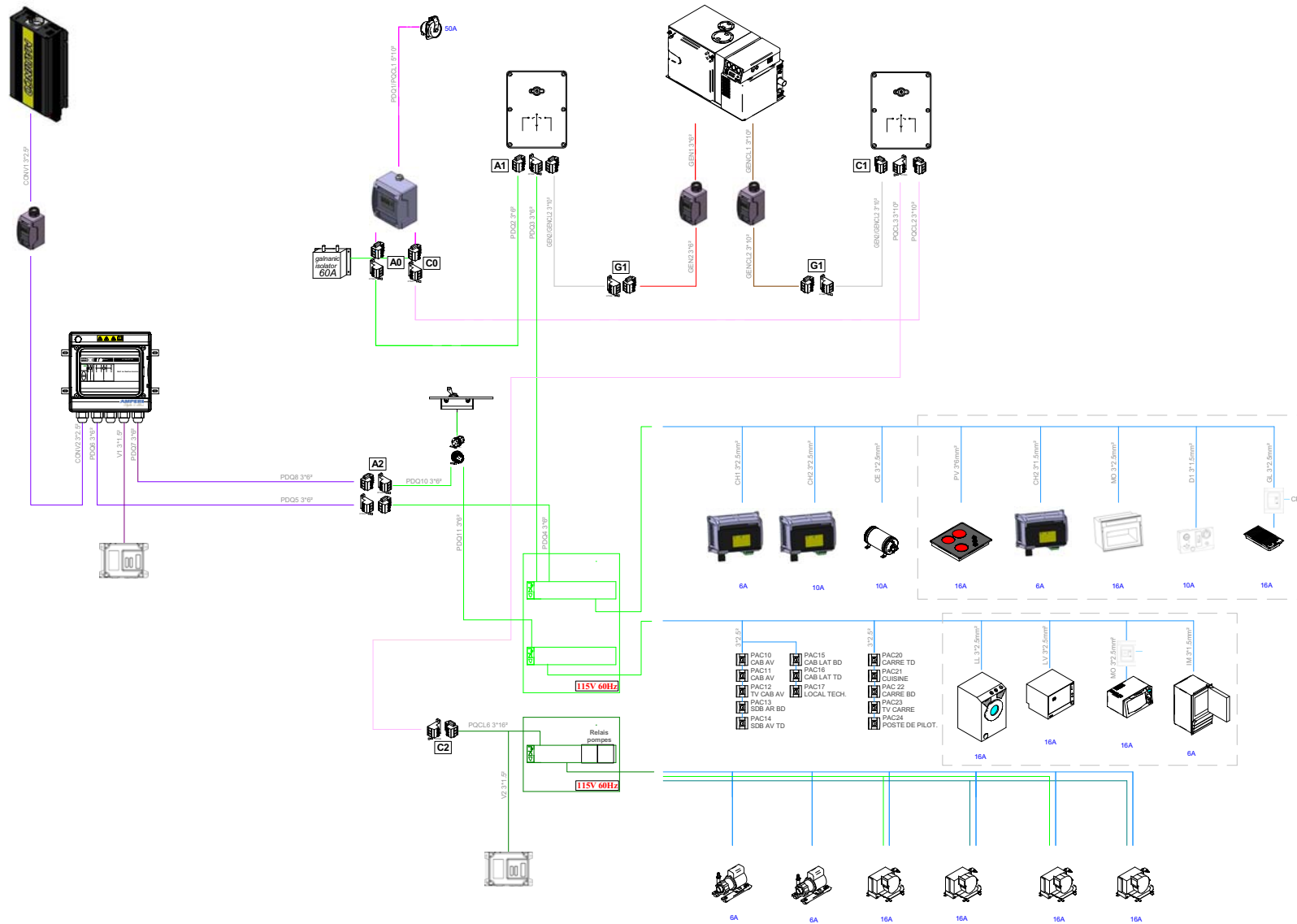

This functions on the principle of isolating the earth of the boat from that of the shore using a galvanic isolator. This assembly protects the motors from electrolysis in the event of faulty insulation between the negative side of the battery and the boat's earth.

Installation of galvanic isolators: Cockpit locker



Indoor socket circuit breaker
Location: Companionway



Brazil Version (220V / 60Hz)

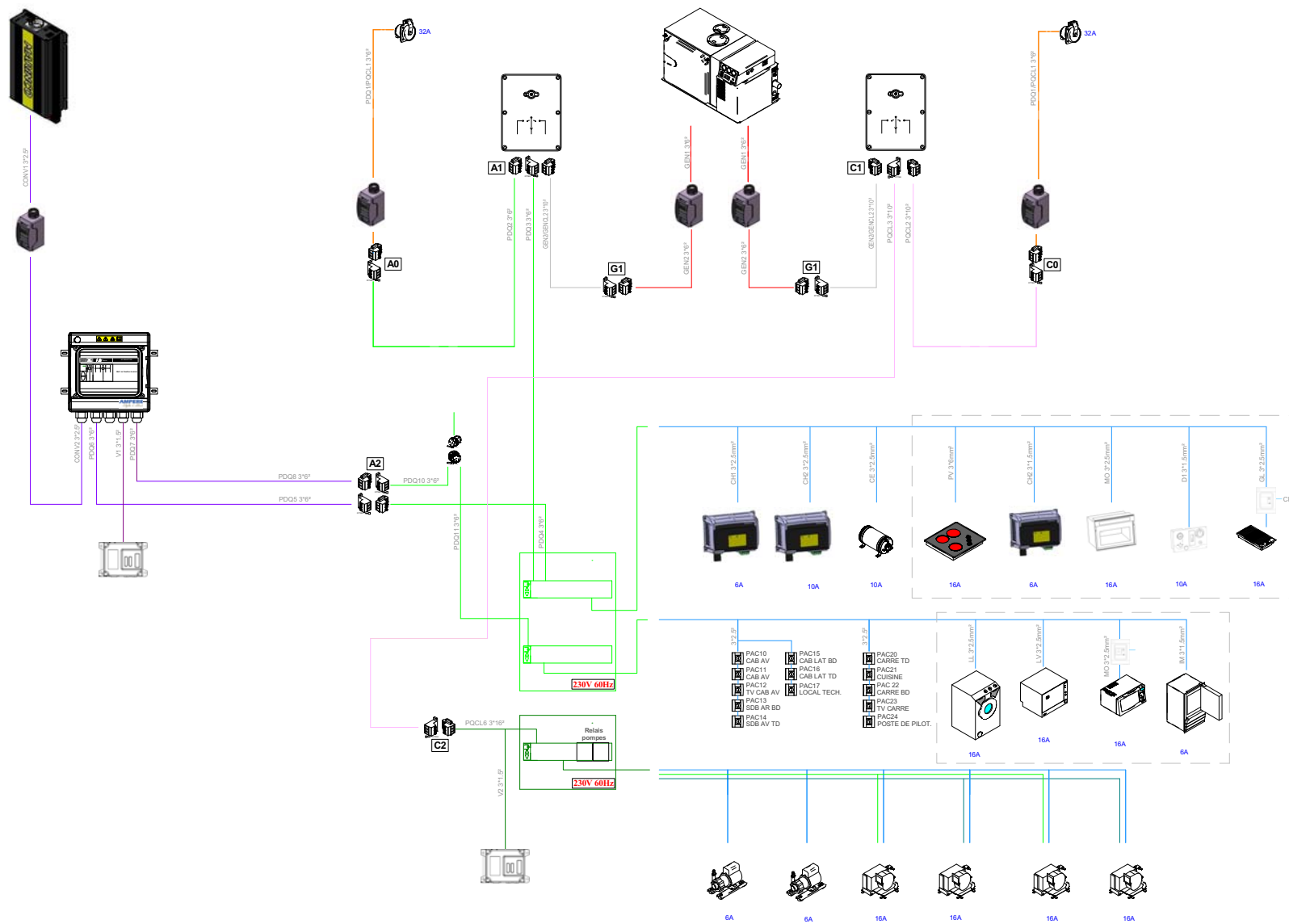

7.5.5 DC/AC converter

Description

- The inverter converts the DC voltage of the service battery bank to AC voltage. The circuit between the inverter and the batteries is protected by a fuse or a circuit-breaker.
- The inverter is earthed by an earthing plate located under the hull (see Chapter: EARTHING PLATES).
- The voltage measurement delivered at the converter output is visible on the touch screen.

Operation

Power supply for the 220V AC electric sockets in the cabins:

Once there is sufficient nominal voltage coming from the AC switch panel, AC power is supplied by the onshore socket or by the generator.

If there is insufficient nominal voltage coming from the AC switch panel, the AC power supply automatically switches over to the inverter. In this way, the power for the 220V sockets in the cabins can be supplied by the inverter, itself supplied by the service battery bank. Be careful to disconnect the inverter circuit to prevent the AC power supply automatically switching over and to prevent accidental discharge of the service battery bank. This can be done by:

- setting the inverter's circuit-breaker to the OFF position; or,
- setting the switch located on the inverter to the OFF position.

The "AC socket" circuit breakers of the AC board are sufficient to isolate the installation sockets.

Operation

- The inverter is fully automatic.
- A remote control is located near the boat's switch panel. To start the converter put the switch on the inverter in the "REMOTE" position then put the switch located on the remote control in the "ON" position.
- The DC/AC converter can also be controlled from Ship Control (see Chapter: SHIP CONTROL).
- If the switch on the inverter is in the "OFF" position, you cannot use the remote control to start it.
- The DC/AC converter operates by default when shore power is not supplied. It is controlled by a relay connected to the shore power supply. This converter powers the indoor sockets and some onboard appliances.
- When shore power is not connected, the relay automatically connects the inverter to a part of the onboard AC circuit.
- When the shore power socket is plugged in and powered, the relay automatically disconnects the inverter.

Maintenance

- Check at least once a year that the inverter cables and connections are securely tightened.
- Clean the inverter by removing any accumulated dust to ensure good ventilation.

Location: Aft cabin



1. AC circuit-breaker
2. DC/AC converter

Remote control



- ! - Refer to the manufacturer's instructions for use and maintenance.
- NEVER:
 - connect the inverter AC lead to an AC terminal or to the onboard generator.
 - disconnect the wiring from the inverter when in use.
 - open the inverter.

7.5.6 AC breakers

Location: Companionway

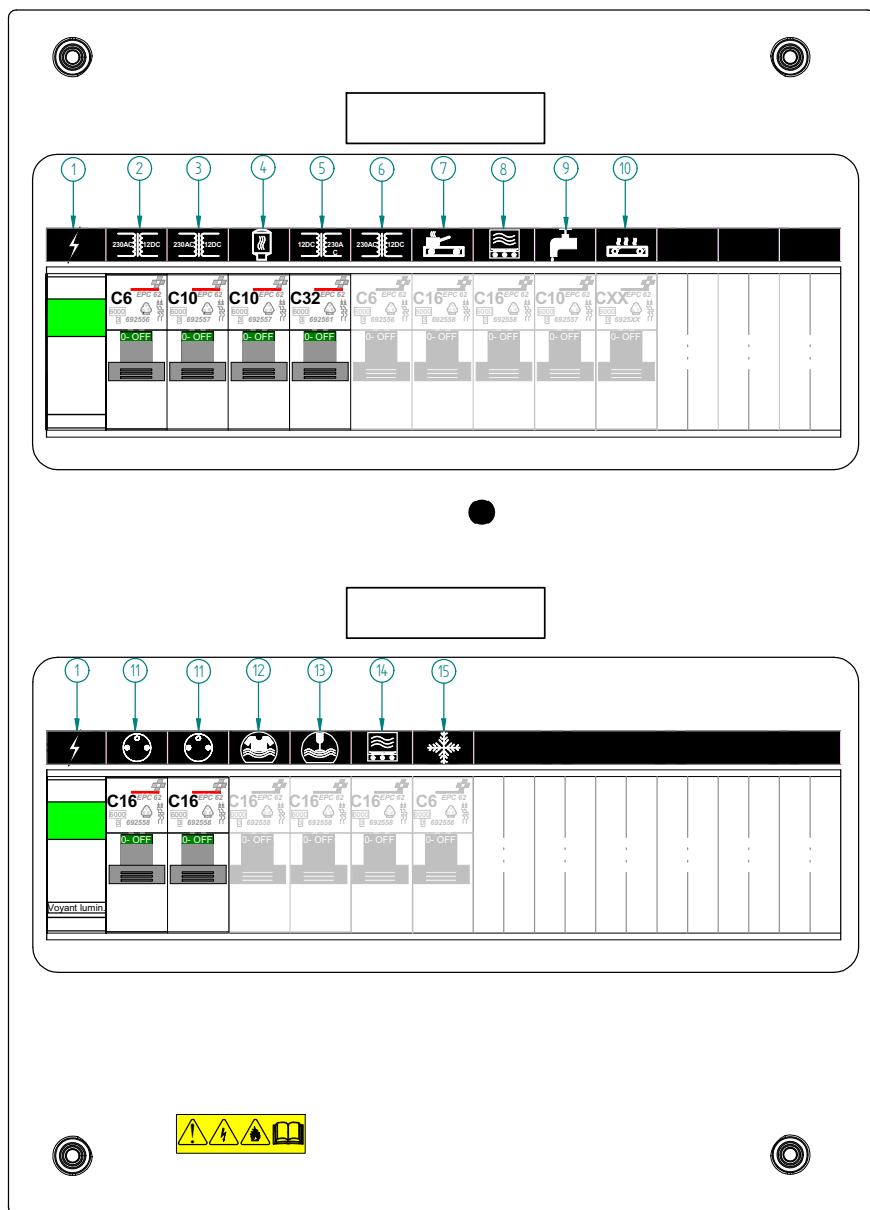

Reference	Designation
1	AC supply
2	Battery charger 1
3	Battery charger 2
4	Water heater
5	DC/AC converter
6	Battery charger (Generator)
7	Hot plate
8	Oven
9	Water unit
10	External grill
11	Interior AC socket
12	Washer
13	Dishwasher
14	Microwave
15	Ice maker

7.5.7 Layout of hull wiring looms - AC circuit

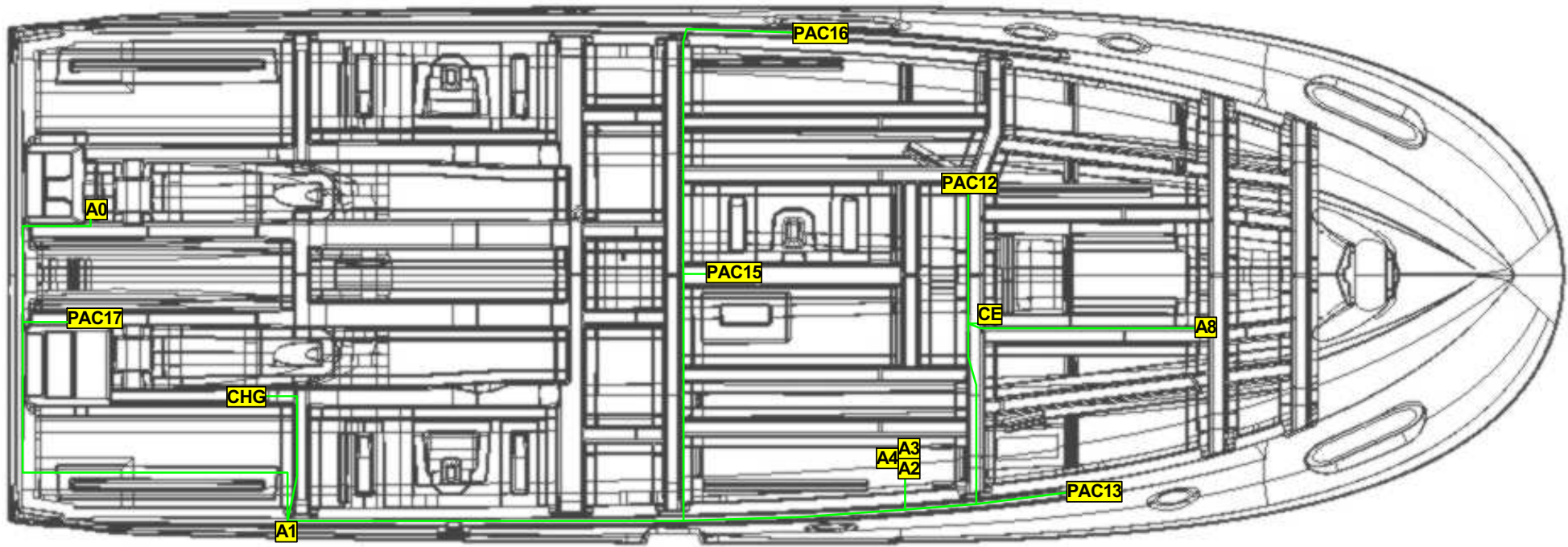

7.5.8 Layout of deck wiring looms - AC circuit

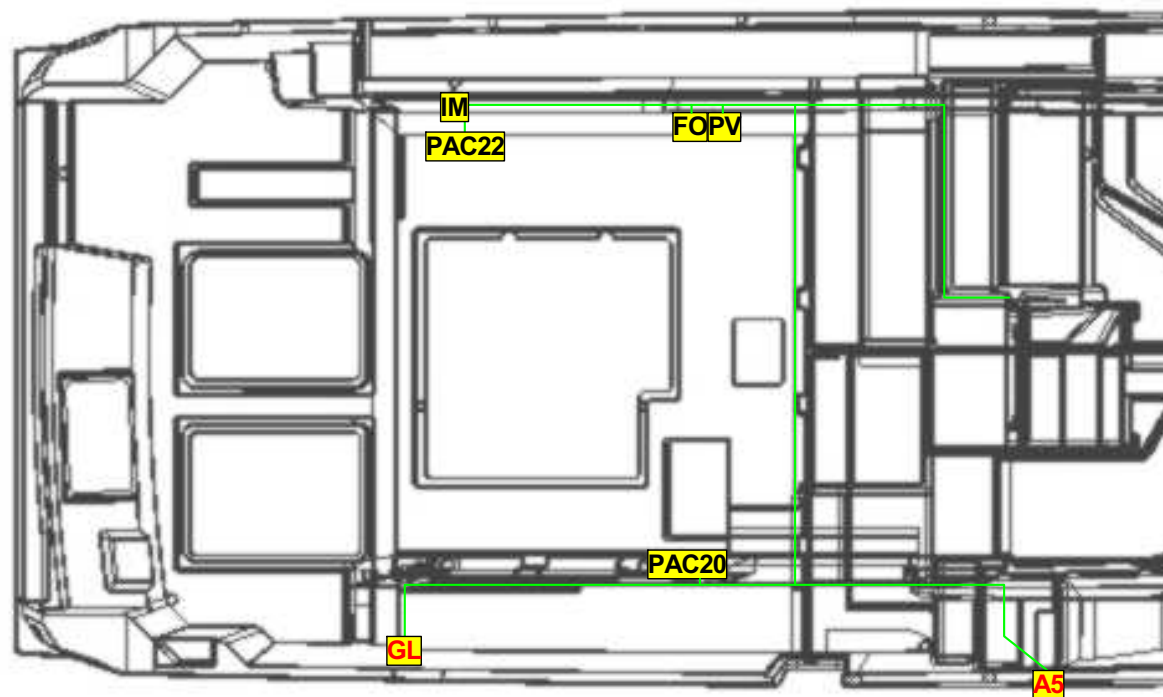

7.6 PROTECTION AGAINST ELECTROLYSIS / EARTH PLATE

7.6.1 Anodes

General points

- The sacrificial anode protects the submerged elements of the boat against electrolysis.
- A sacrificial anode is a consumable part that protects submerged metal parts by its dissolution (oxidation). The anodes used are made of a metal that is more readily reductive than the metal they are protecting.
- On a new boat, all the underwater metallic components seek to reach the same electric potential, which leads to the rapid deterioration of the anodes during the first few weeks in the water.
- You can put several anodes on the hull.

Maintenance

- At least 2 times a year, check the corrosion on all of the anodes. Change the anode if necessary (Before it has lost 50% of its weight).
- Use the appropriate anodes for the cruising area: magnesium anodes for fresh water; zinc anodes for seawater.
- If the motor mountings are raised, the anodes are out of the water: in this case the anodes can no longer protect the sterndrive: take note of the skipper's recommendations.
- When the boat is kept in a dry dock, a light deposit of dust will settle on the anodes: clean the anodes before relaunching.

Cleaning anodes

- Use emery paper. Do not use metal brushes or steel tools to clean the boat as this may damage the galvanic protection.



- Never cover the anodes in antifoul.
- During the first few weeks that the boat is in the water, check the anodes and replace them if necessary: they erode very rapidly during this period.

Replacing the anodes

- The anodes are fastened with screws and nuts. First, remove the screws and nuts that hold the anode, then clean the contact surface. Press the new anode to obtain a good electrical contact.

- Change all the anodes every year.

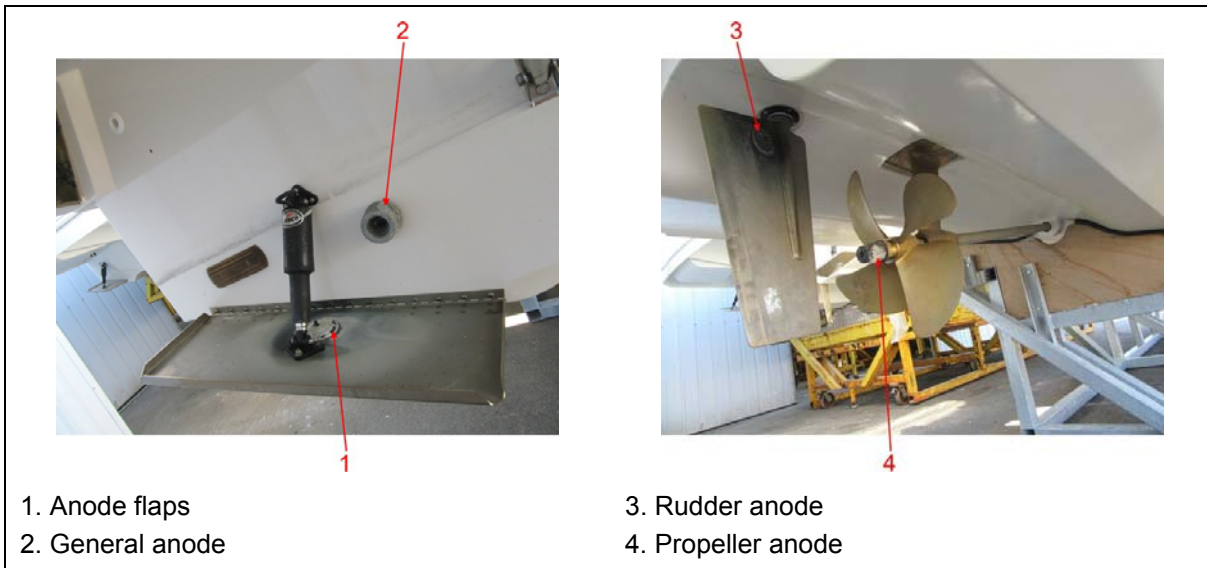

Bow propeller anode



Poop thruster anode



7.6.2 Earthing plates

- An earthing plate is a shot-peened plate mounted on the hull to recreate an earth neutral point on the electrical circuit of the equipment supplying AC power (generator and AC/DC convertor). The earthing plate earths this equipment.

The earthing plate is not an anode: it must not be allowed to deteriorate.

- If the earthing plate deteriorates, consult a professional immediately to determine the cause. Because it is mounted across the hull below the waterline, deterioration of the earthing plate puts the boat at risk of sinking.

 Never antifoul over the earthing plates.

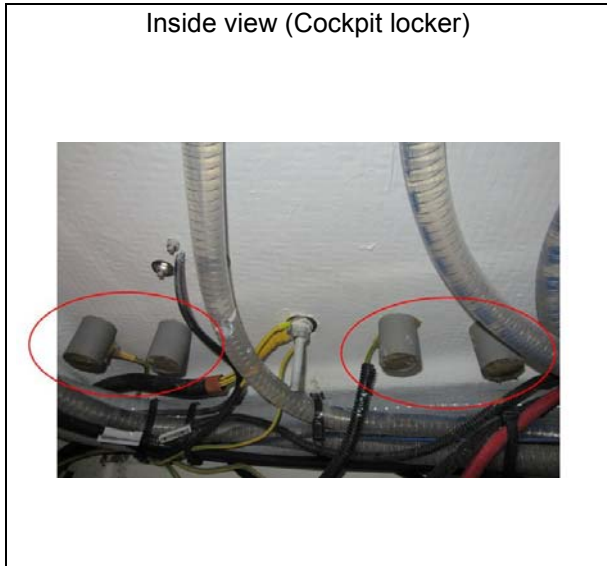
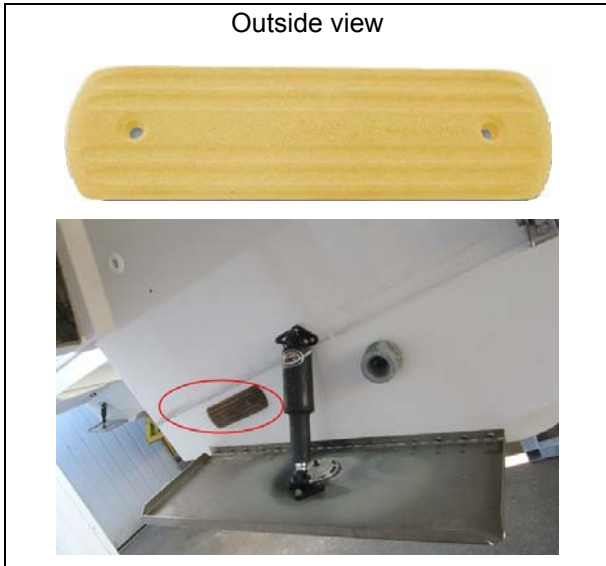

LIQUEFIED PETROLEUM GAS (LPG) SYSTEM

■ General points	130
■ Operation of the LPG system	132
■ Verification of the LPG system	133
■ Diagram of layout	135

8.1 GENERAL POINTS

- The working pressure of the LPG unit is 28 millibars.
- Recommended cylinder capacity:
 - Europe Version: 10 kg of butane.
 - US Version: 5 lb of propane.
- Have the hoses, the entire LPG system and the flue pipes in the LPG system inspected professionally and regularly (or at intervals determined by the national requirements of the country in which the boat sails), and have them replaced if damage is detected.
- Taps attached to empty cylinders must be closed and disconnected. Protective covers, lids or caps must be held in place. Spare bottles must be stored outside on the boat and protected from weather and mechanical damage. If a gas leak occurs, it is essential that the gas escapes outside.
- Do not impede access to the components of the LPG system.
- Do not use the housings or the LPG bottle lockers to store other equipment.
- Check the vent pipes at least once a year. Replace them if they have deteriorated or split.

Location of components

Europe Version

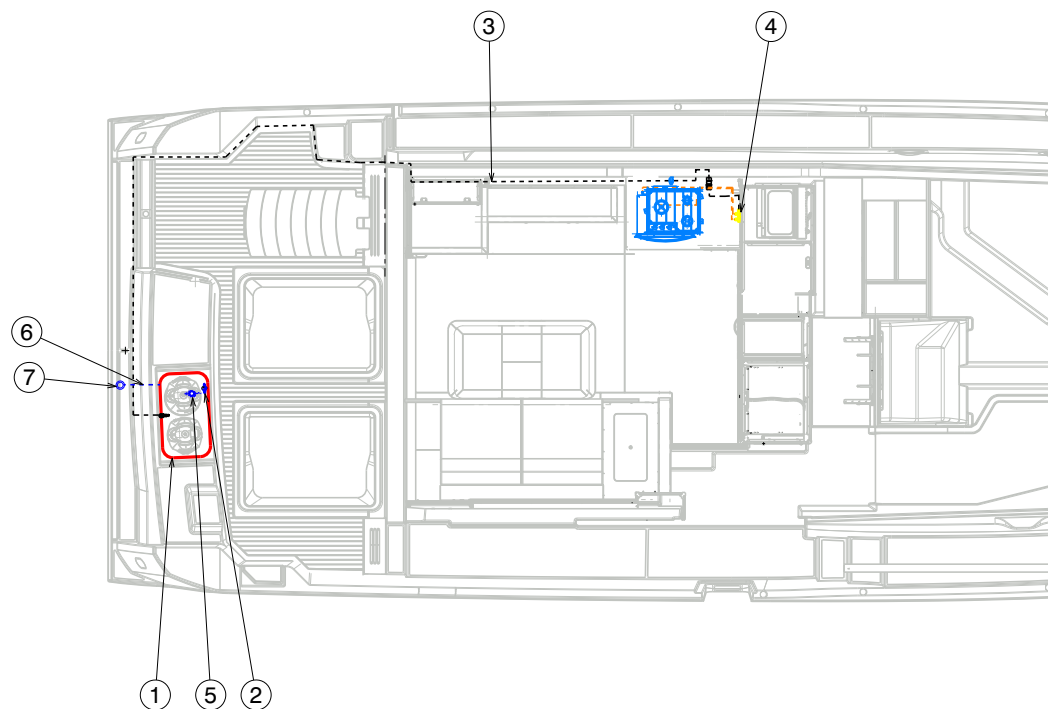

Reference	Designation
1	Gas cylinder locker
2	Bubble tester
3	Gas system
4	Gas supply valve
5	Regulator valve
6	Gas locker drain
7	Kitchen sink thru-hull drainage

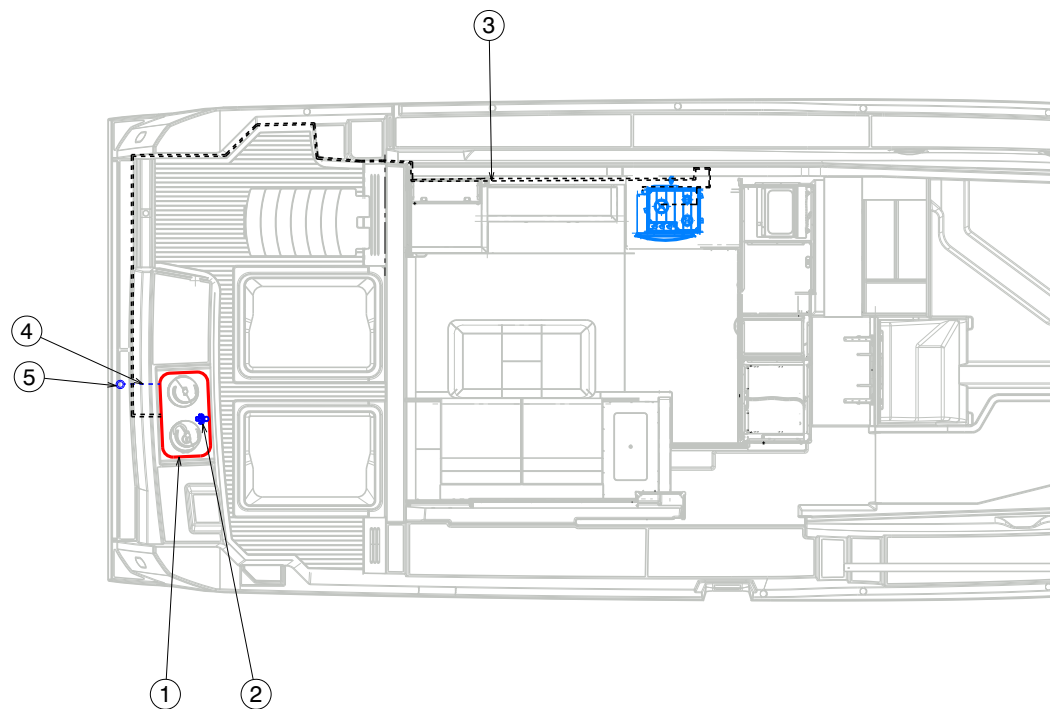

Reference	Designation
1	Gas cylinder locker
2	Regulator valve
3	Gas system
4	Gas locker drain
5	Kitchen sink thru-hull drainage

8.2 OPERATION OF THE LPG SYSTEM

- Valves for supply lines and cylinder valves must be closed when appliances are not in use, before changing a cylinder and immediately in case of emergency.
- Appliance valves must be closed before opening the cylinder valve.
- Ventilation is necessary when appliances that consume oxygen from inside the boat are used.
- If the stove is not suspended by gimbals, it should not be used when wide roll angles or continuous listing are likely.
- Please refer to the manufacturer's notes for the use and maintenance of the LPG cooker.

8.3 VERIFICATION OF THE LPG SYSTEM

The LP system should be tested for leakage before each use in any of the following ways:

- If the LPG circuit is equipped with a pressure gauge:

Before each use, close the appliance valve, open the LPG cylinder valve, allow the pressure gauge to stabilize, close the LPG cylinder valve and observe the pressure indicated by the pressure gauge near the LPG cylinder for 3 minutes. The pressure indicated by the manometer should be constant if there is no leak in the system.

The pressure indicated by the manometer should be constant if there is no leak in the system. If bubbles are observed in the detector liquid, there is a leak.

NOTE: The pressure gauge only indicates vapour pressure, which is a constant at a given temperature. It gives no indication of the amount of LPG remaining in the cylinder..

- If the LPG circuit is equipped with a bubble leak detector, use it as follows:

Regularly observe the bubble leak detector.

OR

Once the installation is pressurised and stabilised, press the detector push button. The installation is not leaking if bubbles do not appear in the detector liquid. If bubbles are observed in the detector liquid, there is a leak.

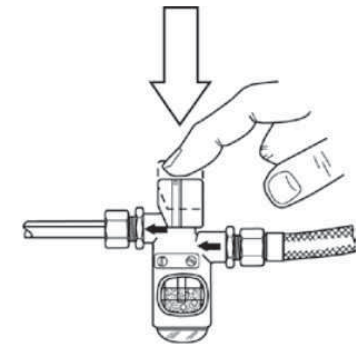

- Carry out a manual search by applying a foaming solution, soapy water or a detergent (with the burner taps closed and the installation and gas bottle taps left open). Foaming solutions for detecting leaks in gas installations conforming to EN 14291 are adequate for these requirements.

- If an LPG leak is detected or suspected, immediately take the following measures:

- Cease use of all LPG appliances;
- Disconnect the LPG supply from the supply valve(s);
- Extinguish all naked flames and other sources of ignition (heaters, cooking appliances, pilot lights, etc.);
- Do not operate electrical switches;
- Evacuate the area if possible.

NOTE: Leak tests carried out by the boat user are not a substitute for regular and complete checks of the LPG circuit by a competent professional.

To change an LPG bottle

1. Close the tap on the LPG bottle
2. Detach the LPG bottle
3. Replace the LPG bottle
4. Attach the new LPG bottle
5. Open the tap on the LPG bottle

Hob / Oven



Gas cylinder locker



Gas supply valve

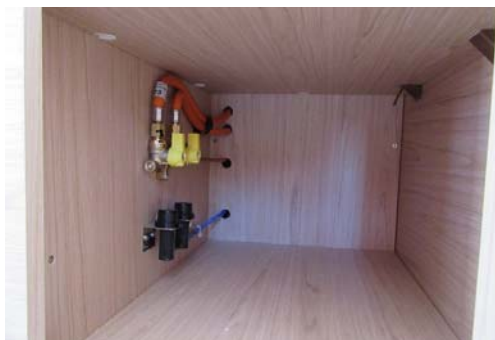

- When the cooker is on, ventilate well to prevent any risk of asphyxiation.
- Do not use the cooker as a means of heating.



- If a leak or fire from an LPG tank is detected, close the main LPG supply valve and do not use LPG appliances.
- Do not use an installation with a leak before it has been inspected and repaired by a competent person.
- Do not modify the boat's LPG system. Installation, modification and maintenance should be carried out by a qualified individual. Have the system checked at regular intervals or as prescribed by national requirements.
- Never use a naked flame to check for leaks.
- Do not use a hotplate or an oven to heat the living areas.
- Fuel-burning equipment with a naked flame consumes the oxygen in the cabin and leaves combustion residue in the boat. Ventilation is necessary when this equipment is used. Open the vents provided for this purpose when using this equipment. Do not use a hotplate or an oven to heat the living areas. Never obstruct the openings provided for ventilation.
- Ventilation requirements have been calculated for LPG appliances as installed. Additional ventilation openings may be required if other appliances are installed in addition to these (please consult a professional).
- Never leave the boat unsupervised when equipment using LPG with a naked flame is on.
- Do not smoke or use a naked flame when replacing LPG bottles. Close the tap on the empty bottle before detaching to replace it.
- To ensure sufficient ventilation, make sure that you open the hatches or ports near the hotplate when using it.



- Do not use solutions containing ammonia when testing for leaks manually (ammonia, which is present in certain soaps and detergents, attacks brass connections). Although the damage may at first be impossible to detect, the cracks and leaks may appear several months after contact with the ammonia).

8.4 DIAGRAM OF LAYOUT

Europe Version

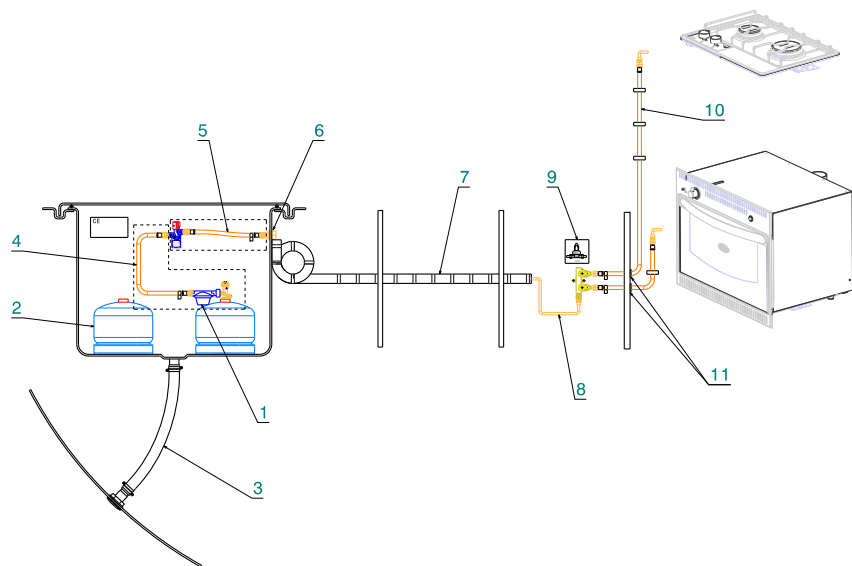

Reference	Designation
1	Regulator valve
2	Gas cylinder
3	Drain
4	Gas bottle connection kit
5	Bubble tester kit
6	Rubber washers
7	Ringed PVC sheath
8	Copper gas connection kit
9	Label
10	Gas appliance connection kit
11	Bulkhead fitting

US Version

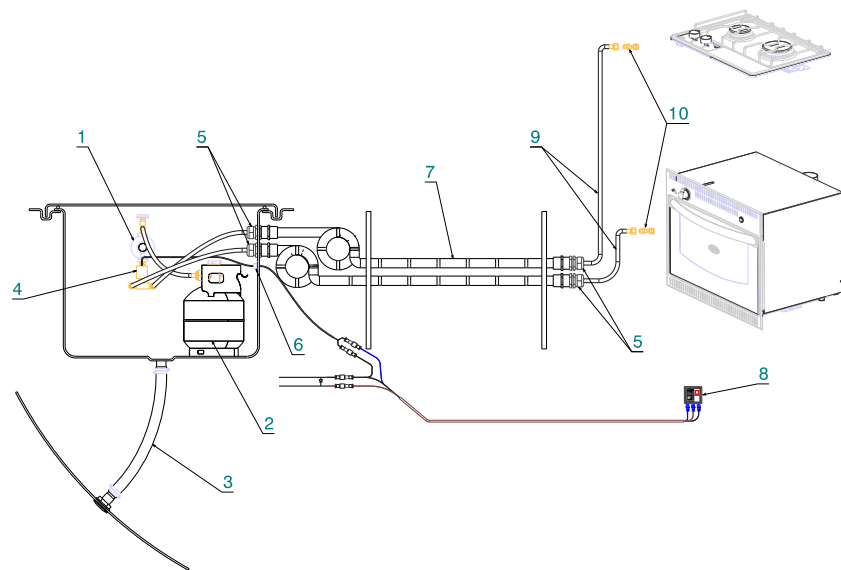

Reference	Designation
1	Regulator valve
2	Gas cylinder
3	Drain
4	Electromagnetic valve (12V)
5	Bulkhead fitting
6	Wire passage
7	Ringed PVC sheath
8	Solenoid switch
9	Plastic propane pipe
10	Gas appliance connection kit

DOMESTIC APPLIANCES

■ Fridge.....	138
■ Microwave	140
■ Hot plate	141
■ Oven / microwave combined unit	141
■ Washer / Dryer	142
■ Dishwasher	143
■ External grill.....	144

9.1 FRIDGE

General points

- The fridge comprises 3 components: the compressor, the evaporator and the condenser. These components are connected by a closed refrigerant gas circuit. The fridge is air-cooled.
- The fridge is DC powered. It is designed to chill food and drink. Any other use is dangerous and must be strictly avoided.
- A breaker protects the electrical circuit.
- The ON/OFF start button is located on the fridge.
- The thermostat is in the inside compartment of the fridge. It enables selection of the desired temperature setting for the inside of the fridge.
- The refrigeration power can be affected by:
 - The ambient temperature,
 - The quantity of food to chill,
 - The frequency with which the door is opened.

Maintenance

- Clean the evaporator with a damp cloth at least once a year. Never use cleaners which are abrasive or acidic, or which contain solvents, for cleaning the evaporator.
- Regularly clean the fridge door joint with a damp cloth.
- Regularly defrost the fridge.
- When winterising the boat, leave the fridge door/icebox cover open to prevent mould and odours from developing.



- Refer to the manufacturer's instructions for use and maintenance.
- Never heat or use tools to defrost the inside of the fridge more quickly (doing so may damage the interior surface).
- Never obstruct the heat exchanger of the fridge.

Fridge (Flying bridge)



NOTE: The control is located directly inside the device.

Fridge (Galley)



NOTE: The control is located directly inside the device.

Additional fridge
Location: Saloon



NOTE: The control is located directly inside the device.

9.2 MICROWAVE

General points

- The microwave is AC powered.
- A breaker protects the electrical circuit.
- The microwave is designed to reheat food and drink or to cook food. Any other use is dangerous and must be strictly avoided.
- The microwave must never be started when empty.
- Remove all foil or metallic packaging elements before putting food in the microwave.
- Remove airtight coverings from packaging before putting food in the microwave.

Starting up

- Completely remove the microwave from its storage (a safety device will prevent the microwave from being supplied electrically if it is not completely out).
- Use the switch to select the desired power source (shore power or generator).
- Put the microwave circuit-breaker in the ON position.

Maintenance

- Regularly check the door seals.
- Regularly clean the inside of the fridge with a damp sponge.

Up/down switch



Location: Galley



9.3 HOT PLATE

General points

- The hob runs on an AC power supply.
- A breaker protects the electrical circuit.

Starting up

- Use the switch to select the desired power source (shore power or generator).
- Turn the hob circuit breaker to ON.

9.4 OVEN / MICROWAVE COMBINED UNIT

General points

- The oven is powered by alternating current.
- A breaker protects the electrical circuit.

Starting up

- Use the switch to select the desired power source (shore power or generator).
- Turn the hob circuit breaker to ON.

Location: Galley



9.5 WASHER / DRYER

General points

- The washing machine runs on an AC power supply.
- A breaker protects the electrical circuit.
- The washing machine is supplied with water from the onboard tanks via a supply valve.
- The waste water is emptied into the grey water tank.

Starting up

- Check the level in the water tanks and switch on the water system.
- Open the water supply valve/washing machine.
- Turn on the AC circuit (shore or generator) and actuate the washing machine circuit breaker.
- Start the washing machine.

 Never allow children to use the domestic electrical equipment unsupervised.

 Refer to the manufacturer's instructions for use and maintenance.

Location: Companionway



Washer-dryer supply valve
Location: Starboard headroom



US Version: hot/cold water
Europe Version: cold water only

9.6 DISHWASHER

General points

- The dishwasher is AC powered.
- A breaker protects the electrical circuit.
- The dishwasher takes the water from the tanks onboard via a water feed valve.
- The waste water is emptied into the grey water tank.

Starting up

- Check the level in the water tanks and switch on the water system.
- Open the valve of the water supply onboard / dishwasher.
- Turn on the AC power (shore or generator) and actuate the dishwasher's circuit-breaker.
- Turn on the dishwasher.



- Refer to the manufacturer's instructions for use and maintenance.
- Do not operate the washing machine/ dishwasher when at sea.

9.7 EXTERNAL GRILL

- The grill runs on an AC power supply.
- A safety cut-off switch is mounted on the lid: shutting the lid turns the grill off automatically and immediately.
- A breaker protects the electrical circuit.

Location: Flying bridge



Before using the grill, it is advisable to add a little water to the retaining tray so that hot fat will cool quicker.

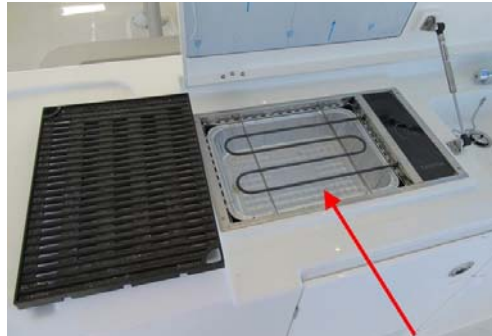

- Anyone using the grill must be wearing shoes and dry clothes. A person who has become wet (e.g. from swimming) must dry his or herself off completely before using the grill.



- Refer to the manufacturer's instructions for use and maintenance.
- Using the grill while under way must be strictly avoided.
- Check the temperature of the grill before reclosing the cover.

AUDIO-VISUAL EQUIPMENT

■ Television	146
■ HiFi	147
■ Diagram of layout	148

10.1 TELEVISION

- Power for the television is supplied by alternating current. Depending on the equipment of the boat, alternating current may be provided by:
 - the AC shore power socket,
 - the generator,
 - the DC/AC converter powered by service batteries.
- A circuit-breaker protects the circuit.
- Pre-cabling for the aerial is already installed on the boat.

Starting up

- First turn on the circuit breaker, then switch on the TV.

10.2 HIFI

- The sound system is DC powered.
- The HIFI is controlled from Ship Control (see chapter: SHIP CONTROL) or directly from the car radio.
- The sound from the TV comes out of the integral speakers.
- The sound from the TV can come from the speakers if ARC is selected on the DVD player.
- The sound from the DVD player comes from the speakers.
- The sound from the radio comes from the inside and outside speakers. It is possible to select either inside or outside speakers by adjusting the balance control.

Location: Forward cabin



Location: Wheelhouse



Refer to the manufacturer's instructions for use and maintenance.

10.3 DIAGRAM OF LAYOUT

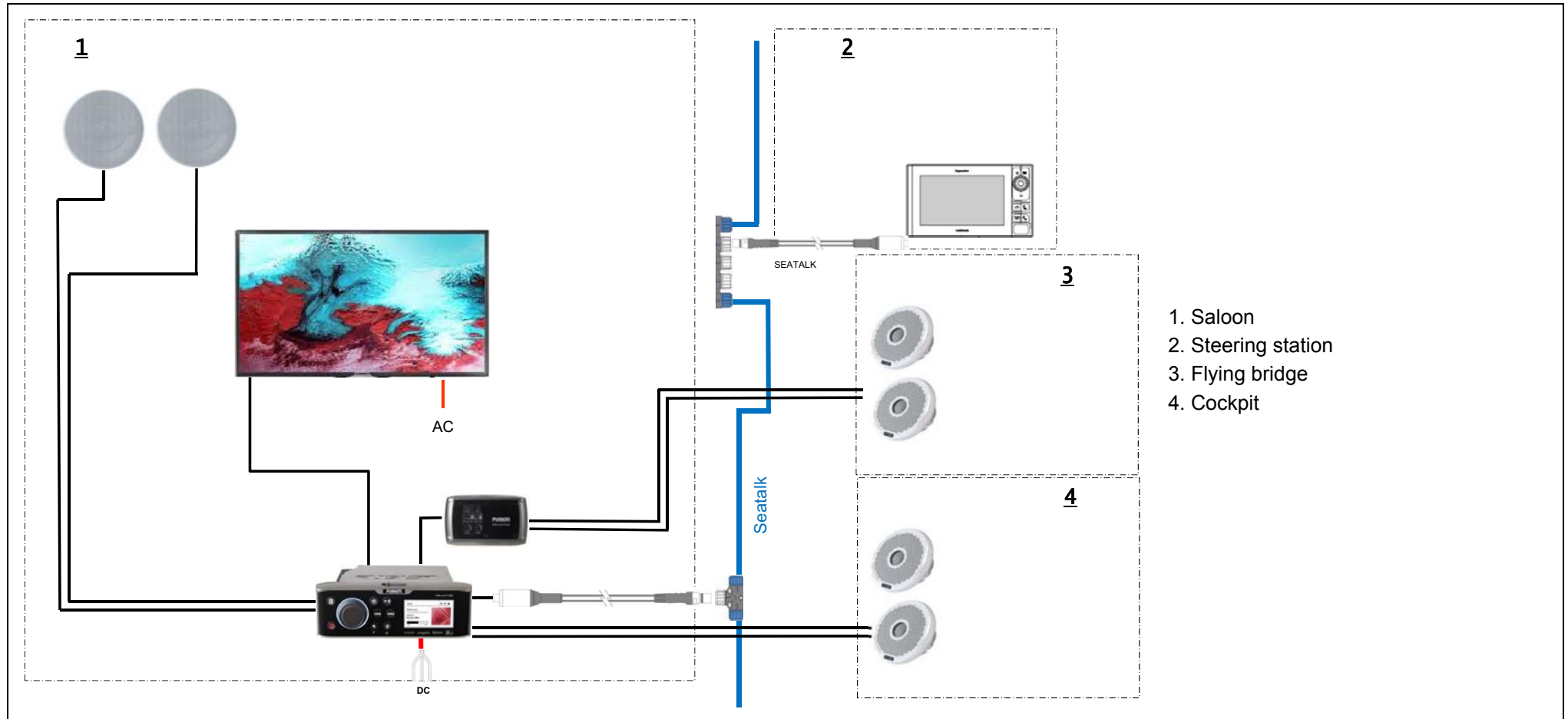

ONBOARD COMFORT

■ Air conditioning	150
■ Electronic equipment	154
■ Fuel-burning equipment for purposes other than propulsion (Generator, Heating)	159

11.1 AIR CONDITIONING

General points

- The air-conditioning is powered by alternating current.
- The air-conditioning cools the air temperature inside the boat (only when the boat is floating in water).
- The cooling circuit consists of one or more compressors that operate independently. A compressor is called "reversible" because it can heat the boat if the seawater temperature exceeds 13°C.
- In winter, you can programme the dehumidifier function on the air conditioning controls.
- The refrigeration compressors are made by one or two seawater pumps. These pumps are run on AC voltage and are master controlled by one or two relay boxes.
- Seawater is drained via a through-hull fitting equipped with a valve, located above the waterline. Each compressor has its own through-hull drainage fitting. It is advisable to check the flow of water visually once the air conditioning starts running.

Operation

Before starting the engine:

- Open the raw water intake valves and evacuation valves;
- Make sure that the control panel is in the STOP position;
- Use the switch on the chart table to select the power source (shore power or generator).
 - If using shore power: plug into the shore power socket;
 - If using the generator: before turning on the air conditioning, leave the generator running for approximately 3 minutes.

If the seawater pump is deprimed (eg. in case of running aground), carry out the following procedure:

- Disconnect the discharge hose from the seawater pump by loosening the 2 stainless steel collars;
- Blow air through the pipe using a compressor;
- Re-connect the discharge hose with 2 stainless steel collars.

When the air conditioning is running:

- Switch the air-conditioning circuit-breakers ON.
- Select the temperature of each compressor using the control units.

DIAGRAM

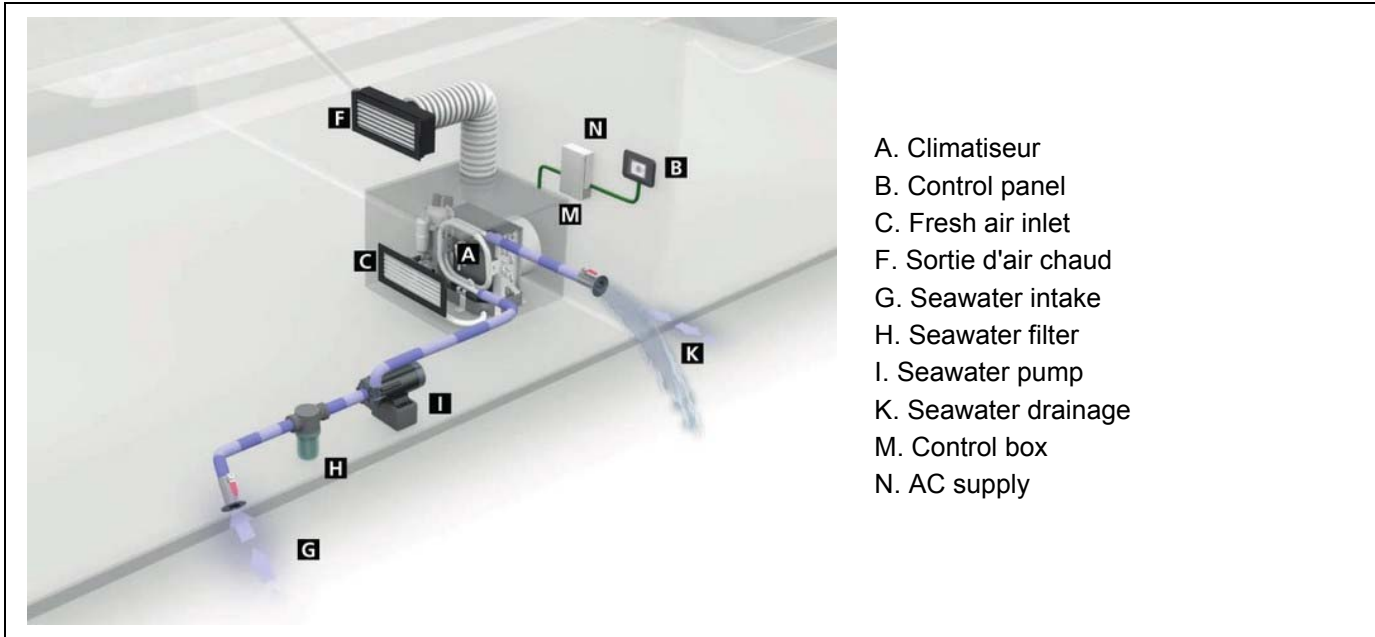

- ! - Refer to the manufacturer's instructions for use and maintenance.
- When the air conditioning is running, check visually that the seawater has been fully drained.
- Never start the generator when the air conditioning is already on.
- Always turn off the air conditioning before turning off the generator.
- Regularly check and clean the seawater filter placed on the thru-hull seawater intake:
 - Close the seawater intake valve;
 - Unscrew the top of the filter;
 - Clean the filtering screen;
 - Put everything back in place.
- Clean the air filter (located in the compressor) regularly for maximum performance.
- Clean the cooling coil at least once a year.
- To prevent the air-conditioning circuit from freezing: never run the system when the seawater temperature drops below 5°C.
- Winterisation: drain the whole seawater system.
- The cooling gas circuit requires no maintenance.

Air-conditioning controls

- The air conditioning is controlled from Ship Control (see Chapter: SHIP CONTROL). A remote control is installed in each cabin.

Air conditioner (Location)

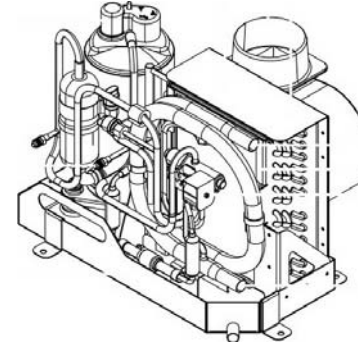
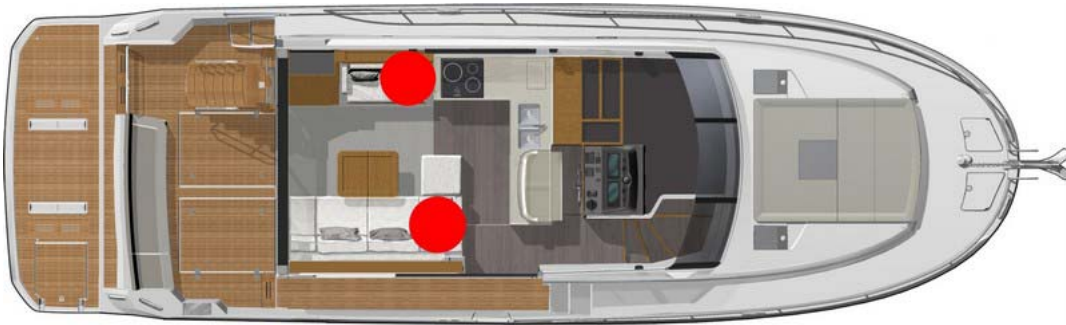

Location: Cockpit locker



1. Seawater intake
2. Seawater filter
3. Seawater pump

LAYOUT OF AIR CONDITIONING WIRING LOOMS

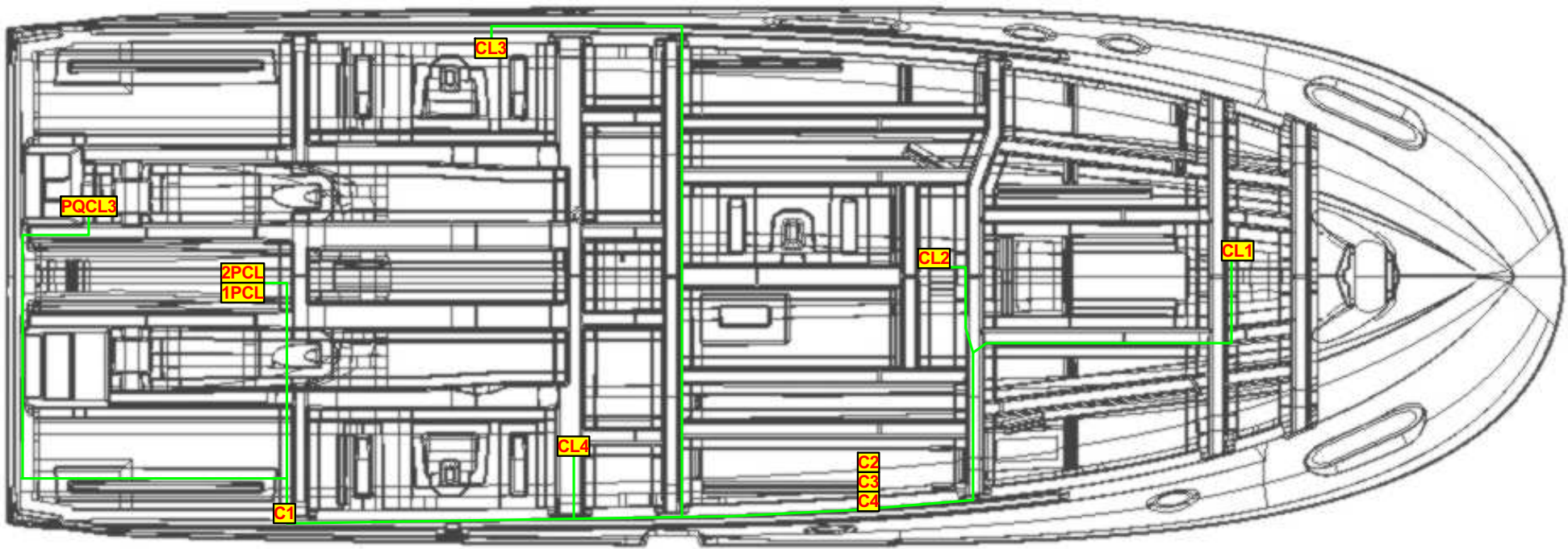

11.2 ELECTRONIC EQUIPMENT

The onboard electronics are powered by direct current.

Electronic equipment can also be controlled from Ship Control (see Chapter: SHIP CONTROL).

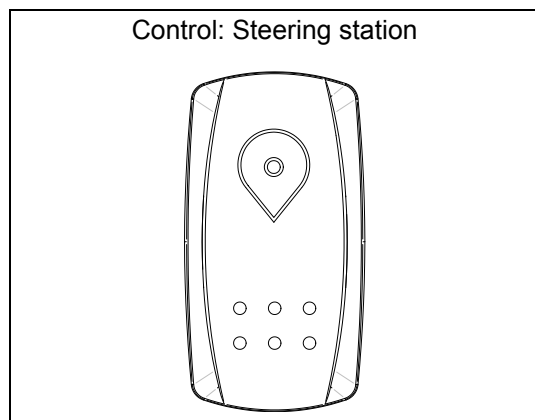

Sensors

- Do not store equipment on top of the sensors.
- Do not cover the sensors in antifoul when antifouling the hull.
- Regularly clean the sensors.

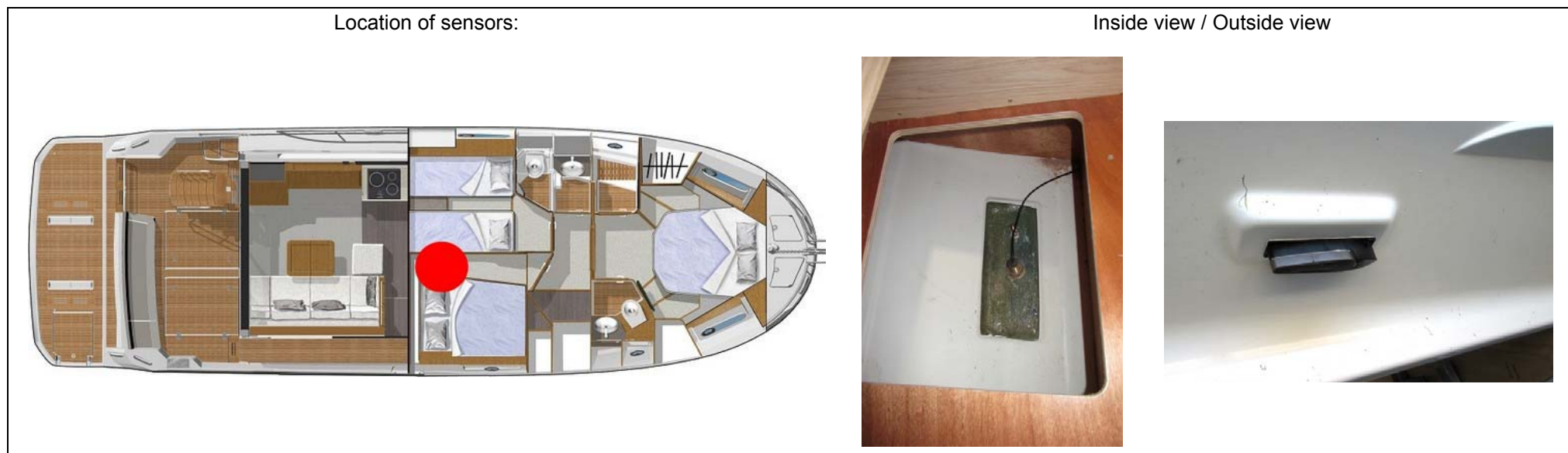

Augmented reality

- The augmented reality module is a sensor comprising a GNSS receiver (global satellite navigation system) and a AHRS sensor (course and trim reference system). The module provides position, course, pitch and roll data to the compatible multi-function screens.
- When combined with a compatible camera, the module can be used for the ClearCruise™ augmented reality functions available on the multi-function screen.
- The augmented reality system runs on 12V and is protected with a fuse.
- The camera must be calibrated whilst underway by a professional.



- Please refer to the manufacturer's instructions for use of the electronic system.

Camera

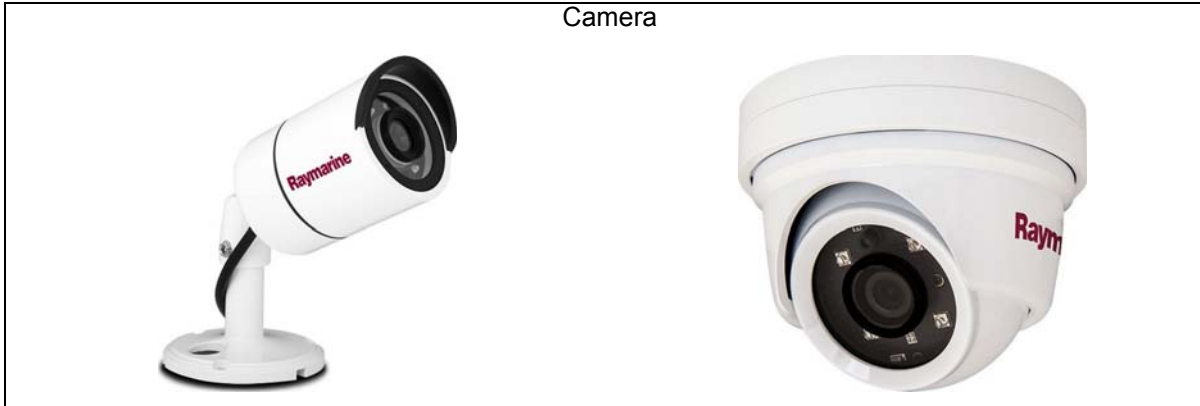

Augmented reality module



Autopilot

- To ensure optimum performance, keep all metallic objects away from the gyrocompass.
- Do not store equipment close to the calculator and electrical connections.

LAYOUT OF COMPONENTS



Ref 1:



A. Hydraulic piston
B. Vessel Management Unit

Ref 2: Gyrocompass



Control:

Interior steering station



Flying bridge steering station



VHF

Layout of components:









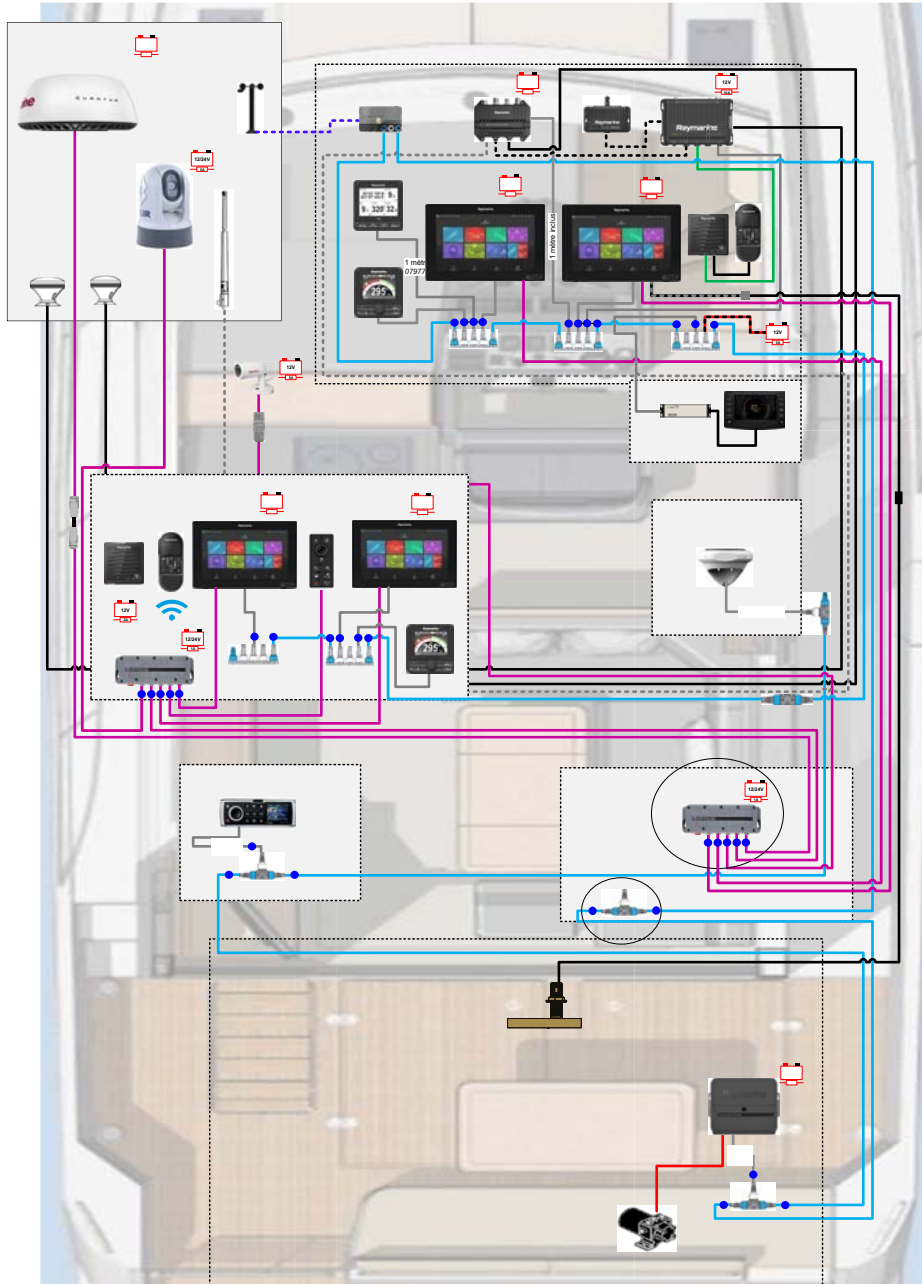

AIS aerial (Flying bridge)

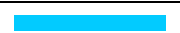

- Place the protective covers on the repeaters when unused for long periods.
- When sailing, store the protective covers inside the boat to avoid loss.
- The various repeater displays are back-lit.
- Regularly clean the dials of the repeaters with fresh water.
- Refer to the manufacturer's instructions for use and maintenance.

DIAGRAM OF LAYOUT



	Seataalk1
	Ridge Seataalk NG
	Specific to the product
	RayNet
	Connection Seataalk NG
	Video
	VHF
	Label BJT

11.3 FUEL-BURNING EQUIPMENT FOR PURPOSES OTHER THAN PROPULSION (GENERATOR, HEATING)

11.3.1 General points

- Make sure that the ventilation openings in the engine (and, if installed, generator) compartment are well-cleared.
- Stop the engine and refrain from smoking while the fuel tank is being filled.
- Have your fuel circuit checked regularly by a professional engineer.
- Avoid any contact between inflammable materials and the hot sections of the engine.
- Take all necessary precautions to avoid contact with naked flames and other hot areas.
- Do not obstruct or modify the ventilation system.
- Fuel stored outside the tanks (jerrycans, portable fuel tanks, etc.) must be stowed on deck and protected from bad weather and mechanical damage.



- Never store fuel tanks or tanks containing petrol in any area not specifically designed for storing petrol.



Beware of the risk of falling asleep due to carbon monoxide inhalation. This is a risk associated with petrol engines..

11.3.2 Generator

DIAGRAM OF LAYOUT

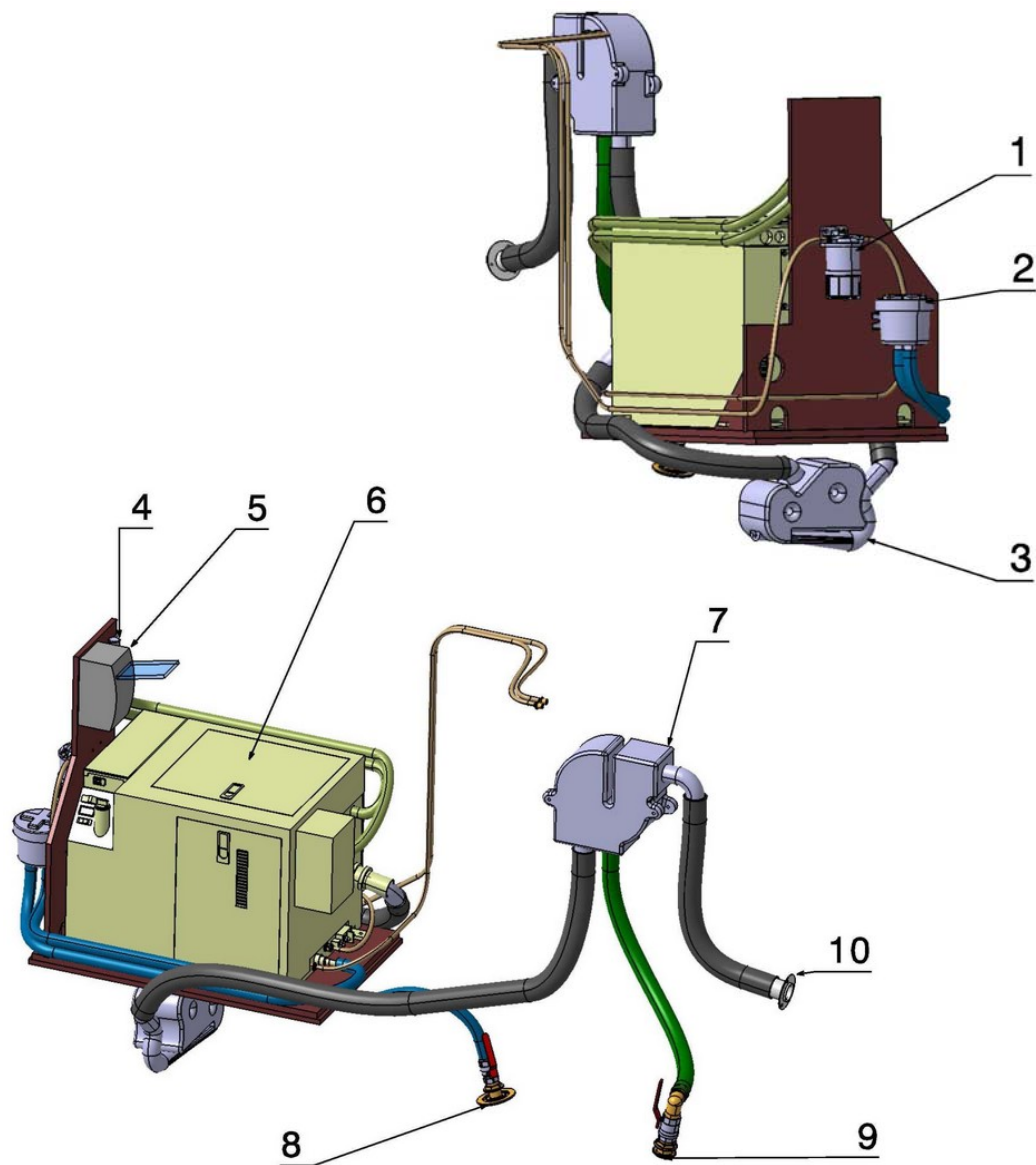

Reference	Designation
1	Fuel filter
2	Seawater filter
3	Water trap
4	Anti-siphon valve
5	Differential circuit breaker
6	Generator
7	Water/gas separator
8	Seawater inlet
9	Seawater drainage
10	Outlet

General points

- The generator is a machine which can produce AC electrical power using mechanical power (fuel). The generator powers onboard equipment operating at 220V or 110V, moored or sailing.
- The generator starts with its own battery (12V circuit).
- Make sure that there is enough fuel in the fuel tank before using the generator. The generator is fed by fuel from the port fuel tank.
- The cooling water and exhaust gases are separated in the separator to avoid noise pollution. The seawater is discharged below the waterline. The exhaust- pipe is located above the waterline. Check visually that the exhaust gases are being expelled properly.
Make sure that the ventilator in the generator compartment is working.
- Check to see if any leaks appear (seawater, coolant, fuel, exhaust gases). If there is a leak, stop the generator at once and have the leak repaired.
- The generator is earthed by an earthing plate which is located under the hull (see Chapter: EARTHING PLATES).
- Maintenance of the generator must only be done by qualified and proficient personnel. Before working on the generator, it is imperative to isolate the generator's battery power, to prevent it from starting accidentally.
- The generator can be started by the switch on the generator itself or by the switch on the control panel.

Starting up

- Fill the generator with water to prevent the seawater pump from running dry (refer to the supplier's recommendations).
- Open the raw water intake valves and evacuation valves.
- Open the fuel supply valve.
- Turn the generator's battery switch to the ON position.
- Switch the generator's circuit-breaker to the ON position.
- Turn on the generator using the remote control (Touch screen).
or on the generator itself.
- Make sure that no AC equipment is running. Toggle the shore power/ generator switch.

In the event of the generator catching fire

- Do not open the generator.
- Cut the power supply (electrical and fuel) to the boat's engines, to the generator and to the ventilators.
- Use the extinguisher access port on the generator to discharge the contents of the portable extinguisher.



- ! - Refer to the manufacturer's instructions for use of the generator.
 - Never start the generator when the air conditioning is already on. Always turn off the air conditioning before turning off the generator.
 - Never connect the shore power to the generator: you may suffer an electric shock.
 - An extinguisher access port is provided on the generator in the event of a fire starting in the generator.

LAYOUT OF COMPONENTS

Cockpit locker



1. Seawater filter
2. Battery
3. ON / OFF control
4. Extinguisher access port

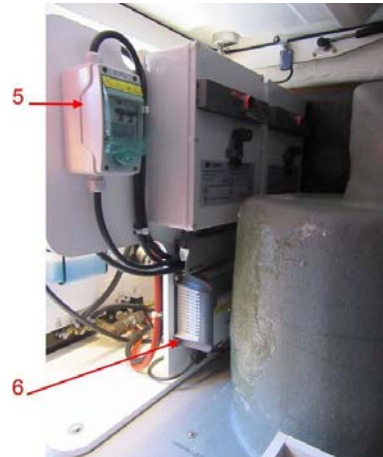

5. "Onboard" power circuit breaker
6. Battery charger



7. Fuel filter
8. Engine compartment ventilator
9. Negative isolator switch
10. Positive isolator switch
11. "Air conditioning" supply circuit breaker

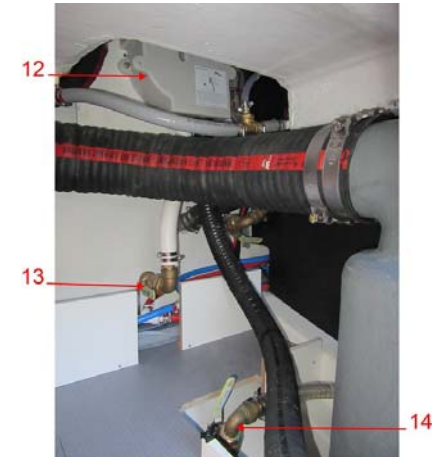

12. Water/gas separator
13. Seawater drainage
14. Seawater intake

Remote control (Touch screen)



11.3.3 Water heating

The water pump and the diesel pump are built into the heater. The cabins and saloon are fitted with heating units to which the water piping is connected.

The fluid used for the heating is a mixture of water and coolant.

The correct fuel is diesel. Be aware of the hazards associated with using the incorrect fuel.

Heater
Location: Cockpit locker



Layout of components: Cockpit locker

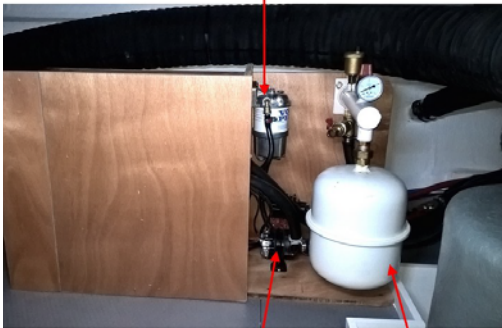

1. Fuel filter
2. Fuel pump
3. Expansion tank



- Please refer to the manufacturer's instructions for the use and maintenance of the heating system.

- A sudden cut in the electrical supply may damage the heater: REMEMBER TO SWITCH OFF THE HEATER BEFORE ISOLATING THE BATTERIES.

- It is essential to disconnect the electrical supply and to allow the hot components to cool before doing any maintenance or work on the heater.

Heating unit

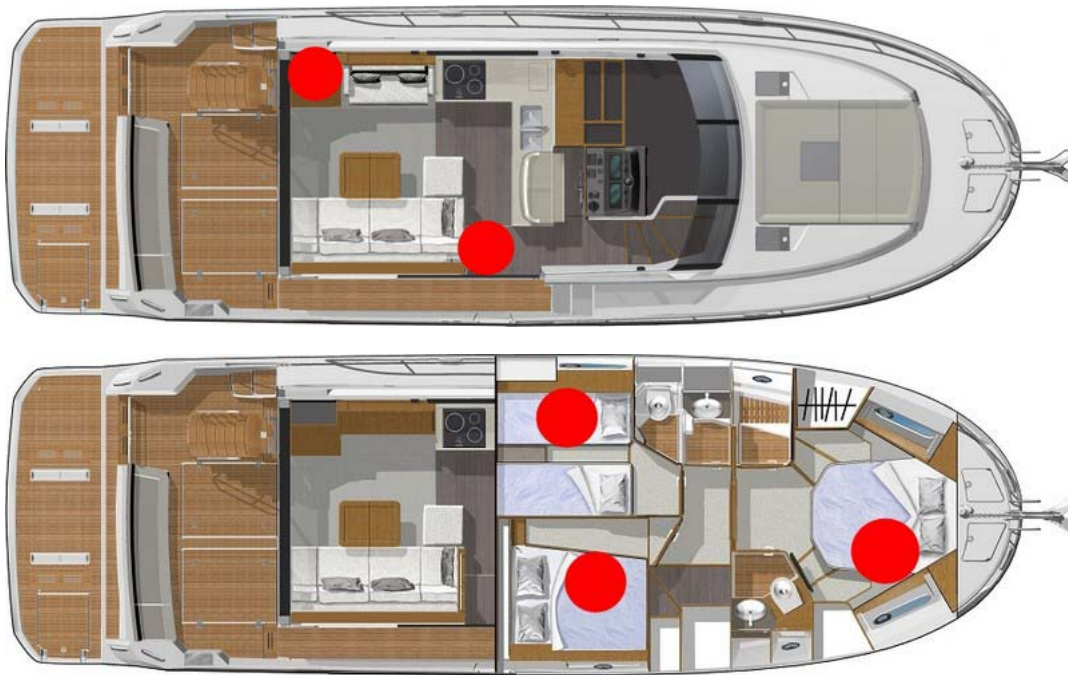

- 1. ON / OFF control
- 2. Thermostat (in each cabin)

Fuel supply valve (Port tank)

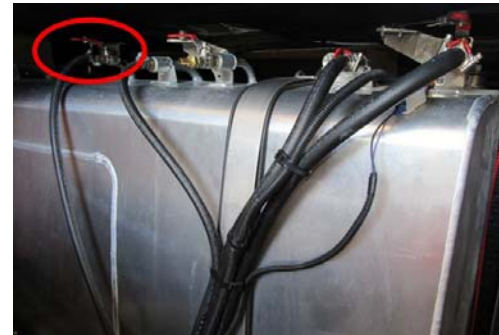

SCHEMATIC DIAGRAM OF WATER CIRCUIT

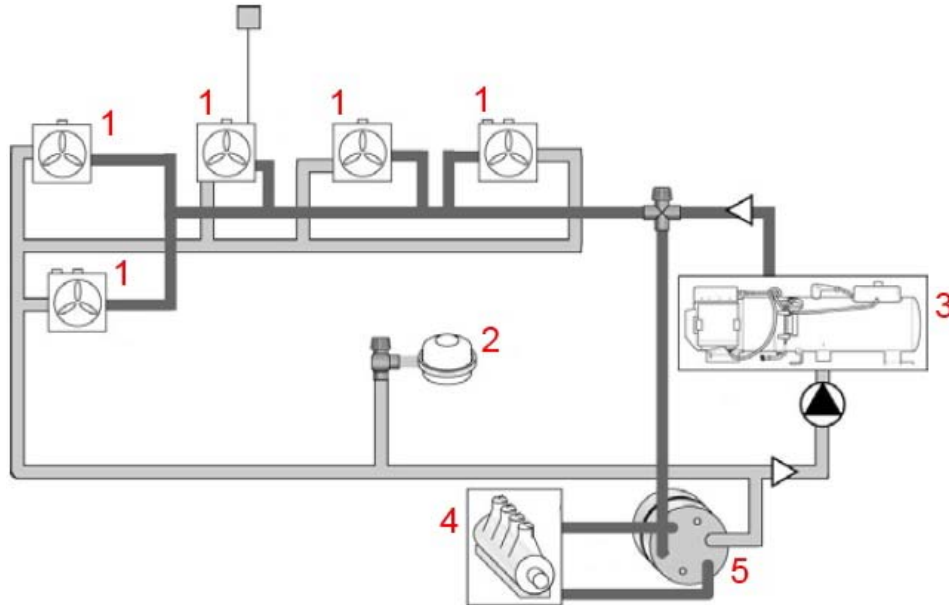

Reference	Designation
1	Heating unit
2	Expansion tank
3	Heater
4	Propulsion engine
5	Water heater

Servicing and maintenance

- To ensure optimum operation of the heating circuit, be sure to operate the heater once a month, even in the Summer, to prevent the seals from drying out or the metering pump and burner motor from seizing
- You are advised to perform a complete servicing of the heating circuit every 3 years.
- The burner combustion chamber must be replaced every 10 years.
- If the boat is to be used for oceanic sailing, provide yourself with a maintenance kit and a diagnostic device.

❌

- The heater must be switched off when refilling the fuel tank.
- The heater's exhaust gases are very hot: they may burn fenders or cables located too close to the through-hull exhaust.

⚠️

- The heater and its components may be hot during and immediately after operation and may cause injury if touched.
- The air at the outlets of the heater may be hot and can cause injury if a part of the body (e.g. the legs) remains exposed for a long time to the flow of hot air.
- Before switching on the heating, make sure that the combustion air, exhaust and heating air intake and outlet ports are not obstructed while the heater is running.
- Never store inflammable material near the heater.

📖

- Reduce the amount of reserve fuel as much as possible; use tanks made of corrosion-resistant material.
- Store the reserve fuel tanks on deck. Avoid exposure to temperatures exceeding 60°C (see Chapter: ENGINE).

LAYOUT OF THE HEATING WIRING HARNESSES

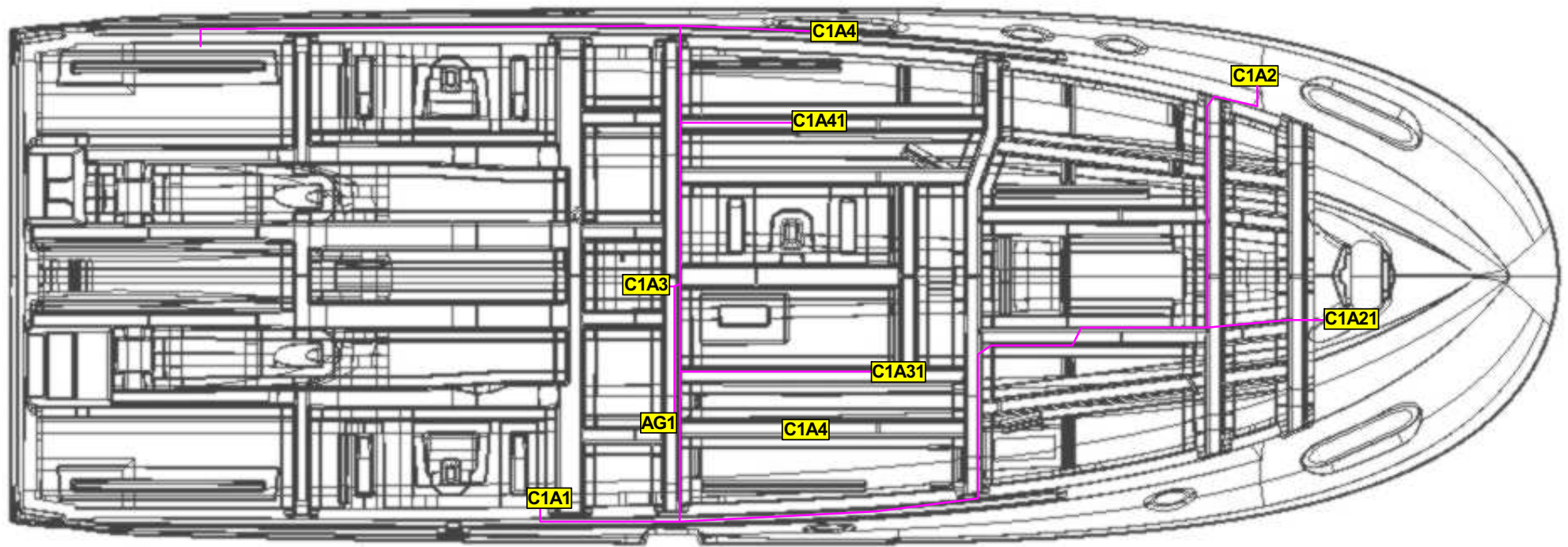

WATER SYSTEMS

■ General points	170
■ Using a valve.....	171
■ Fresh water filling system	172
■ Fresh water distribution system	173
■ Main plumbing equipment.....	174
■ Blackwater system (Toilet)	182
■ Waste water system	188

12.1 GENERAL POINTS

- It is essential to rinse the entire on-board water system the first time the boat is used (the water system is protected in the factory by a non-toxic antifreeze).
- The water tanks may have had an anti-algae treatment using a copper sulphate based product. It is advisable to renew the treatment according to the area in which the boat is sailing.
- Drain all the water systems during winterisation (in particular the cockpit shower and water heater) to avoid damage from freezing.
- Clean/change the filters regularly.



- Regularly check water-tightness of joints in the water system installations. Check that screws and bolts are well tightened and replace them if they are worn or corroded.
- Disconnect the onshore shore water supply before leaving the boat (if fitted).
- If the boat is sailing in temperatures below freezing, antifreeze can be used in the water systems: use a non-toxic antifreeze for potable water.

**NEVER USE AUTOMOBILE ANTIFREEZE:
RISK OF POISONING.**

12.2 USING A VALVE

The valve is closed when the valve handle is at right angles to the pipe. The valve is open when the valve handle is in line with the pipe.

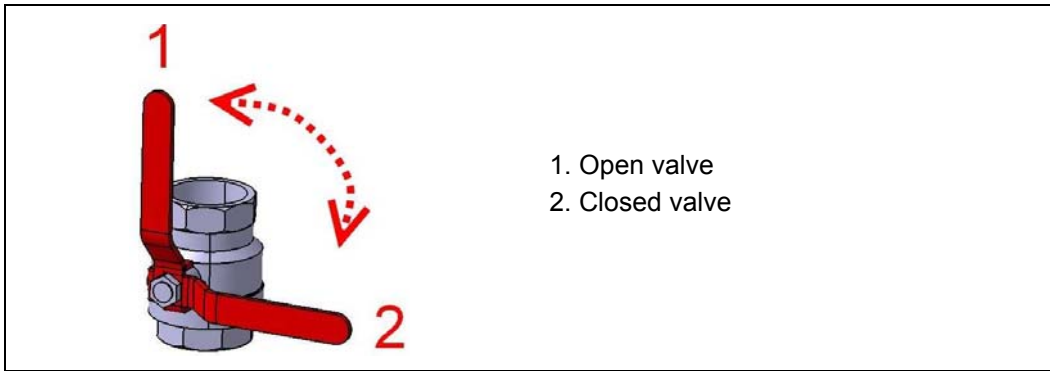

Using the drainage valve

- The direct-to-sea drainage valve can be sealed by means of the drilled hole on the handle.
- To lock the drainage valve in the closed position: Pass the tightening collar around the drainage valve and feed through the hole in the handle as shown.

Plastic valve



Bronze valve



Valves, thru-hull inlets and other brass or bronze fittings have a lifespan of around 5 years. All valves, thru-hull inlets and other brass or bronze accessories must be checked by a professional every year and replaced as necessary.



- Beware of any unintentional draining.

12.3 FRESH WATER FILLING SYSTEM

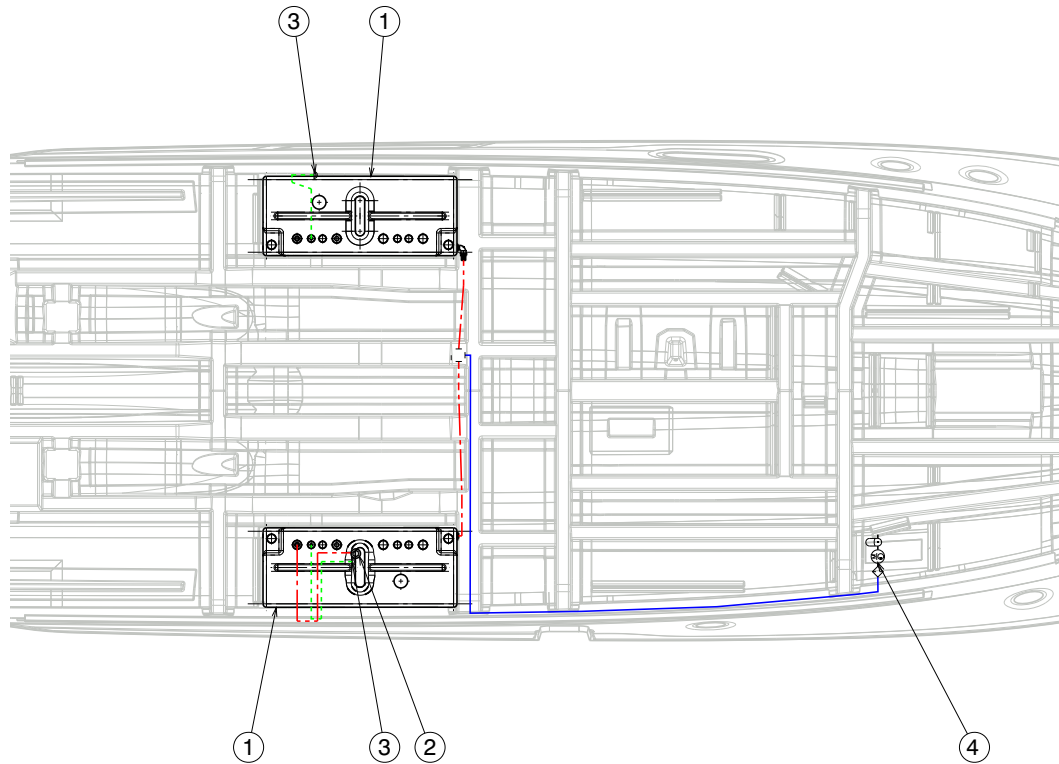

Reference	Designation
1	Water tank
2	"WATER" deck filler
3	Water tank vent
4	Water unit

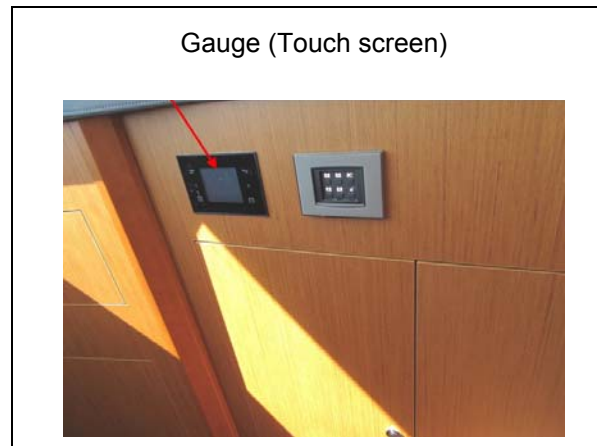
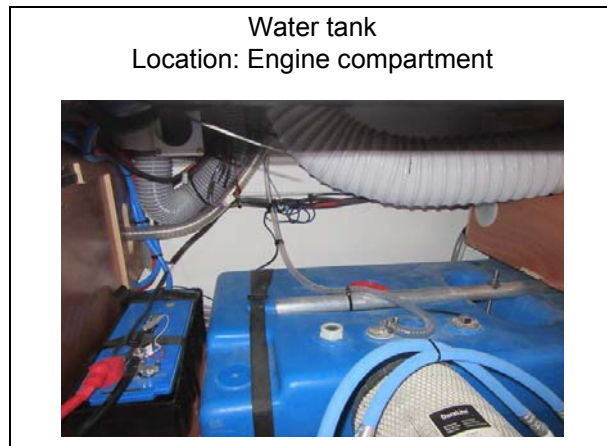

12.4 FRESH WATER DISTRIBUTION SYSTEM

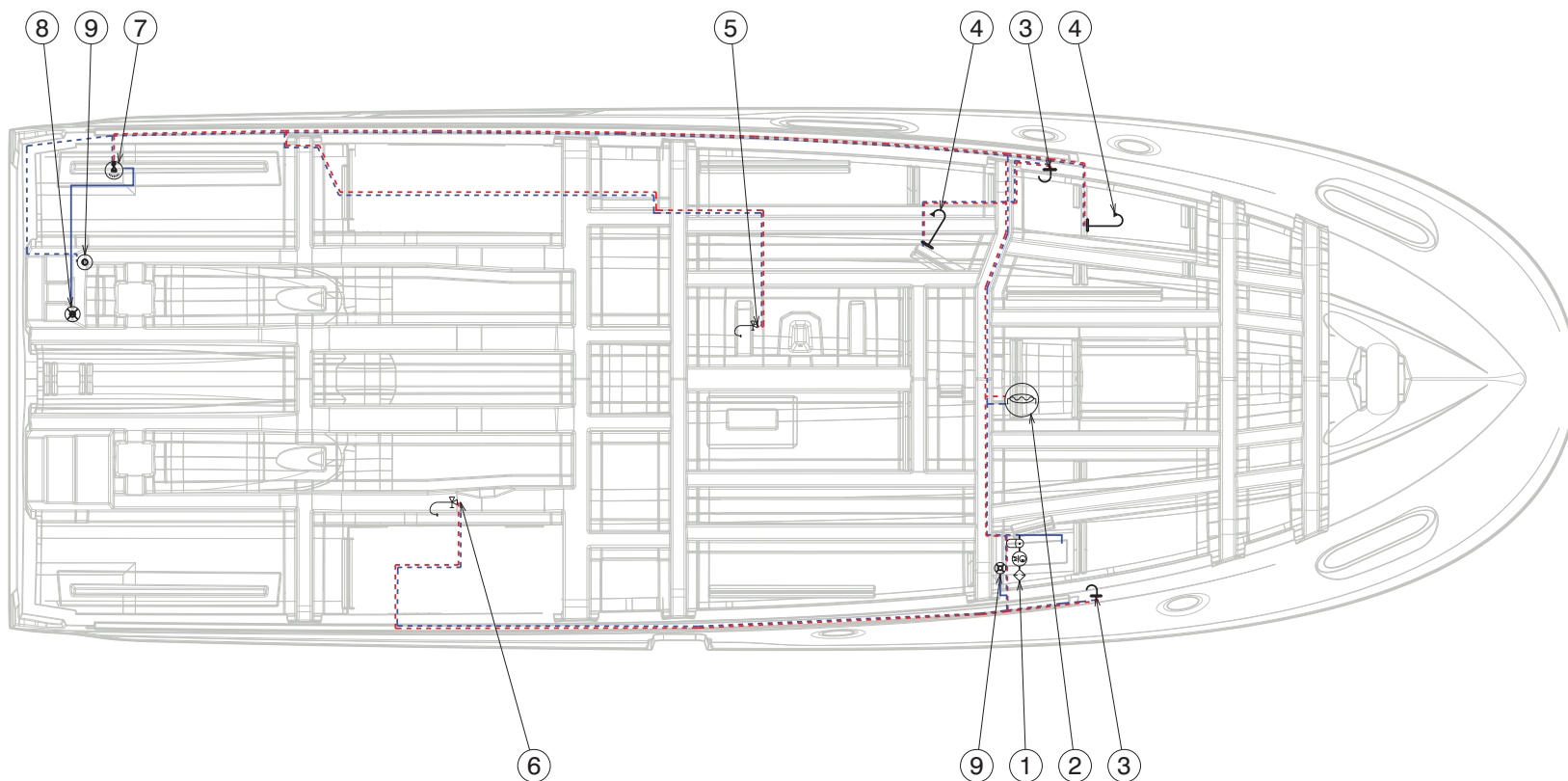

Reference	Designation
1	Water unit
2	Water heater
3	Head washbasin
4	Shower
5	Galley sink
6	Flying bridge sink
7	Cockpit shower
8	Fresh water shore supply
9	Deck washing outlet

12.5 MAIN PLUMBING EQUIPMENT

12.5.1 Water unit

- The water unit is powered by direct current.
- It supplies all the boat's plumbed-in equipment with fresh water. It is fitted with a pressure switch that activates the flow when the pressure in the water system falls.
- The water unit must only be used with the fresh water supply. All other use (e.g. seawater, bilge water, oil products) must be strictly avoided.
- The water pump is switched on at the helm station.
- Make sure that the water unit never runs dry.
- The pressure and capacity of the water unit depend on the temperature of the stored fresh water supply.

Control: Steering station

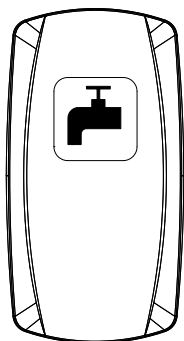

Location: Companionway



1. Fresh water filter
2. Water unit

12.5.2 Cockpit shower

- The cockpit shower provides fresh water for rinsing off.
- The shower is fitted with a mixer tap.
- The tap has a dual function:
 - It allows the water to be turned on or off,
 - It allows a choice of water temperature (hot water / cold water).

Operation

- To use the shower, turn on the water by tipping the tap on its axis.
- Press the button on the top of the shower to allow the flow of water.
- Choose the required temperature by turning the tap clockwise or anti-clockwise.
- After using the shower, it is important to turn off the water by tipping the tap back into its original position.



12.5.3 Deck wash pump (House water)

- The deck wash pump is supplied by direct current.
- The deck wash pump allows the deck or the boat's tender to be washed.
- The deck wash pump is switched on at the helm station.

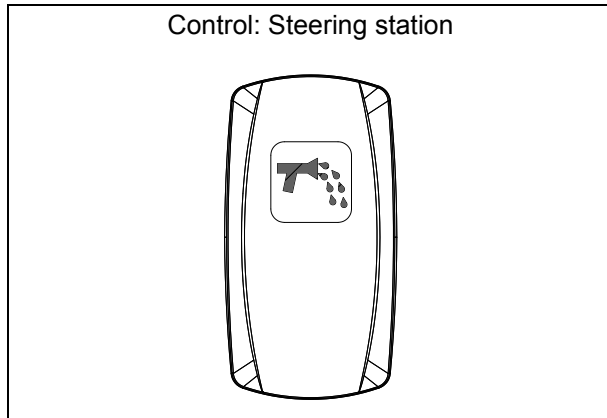

Operation

- Attach a hose to the connector provided in the cockpit.
- Start the pump.

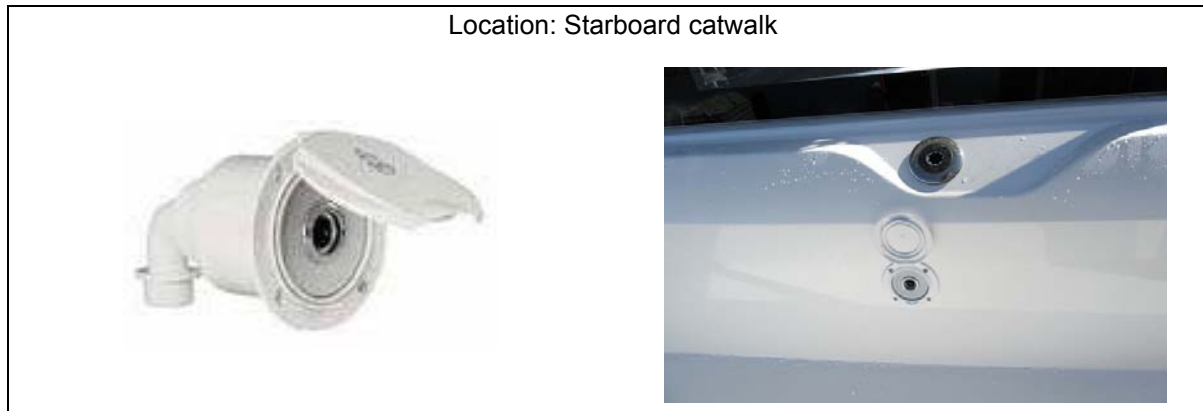

12.5.4 Shore fresh water supply

General points

There are two options for supplying the fresh water circuit of the boat:

1. via the water unit supplied by one or more water tanks,
2. by fresh water taken from the dock.

These two possibilities of supplying fresh water circuit of the boat are independent from each other.

1. Supply of the fresh water circuit by the water unit and the water tanks

- Open the valve of the desired water tank located near the water unit (if the boat has several water tanks, it is advisable to open only one valve at a time).
- Switch on the water unit.

2. Supply of the fresh water circuit by taking fresh water from the dock

- Connect a water pipe to the onshore water supply.
- Open the water supply tap located on the pontoon.
- A non-return valve in the distribution circuit allows the shore supply water to be used without opening the valve.
- The connection of the water intake is located in the cockpit.

Location: Cockpit

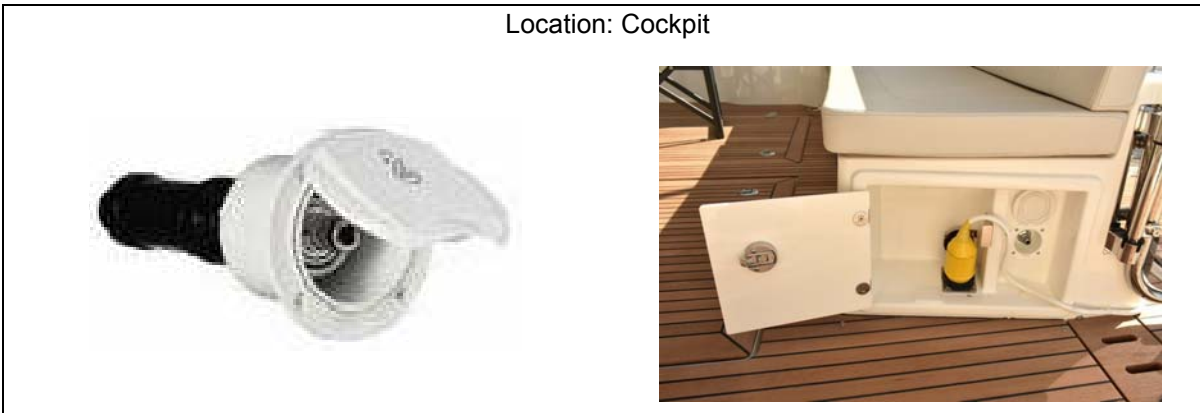

 Disconnect the onshore shore water supply before leaving the boat.

NOTES

- The water from the onshore supply is delivered under pressure directly into the onboard water circuit. It is not necessary to switch on the water unit.
- It is not possible to fill up the water tanks using the onshore water supply.

12.5.5 Water heater

- The water heater enables the use of hot water on board the boat.
- The water heater operates by recovering heat from the starboard engine cooling circuit or by means of the boat's AC electrical circuit.
- The water heater thermostat regulates the water temperature only when it is operating with electrical resistance. The thermostat is pre-set in the factory.
- The mixer tap allows the temperature leaving the water heater to be adjusted.
- Never switch on the water heater if it is not filled with water.
- A valve allows the water heater to be connected to the heat exchanger. This valve allows a faulty circuit to be isolated.

 Refer to the manufacturer's instructions for use and maintenance.

Location: Passageway



Mixer tap



Starboard engine / water heater cooling circuit supply valve



12.5.6 Ice making equipment (Ice maker)

General points

- The ice maker provides a supply of ice from the onboard water system.
- The ice maker runs on the AC power supply.
- A circuit-breaker protects the circuit.

Operation

- The ice maker is supplied with water from the tanks via a supply valve.
- Turn on the water unit to supply water to the ice maker.
- Open the onboard water/ice maker supply valve.
- Turn on the AC power (shore or generator) and actuate the ice maker circuit-breaker.
- Start the ice maker using the control on the appliance.

Maintenance

- A carbon filter is installed in the ice maker water system. Change the filter regularly.
- Clean the evaporator with a damp cloth at least once a year. Never use cleaners which are abrasive or acidic, or which contain solvents, for cleaning the evaporator.
- Clean the hinge of the ice maker door regularly with a damp cloth.
- Clean and defrost the ice maker regularly.
- During overwintering, leave the ice maker door open to avoid the formation of mould and odours.
- During prolonged absences, drain the ice maker system to avoid damage from freezing.

 - Refer to the manufacturer's instructions for use and maintenance.

- Never heat or use tools to defrost the inside of the fridge more quickly.
- Never obstruct the heat exchanger of the fridge.

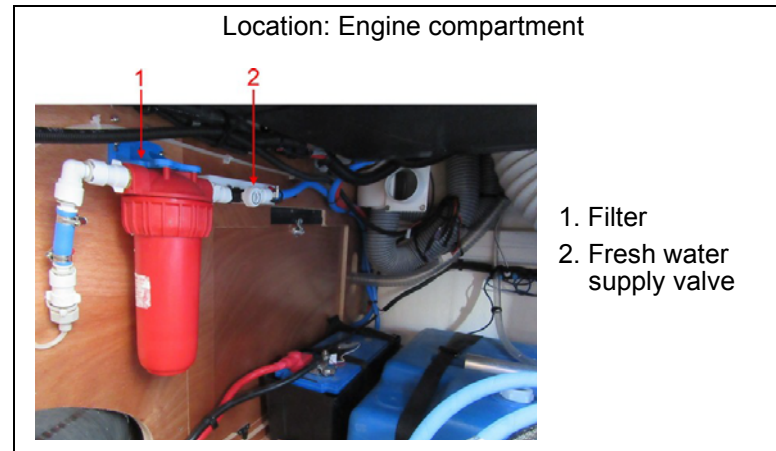
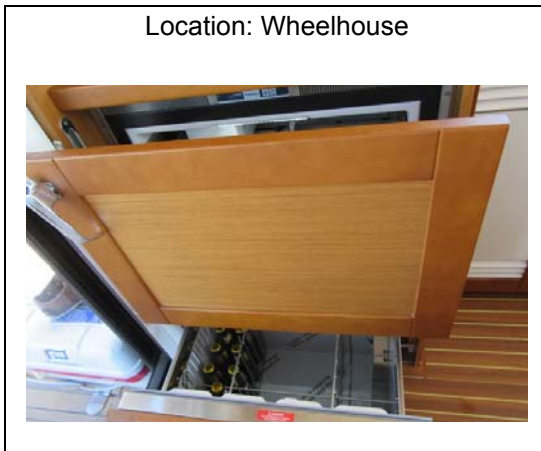

12.5.7 Watermaker

General points

- The watermaker allows fresh water to be produced from the seawater.
- The watermaker can be supplied either:
 - by DC (direct current),
 - by AC (alternating current).
- A circuit-breaker protects the circuit.
- The watermaker circuit comprises several elements:
 - seawater intake,
 - seawater filter(s),
 - circulation pump,
 - electric valve for automated rinsing,
 - manual rinsing valve,
 - motor block and high-pressure pump,
 - membrane block,
 - control panel,
 - seawater discharge valve.

Operation

- Seawater enters the membrane block under pressure, which allows only pure water to pass out.
- A sensor at the membrane block outlet allows measurement of the salt content of water filtered in this way. A three-way valve allows drinking water to be directed automatically to the tanks or for water that is too salty to be discharged to the sea.
- The drinking water filtered by the membranes is sterile; it is advisable to treat it with a weak dose of chlorine from time to time and to mineralise it if consumption is prolonged.
- Fresh water production is affected by the temperature of the seawater used and the cleanness of the filter.

Operation

- Before starting the watermaker circuit, check that the supply and discharge valves are open.
- Using the watermaker with DC supply needs a lot from the battery bank: make sure to recharge them regularly by running the boat's engine.
- The different quality and salinity of the seawater used affect the production of fresh water; it is advisable not to use the watermaker in areas of heavy sail traffic or where the water is muddy, polluted or brackish.
- The membranes are temperature-sensitive; in the event of negative (0°C and less) or too hot (60°C and over) temperatures, the membranes are likely to tear.

Maintenance

- Every week, rinse the system with fresh water. This can be done manually or automatically as preferred. The fresh water used for rinsing the circuit must not be under pressure as this can damage the membranes.
- Every 6 months, the seawater filter must be changed.
- When the watermaker is not being used for a long period, rinse the system every month or sterilise the membranes.

Motor unit

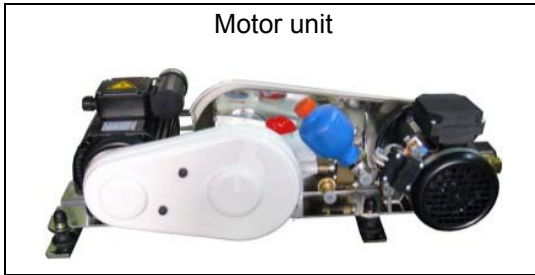

Control panel



Seawater filter



Electromagnetic valve



Membrane block

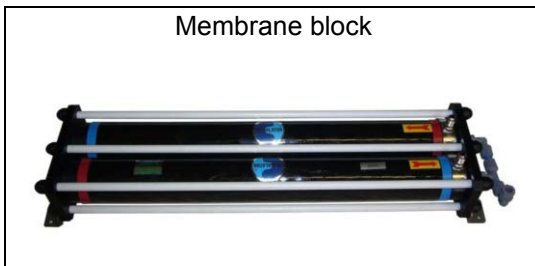

12.6 BLACKWATER SYSTEM (TOILET)

General points

- Blackwater is human waste including water flushed from the toilets.
- Close the valves after each use and especially when the boat is unattended.
- Regularly check the valves and thru-hull seacocks for proper operation and watertightness.
- Regularly check the tightness of the flexible pipe clamps and connections.
- The toilets can be supplied at choice by sea water or onboard fresh water. The choice is made on the toilet control.

WC supply by sea water



Food Freshwater WC



Toilet control



Electric "seawater" pump
Location: Companionway









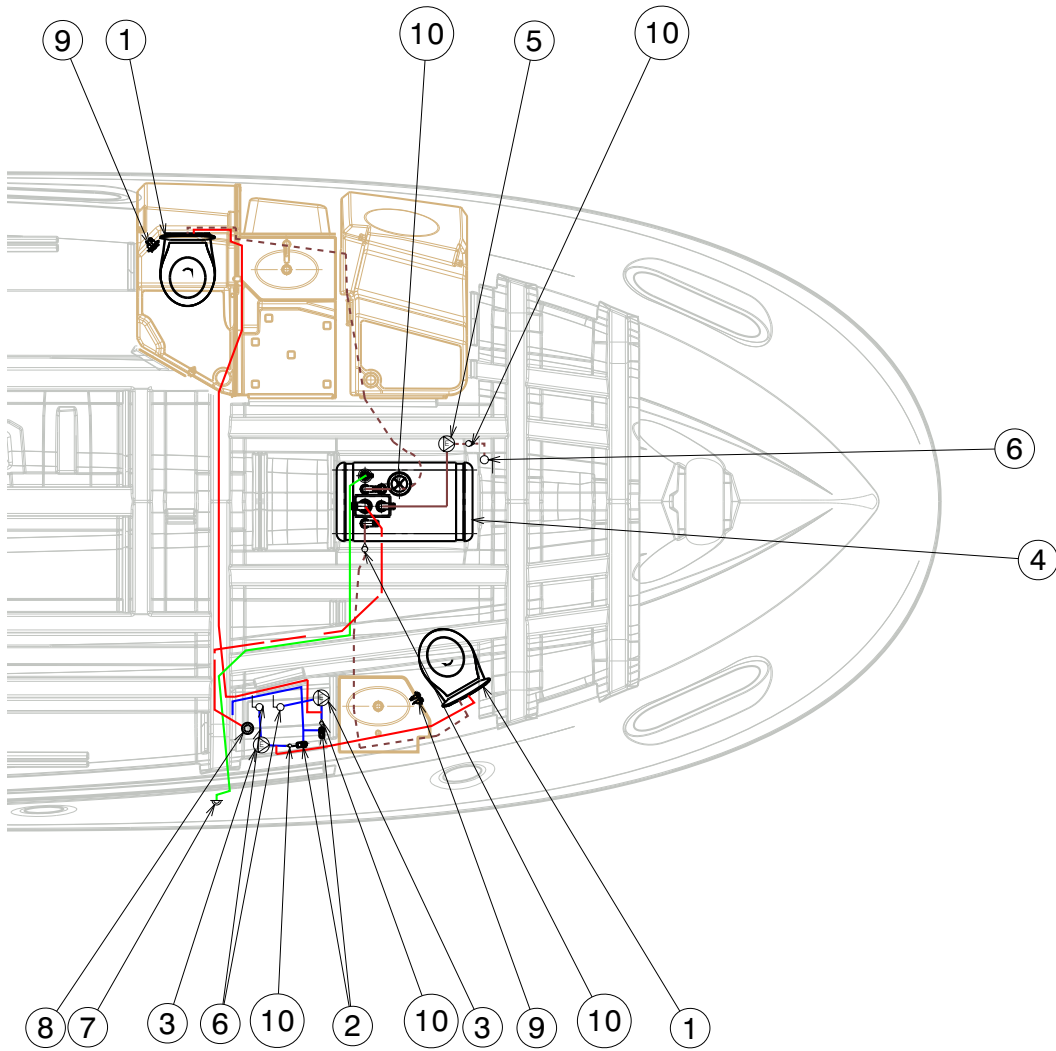

1. Seawater filter
2. Electric "seawater" pump
3. Electromagnetic valve

Seawater intake



12.6.1 Diagram of blackwater system



	Seawater supply
	Fresh water supply
	WC supply
	Vent pipe
	Drainage hose
	Suction hose
	Suction hose

Reference	Designation
1	Toilet
2	Electromagnetic valve
3	Seawater pump
4	Blackwater tank
5	Macerator (Pump for drainage of the blackwater tank to the sea)
6	Thru-hull fitting
7	Blackwater tank vent
8	Black water tank drainage cap (WASTE)
9	Toilet control
10	Non-return valve

YOUR BOAT IS FITTED WITH A BLACKWATER TANK

To minimise odours from this tank, we suggest following the use and maintenance guidelines below:

1) Holding tank

- A blackwater tank is used solely for the temporary collection of water from the toilets.
- The tank can be emptied in 2 ways:
 - By connection to a pumping system that empties the tank by suction. This system uses the "WASTE" deck connection.
 - Via the thru-hull fitting, which empties directly into the sea (provided that the laws of the country in which the vessel sails permit dumping into the sea).
- Only use water-soluble toilet paper to avoid blockages.

Note: Sanitary towels and other items (paper handkerchiefs, dressings etc.) in the toilets and blackwater tank will result in blockages.

- Faecal matter causes the formation of unpleasant odours in the blackwater tanks, to which the use of salt water for flushing the toilets also contributes. Algae present in salt water also give off unpleasant odours.
- Completely empty the blackwater system before leaving the vessel unattended in temperatures below freezing.
- Ask for information about the laws in force in your country or your marina about discharging your waste waters into the sea.

2) Use of toilets

- Every time the toilets are used, flush afterwards with copious amounts of water in the bowl using the toilet pump (manual or electric).
- When you are leaving the boat for several days, flush with fresh water. You may wish to use the shower in the head for this purpose. Seawater allowed to stagnate in the bowl gives off bad odours.

Blackwater tank
Location: Forward cabin

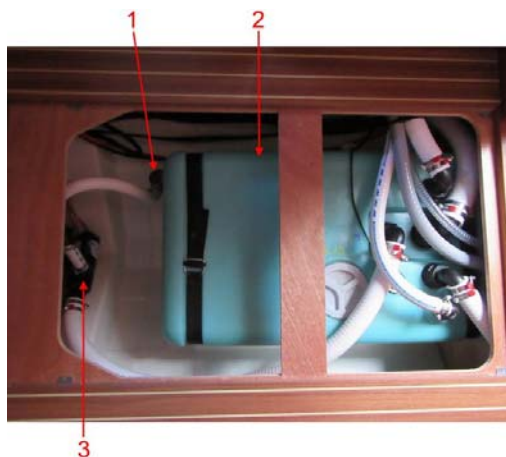

1. Drainage of blackwater tank into the sea
2. Blackwater tank
3. Macerator (Pump for drainage of the blackwater tank to the sea)

Blackwater tank gauge & Masher control
Location: Touch screen



NOTE: The valve must be opened before starting the pump.

3) Maintenance of blackwater tank

- The risk of unpleasant odours forming increases when the waste water remains in the tank for a long time.
- Whenever possible empty the tank regularly, even before it is full.
- Every time the tank is emptied put in about 5 litres of fresh water and add an appropriate detergent additive (available from chandleries). A very simple method is to add soda salts, which clean and disinfect at the same time.
- Before winterising, flush the tank with copious amounts of fresh water filling it through the 'WASTE' deck connection. Leave at least 5 litres of fresh water mixed with a detergent additive.
- Disinfecting: Disinfect the tank once a year by filling it with a solution of Javel water (1 to 1000).

4) Using the drainage valve

- The direct-to-sea drainage valve can be sealed by means of the drilled hole on the handle.
- To lock the drainage valve in the closed position: Pass the tightening collar around the drainage valve and feed through the hole in the handle as shown.



 Never use automobile anti-freeze in the blackwater system: risk of poisoning.

 Respect local regulations regarding the emptying of blackwater tanks.

 - Beware of any unintentional draining.

Layout diagram of blackwater system
Drainage by electric pump DC (Macerator)

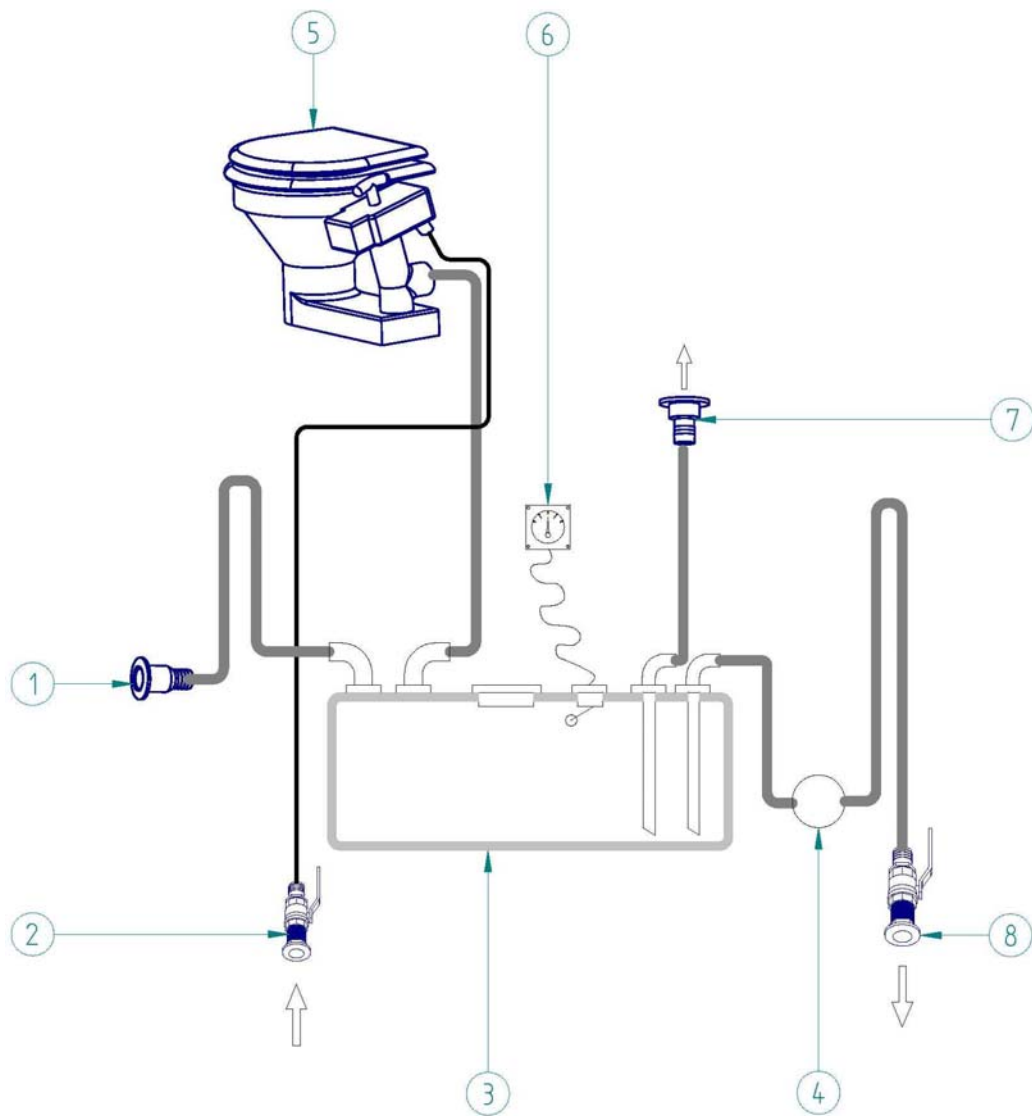

Reference	Designation
1	Vent
2	Seawater intake valve
3	Blackwater tank
4	Macerator (WC drainage pump)
5	Toilet
6	Gauge
7	"WASTE" deck connection
8	Sea discharge valve

Using a marine toilet with a tank drain by macerator

- I. Open the seawater intake valve (Ref 2).
- II. Fill the bowl by using the manual toilet pump.
- III. Using the toilet (Ref 5).
- IV.a. To empty the organic waste in the tank:
 - Make sure the thru-hull seacock (Ref 8) is closed.
 - Empty the bowl using the manual toilet pump.
- IV.b. For direct discharge into the sea:
 - Open the thru-hull seacock (Ref 8).
 - Empty the bowl using the manual toilet pump.
 - Empty the tank by switching the electric pump (Ref 4).
- IV.c. To discharge through the deck:
 - Open the deck connection marked "WASTE" (Ref 7).
 - Use the pump-out system where fitted at a port.

Use of a DC electric toilet has a tank-discharge macerator

- I. Open the seawater intake valve (Ref 2).
- II. Fill the bowl by pressing the fill button.
- III. Using the toilet (Ref 5).
- IV.a. To empty the organic waste in the tank:
 - Make sure the thru-hull seacock (Ref 8) is closed.
 - Empty the bowl by pressing the empty button.
- IV.b. For direct discharge into the sea:
 - Open the thru-hull seacock (Ref 8).
 - Empty the bowl by pressing the empty button.
 - Empty the tank by switching the electric pump (Ref 4).
- IV.c. To discharge through the deck:
 - Open the deck connection marked "WASTE" (Ref 7).
 - Use the pump-out system where fitted at a port.



Refer to the manufacturer's instructions for use and maintenance.

12.7 WASTE WATER SYSTEM

General points

- Waste water comprises the water coming from the sink, showers, air conditioning drains and washbasins. All of this water is collected in the greywater tank and drained via a discharge pump controlled by a float switch.
- Close the valves after each use and especially when the boat is unattended.
- Regularly check the valves and thru-hull seacocks for proper operation and watertightness.
- Regularly check the tightness of the flexible pipe clamps and connections.

Use of the waste water tank

- A sensor with automatic pump activation enables the tank contents to be emptied. If the onboard electricity system is off the tank will not empty.
- When the DC supply light shows, a 3-minute drainage cycle automatically starts up.



Observe local regulations regarding the emptying of greywater tanks.

Collector - Waste water
Location: Passageway

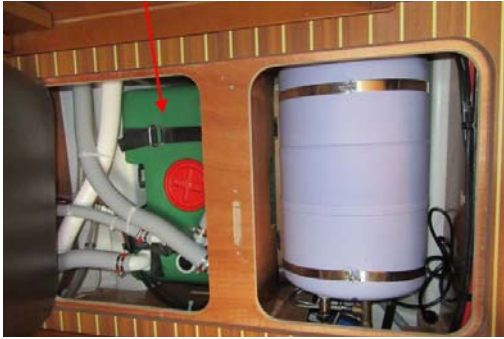

Shower screen



NOTE: It is essential that the shower screen remains locked in place when under way.

Collector drainage pump to the sea
Location: Companionway



Shower plug hole



Waste water drain valve to the sea



12.7.1 Diagram of waste water circuit installation

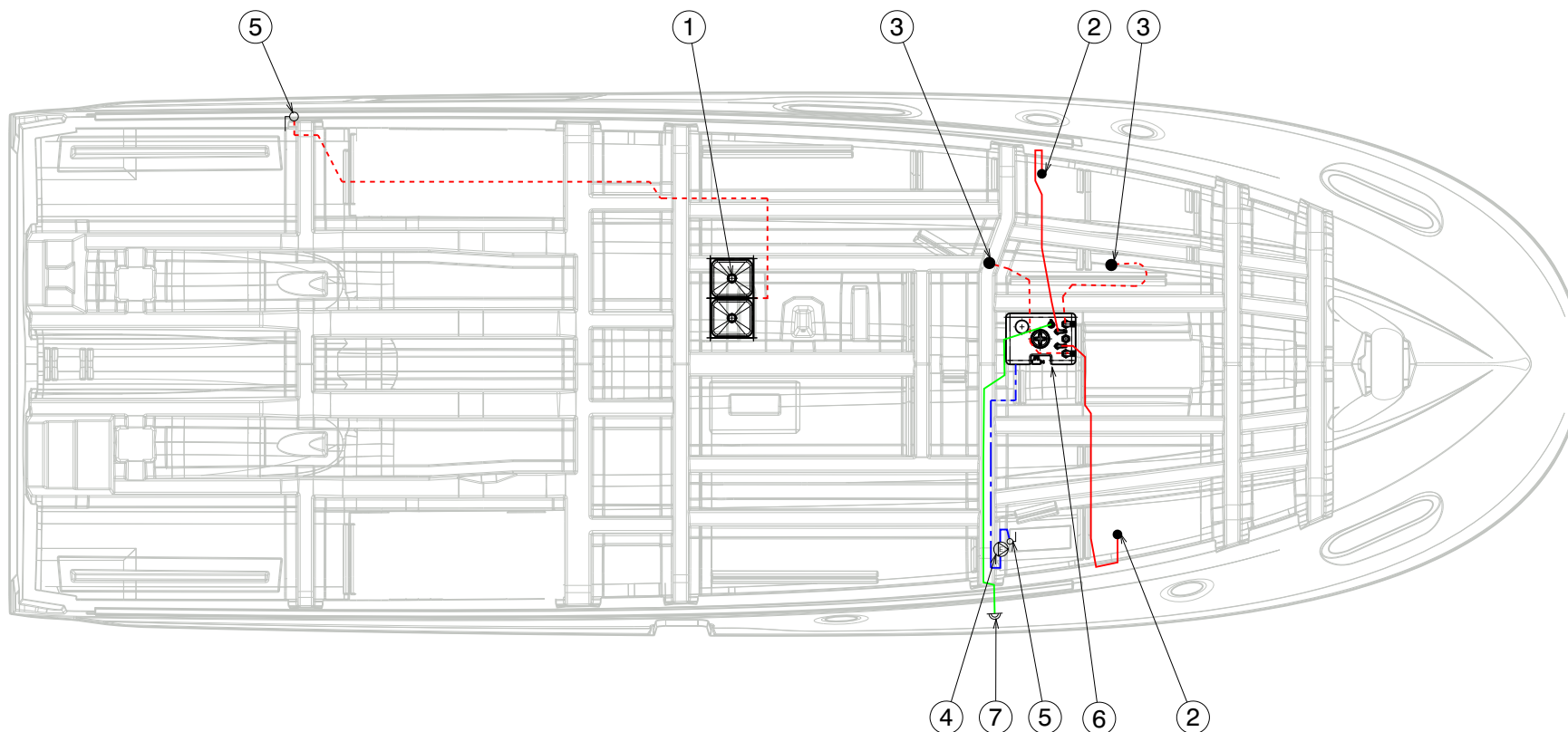

Reference	Designation
1	Galley sink
2	Head washbasin
3	Shower plug hole
4	Waste water drain pump
5	Kitchen sink thru-hull drainage
6	Waste water tank
7	Waste water tank vent

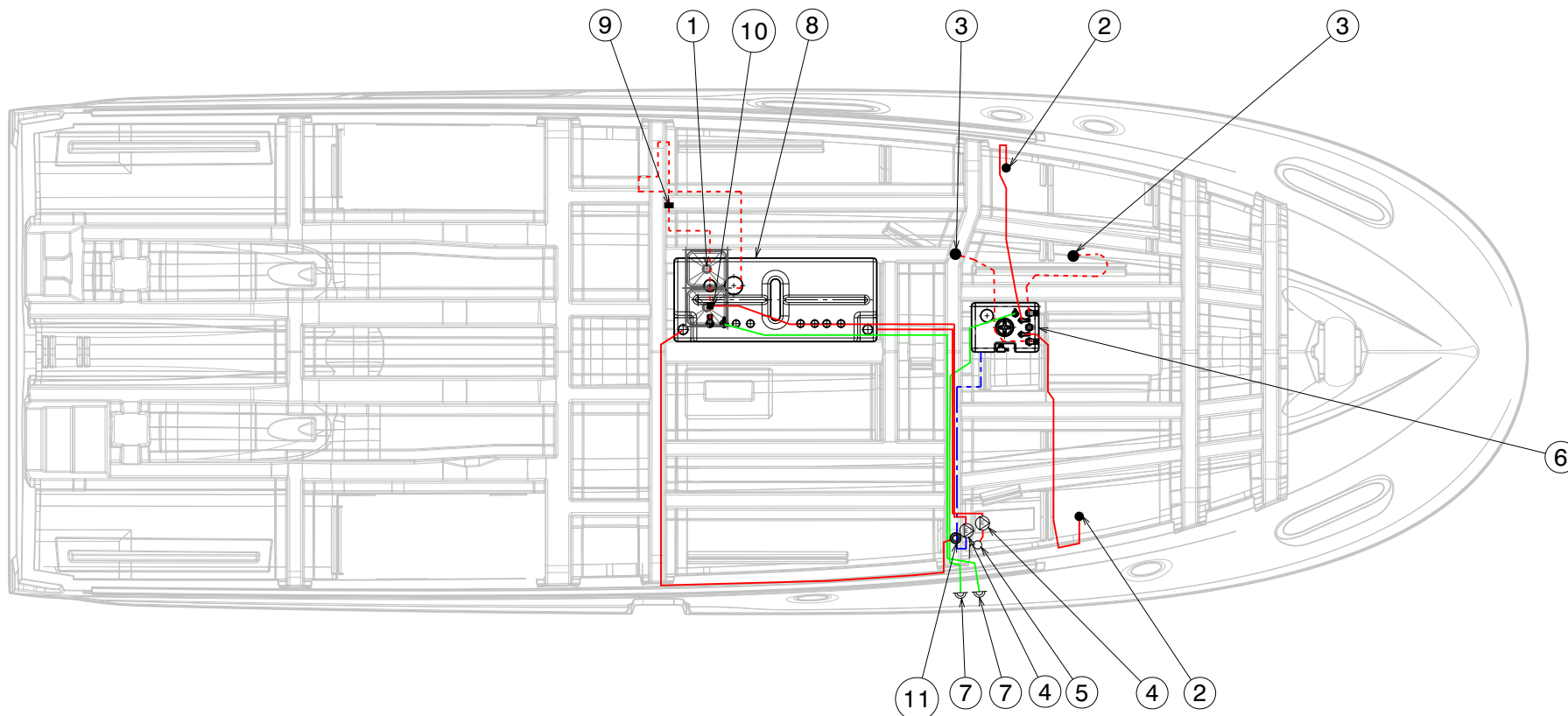

Reference	Designation
1	Galley sink
2	Head washbasin
3	Shower plug hole
4	Waste water drain pump
5	Kitchen sink thru-hull drainage
6	Waste water tank
7	Waste water tank vent
8	Extra tank
9	Connection
10	Connector
11	Waste water drain nozzle (WASTE)

ENGINE

■ Information relating to fire risks and risks of explosion.....	194
■ Danger from moving mechanical parts	195
■ General points	195
■ Starting the engine	198
■ Engine water intake valve.....	199
■ Anti-siphon valve.....	200
■ Fuel filter	201
■ Engine installation.....	202
■ Engine control	205
■ Access to the engine.....	205
■ Flaps	206
■ Propeller shaft	208
■ Stern gland.....	209
■ Propeller	210

13.1 INFORMATION RELATING TO FIRE RISKS AND RISKS OF EXPLOSION

- Make sure that the coolant is circulating properly.
- Ensure that the engine compartment ventilation air inlets are kept clear.
- Stop the engine and refrain from smoking while the fuel tank is being filled.
- Have your fuel circuit checked regularly by a professional engineer.
- Avoid any contact between inflammable materials and the hot sections of the engine.
- Never switch off or cut off energy to the electric system when the engine is running.
- Never block access to the fuel supply valve.
- Do not obstruct or modify the ventilation system.
- Never turn the engine over when the boat is on land.
- Fuel stored outside the tanks (jerrycans, portable fuel tanks, etc.) must be stowed on deck and protected from bad weather and mechanical damage.
- Regularly check that the engine compartment is clean and dry.

Engine water intake valve
Location: Engine compartment



Fuel supply valve
(located directly on the tank)



13.2 DANGER FROM MOVING MECHANICAL PARTS

- Keep away from the drive shafts and the mechanical parts of the engine when they are in motion (including belts, moving parts and hot components).
- Be careful if you have long hair, bulky clothing, rings etc. (these may become caught).

13.3 GENERAL POINTS

- Do not install an engine more powerful or heavier than recommended for this boat, since doing so may compromise the boat's stability.
- Any alteration or modification to the exhaust system of the propulsion engine(s) is prohibited.
- Make sure you have enough fuel before sailing.
- Stop the engine before opening the engine compartment.
- Do not close the fuel supply valve between each use of the engine (except in the event of prolonged disuse).
- Get the whole propulsion system checked at least once a year by a professional engineer.

see Chapter: MANOEUVRABILITY.

Always start the engine with the control lever in neutral.

Type of motorisation

Your boat is fitted with two in-board diesel engines.

Transmission type is: Propeller shaft.



- Regularly check that the O ring on the filler cap is in good condition to prevent water ingress.
- Keep the fuel tank as full as possible to prevent condensation.
- Be careful with any possible risk of oil and fuel spillage.
- Follow the engine manufacturer's instructions exactly.
- **Never switch off the battery isolators when the boat's engine is running (risk of serious damage to the charging circuit).**

Filling up with fuel

- Fill the fuel tank by opening the cap marked "DIESEL", provided for this.
- Regularly check that the O ring on the filler cap is in good condition to prevent water ingress.
- Each fuel supply valve supplies one engine.
- The generator has its own fuel supply valve.

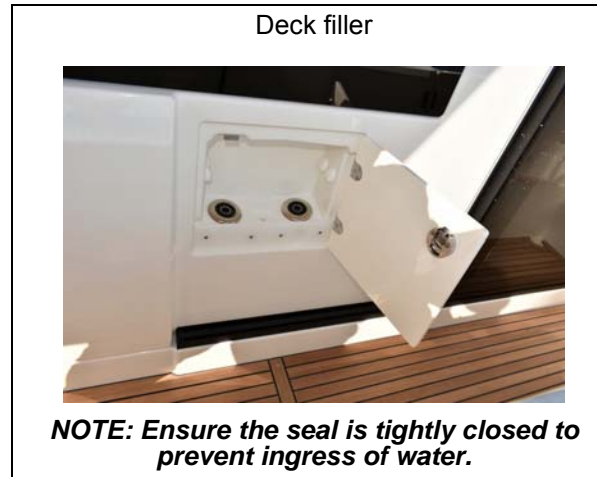
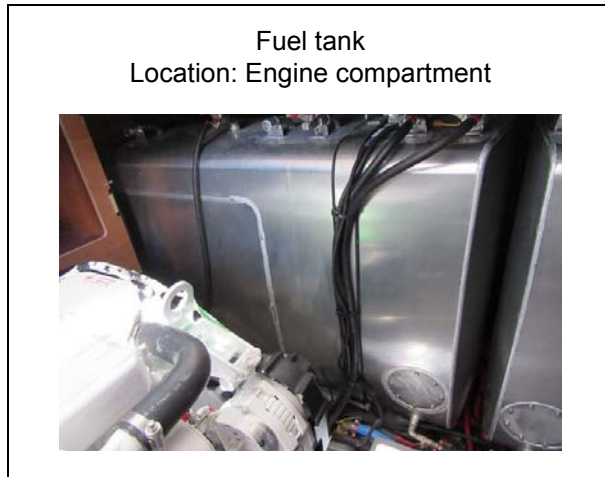

Tank interconnecting valve

- A valve enables the two tanks to be interconnected.
- Keep the 2 connection valves closed at all times to avoid the transfer of fuel from one tank to the other (risk of emptying one tank and disabling one engine).
- Open the interconnection valves only to balance the tanks or if there is a problem with the fuel supply.



Gauge

- The fuel level is transmitted via the gauge to the indicator on the steering station.
- Some of the gauges must be calibrated when you first fill the tanks: please consult your dealer.



 The tanks' nominal capacity cannot be fully used due to the load and the need to maintain the correct trim. A 20% reserve should be kept.

13.4 STARTING THE ENGINE

Before starting the engine, it is essential:

- to open the fuel supply valve;
- to open the seawater intake valve of the engine;
- to switch on the battery supply by using the battery isolator switches;
- to put the control lever in neutral.

Make a habit of looking to see if seawater is pumped out with the exhaust gases as soon as you start the engine. If no water runs out, stop the engine immediately. Check the coolant flow.

The engine compartment bilge fan is activated automatically when the engine is started.



Before using the engine, make sure you carefully read the handbook provided by the engine manufacturer.



- Always start the engine with the control lever in neutral.
- Learn how to judge the necessary distance of deceleration for the vessel to come to a complete stop (the reverse gear is not a brake).

13.5 ENGINE WATER INTAKE VALVE

The seawater intake valve plays a crucial role in ensuring that the engine runs well.

- Keep the filter under the hull as clean as possible;
- Brush the filter whenever the boat is lifted out.

This valve must absolutely always be opened before starting the engine.

A seawater filter filters the water before it goes through the heat exchanger.

Regularly inspect the seawater filter and clean it if necessary. Screw/unscrew the cover of the filter by hand (never use tools).

For lengthy absences, close the engine's seawater intake valve.

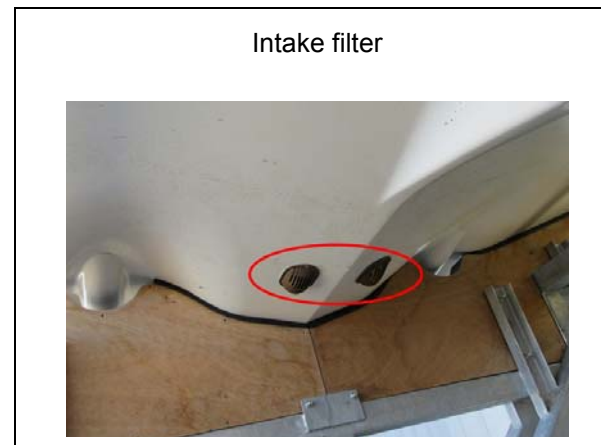

13.6 ANTI-SIPHON VALVE

- The function of the anti-siphon valve is to inhibit the siphoning action when the engine stops, thus preventing a backflow of water.
- It is possible that on starting the engine or at certain engine speeds some drops of water may be seen escaping from the anti-siphon valve.
If this occurs, you must clean the anti-siphon valve: dismantle the water collector at the top of the anti-siphon valve, then clean the valve with fresh water to remove any impurities.
- Then do the reverse procedure to refit the cleaned component, taking care not to refit the valve the wrong way round.
- It is advisable to carry out this simple preventative maintenance procedure on the anti-siphon valve once a year.



13.7 FUEL FILTER

Engine running problems may stem from various causes, including dirty fuel. The injection pump may wear out if there is water in the system. The water results either from condensation resulting from an insufficiently filled tank, or from a filler cap which has either not been closed properly or which has a damaged seal.

In order to prevent any water infiltration, the fuel runs through two filters:

- One filter is an integral part of the engine; its role is to filter fuel very finely. Please refer to the engine manufacturer's notes for any maintenance and for the frequency of filter changes.
- The second filter is on the pipe that links the tank to the engine; it works as a water decanter and prefilter.

Maintenance

- Purge the impurities by unscrewing the screw located at the base of the decanting bowl (without removing it). Let the liquid run into a receptacle until the fuel runs clear. Do this several times a year.
- Change the pre-filter at least once a year.

Location: Engine compartment



13.8 ENGINE INSTALLATION

Installation of shaft engine with bracket

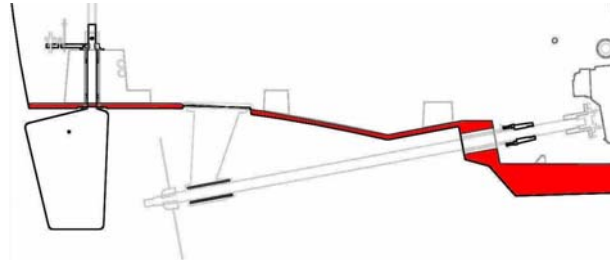
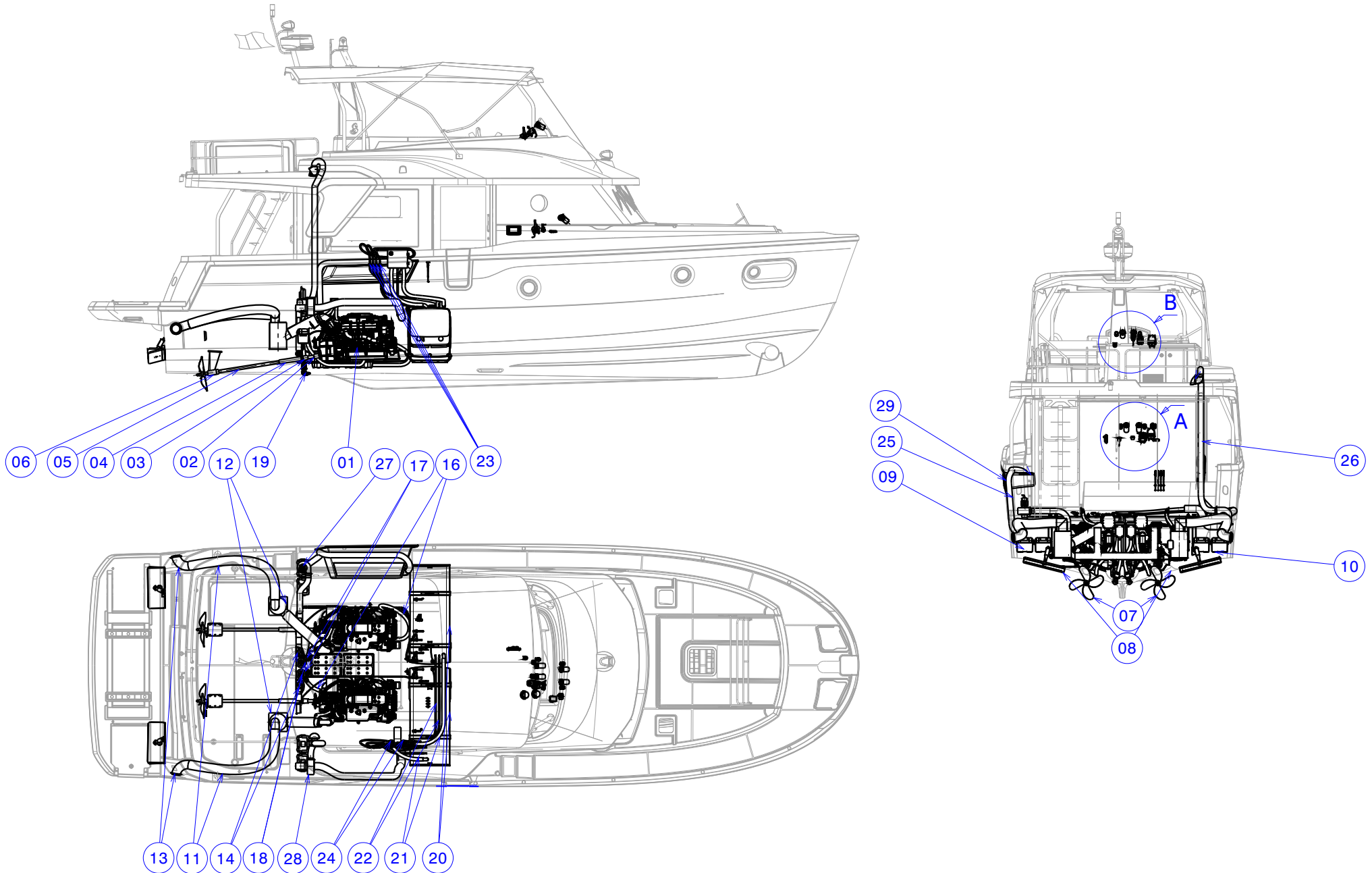
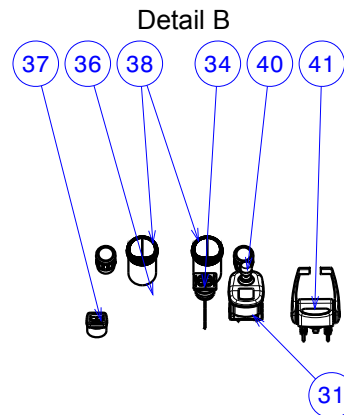
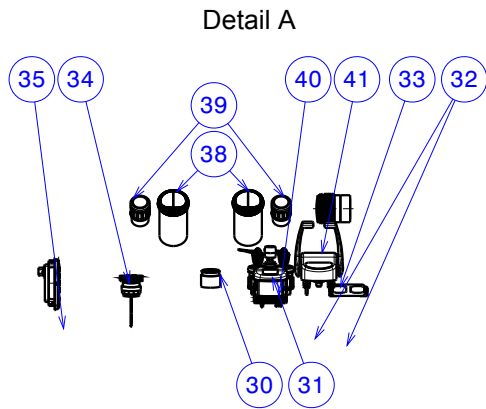

DIAGRAM OF LAYOUT





Reference	Designation
1	Propulsion engine
2	Connecting rod
3	Stern gland
4	Stern tube
5	Propeller shaft
6	Bearing
7	Propeller
8	Flaps
9	Port engine battery
10	Starboard engine battery
11	Outlet
12	Water trap
13	Connection
14	Expansion tank
16	Seawater intake
17	Seawater intake valve
18	Seawater filter
19	Thru-hull fitting
20	Fuel tank
21	Hose

Reference	Designation
22	Vent
23	Anti-flooding valve
24	Fuel filler
25	Fresh air suction
26	Hot air outlet
27	Ventilator
28	Ventilator
29	Air intake
30	Engine control panel
31	Bow thruster control
32	Starting
33	Engine case
34	Flaps control
35	Engine diagnostic socket
36	Emergency engine stop
37	Engine START / STOP
38	Rev counter
39	Fuel gauge
40	Joystick
41	Engine control lever

13.9 ENGINE CONTROL

- The engine manufacturer's notes provide detailed explanations on how to operate the engine and keep it running well.
- Read the manufacturer's notes on use and maintenance of the engine.

Control lever

- The control lever is fitted with a safety system which prevents the engine from starting when in gear.

Engine control lever



1. Joystick (for manoeuvring the vessel at low speed)
2. Engine control lever

Engine instrument panel



13.10 ACCESS TO THE ENGINE

Access to the engine can be gained via:

- The wheelhouse.

All access hatches to the must strictly be kept shut when at sea.

13.11 FLAPS

General points

- The flaps (trim control system) allow the pilot to adjust the boat's trim under way and thus to reduce fuel consumption.
 - The flaps run on DC power.
 - A fuse protects the electrical circuit.
 - They are operated by means of a push button situated on the wheelhouse and their position is adjustable.
 - The flaps work only when the boat's engines are running.
-
- The flaps are controlled electrically.
 - The actuator is mechanical.
 - The flaps must be protected by an anode (see Chapter: ELECTRICAL SYSTEM).

Operation

- When the flaps are lifted, the boat's bow tends to rise from the water.
- When the flaps are lowered, the boat's bow tends to go down into the water.

Maintenance

- Clean the flaps regularly with clean water.
- When cleaning the hull, coat the flaps and piston with antifouling paint. Do not cover the section below the anode or the anode itself with antifouling.



- Refer to the manufacturer's instructions for use and maintenance.
- Adjust the flaps gradually to avoid abrupt hull movements. At high speeds, take care when adjusting the flaps.
- Lift the flaps completely in case of swell from abaft of the boat.

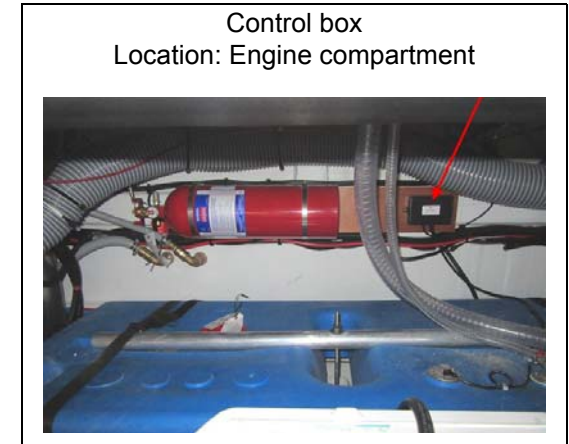
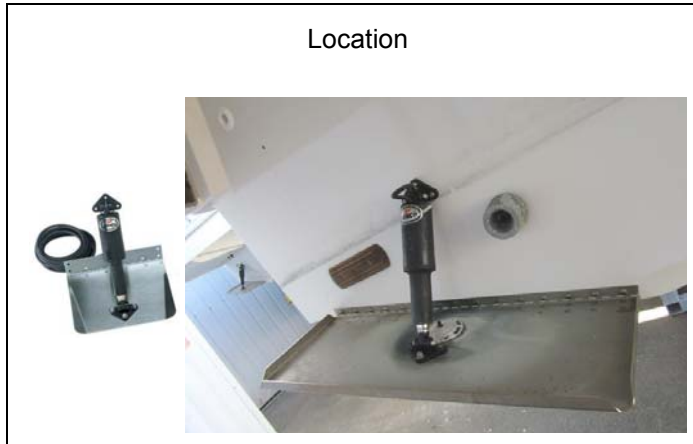
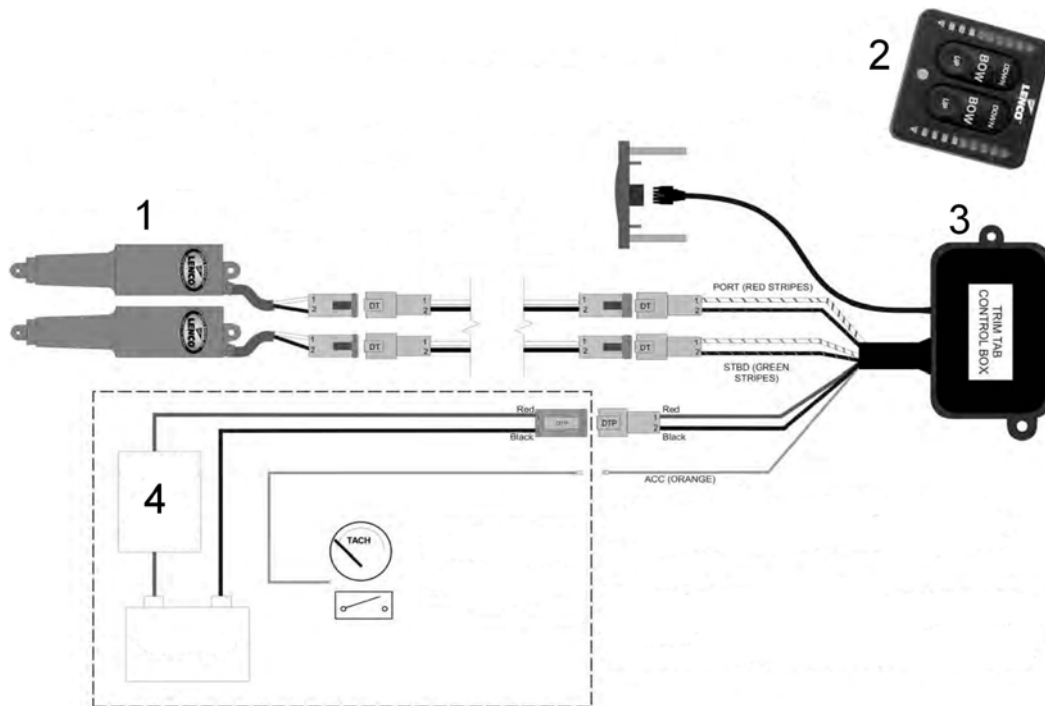

DIAGRAM OF LAYOUT



Reference	Designation
1	Mechanical actuator
2	Control panel
3	Control box
4	Fuse

13.12 PROPELLER SHAFT

- The shaft is stainless steel.
- The shaft is aligned in the factory. When the boat is launched, a check is to be made by a professional.
- A hydrolube ring helps maintain the shaft line in line with the cradle.

This is a wearing ring. Check the hydrolube bush every time the boat is slipped. Change the hydrolube bush if necessary.

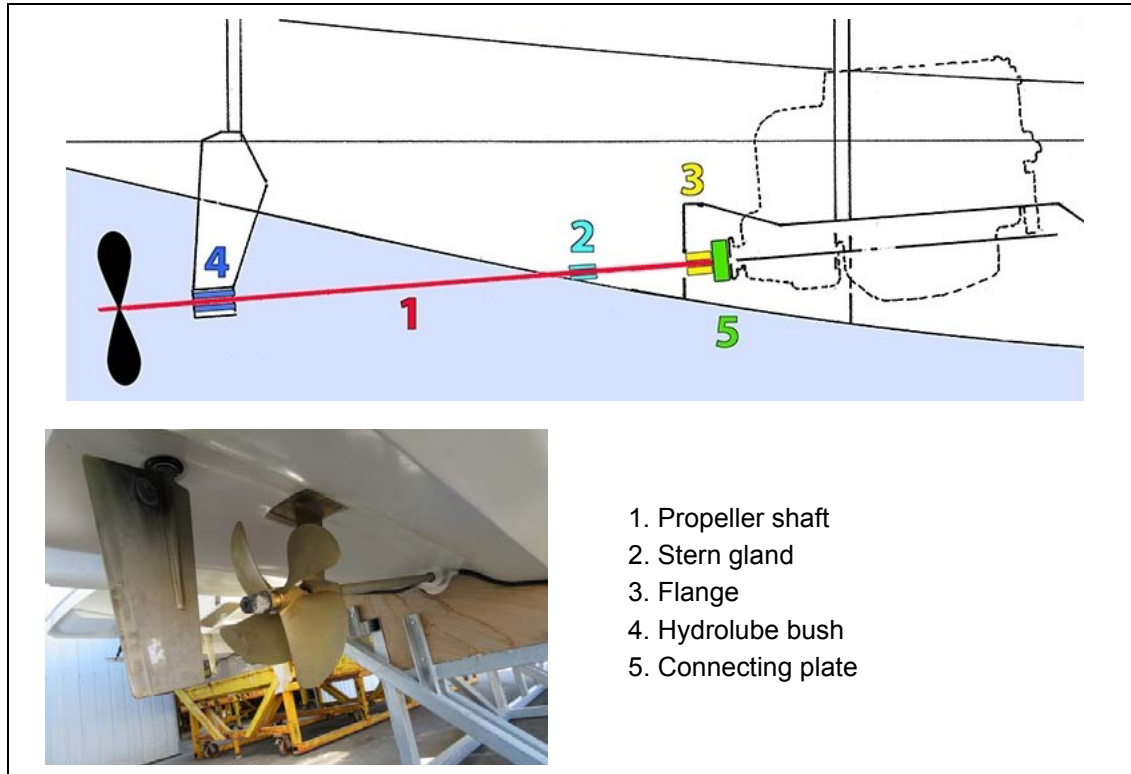

13.13 STERN GLAND

- The stern gland keeps the propeller shaft watertight.
- The stern gland is accessible via the engine compartment.
- Grease the watertight joint every 200 engine hours (or at least once a year). Apply grease as recommended by the mechanic.
- The stern gland is lubricated directly by the engine cooling water.
- After launching the boat, drive the air out from the sleeve by pinching it with your fingers.

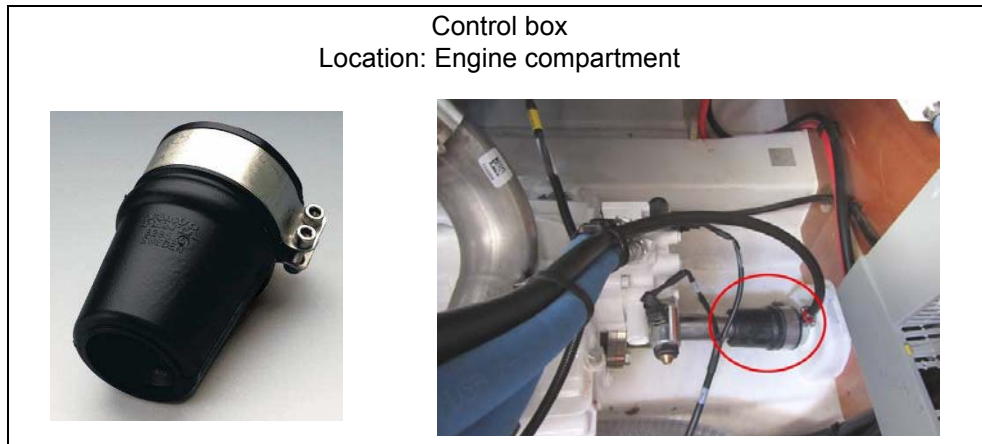

13.14 PROPELLER

- The propeller delivered with the boat is specifically selected after trials carried out in collaboration with the engine manufacturer. Never change the propeller without first consulting a professional engineer.
- Propeller efficiency will drop if the propeller blades are damaged or dirty: clean the blades regularly and attentively.
- During lift-out, check the propeller: it should turn freely on its axis and there should be no play.
- Boats with twin engines are equipped with counter-rotating propellers.



 - Respect speed limits.

STEERING SYSTEM

■ General points	212
■ Diagram of layout	213
■ Hydraulic steering	215
■ Bow thruster & stern thruster	217

14.1 GENERAL POINTS

- The steering is hydraulic.
- The steering system is an important safety feature. For this reason, an annual inspection of the whole system must be carried out by a professional engineer.

Two helm stations are fitted on the boat:

- the main helm station in the saloon,
- the secondary helm station on the flying bridge.

Depending on the version chosen, an additional joystick can be fitted in the cockpit.

NOTE: Some functions or commands are only accessible from the main helm station.

14.2 DIAGRAM OF LAYOUT

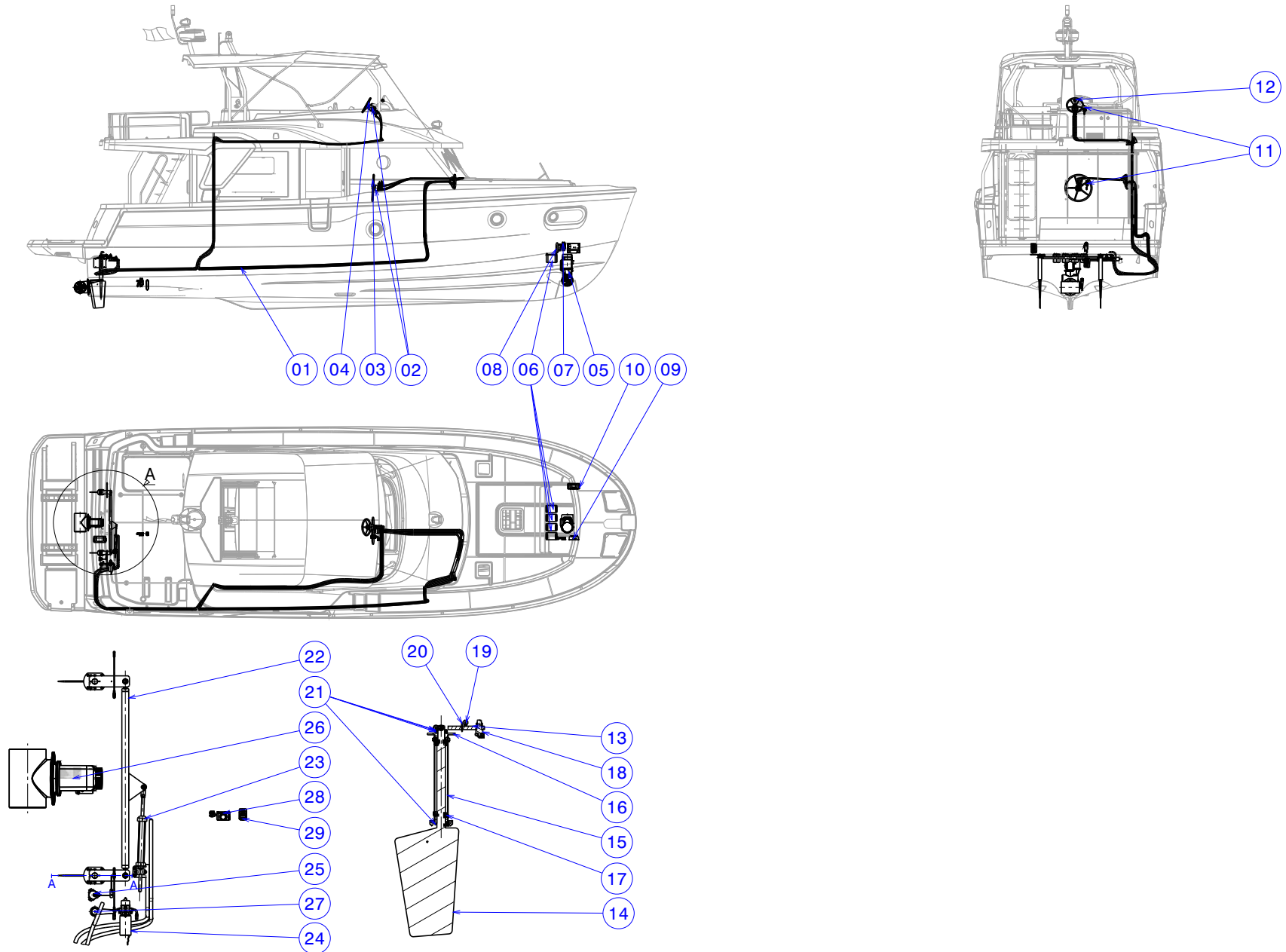

Reference	Designation
1	Hydraulic transmission kit
2	Steering pump
3	Steering wheel
4	Steering wheel
5	Bow thruster
6	Bow thruster batteries
7	Electric battery switch (Bow thruster)
8	Fuse (Bow thruster)
9	Thruster battery charger
10	Bow thruster unit
11	Bow thruster control
12	Tiller angle indicator
13	Stock arm
14	Rudder
15	Rudder tube
16	Flanged bush (High)
17	Flanged bush (Low)
18	Pin
19	Track rod end (Autopilot)
20	Mounting
21	Balance bush
22	Connecting rod
23	Hydraulic piston
24	Hydraulic pump (Autopilot)
25	Helm angle transmitter
26	stern thruster
27	Helm angle sensor
28	Electric battery switch (stern thruster)
29	Fuse (stern thruster)

14.3 HYDRAULIC STEERING

General points

- The hydraulic pump allows the boat's steering to be controlled.
- It is essential that the steering wheel is dismantled using a 'hub puller' type tool. Never tap or lever the steering wheel to access the pump.

Replenishing and bleeding the circuit

- This task must be carried out by a professional engineer: please consult your dealer.
- Use only ISO 22 oil.
- The whole of the hydraulic circuit must be kept scrupulously clean: any impurity may cause deterioration of the steering gear.

After each winter, check

that rotating the wheel to starboard turns the boat to starboard;

that the circuit is properly bled;

that there are no leaks in the connections, pumps, cylinder or flexible hydraulic hoses;

that the pump is filled with oil to the correct level (25 mm of air must be left in the pump : this space is vital for the hydraulic circuit to work properly since it allows the oil to expand);

that the nuts and screws are fully tightened to the correct torque as shown in the manufacturer's instructions;

that the hydraulic hoses have not been flattened or deformed.



Refer to the manufacturer's instructions for use and maintenance.



In the event of an oil leak, consult your dealer.

DIAGRAM OF LAYOUT

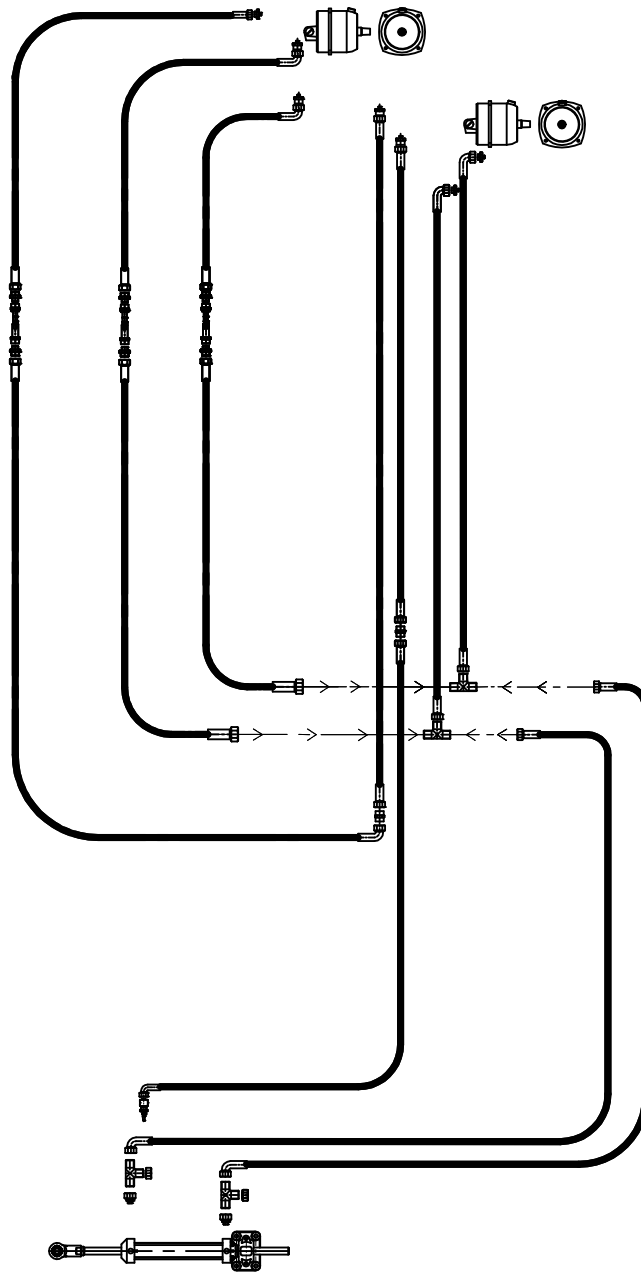

14.4 BOW THRUSTER & STERN THRUSTER

General points

- The thruster motor is DC powered.
- The thruster is a steering aid for manoeuvres at low speed (e.g. picking up a mooring buoy or berthing on a pontoon). The bow thruster must only be used at speeds of less than 2 knots.
- An operating relay is installed in the circuit.
- A fuse protects the electrical circuit.
- The thruster motor has its own battery bank.

Operation

- Before starting the thruster, make sure no swimmers, floating objects or ropes are near the boat.
- Turn on the bow thruster battery switches.
- The engine's positive battery isolator automatically switches on and off when the engine is started/stopped. The thruster circuit negative is connected to the boat's general negative.
- The bow-thruster motor must operate with the boat's engine running.
- A control panel is located in the cockpit / on the flying bridge.
- Press both ON buttons simultaneously to start the thruster.
- Press the OFF button to switch off the thruster.



- Refer to the manufacturer's instructions for use and maintenance.
- Never run the motor when the propeller is out of the water.
- With dual control, be careful to use only one control at a time.
- The motor must not run for longer than 3 minutes (risk of overheating).

Maintenance

- The bow thruster's motor:
 - is lubricated for life and the oil does not require draining;
 - must not be dismantled, even partially;
 - must be coated in antifoul to protect it from marine vegetation.
- Regularly check the charge state of the motor's batteries: a loss of voltage will cause premature wearing of the motor's relay contacts and brushes.

During lift-out

- Check that the propellers turn properly, with neither play nor stiffness.
- Clean the blades carefully.
- Remove the propeller, clean the shaft support and coat the shaft with silicone-based grease before refitting the propeller.
- After cleaning and applying a primer, antifoul the housing and the propellers.
- Change the thruster anode at least once a year (see Chapter: ANODES).



Control

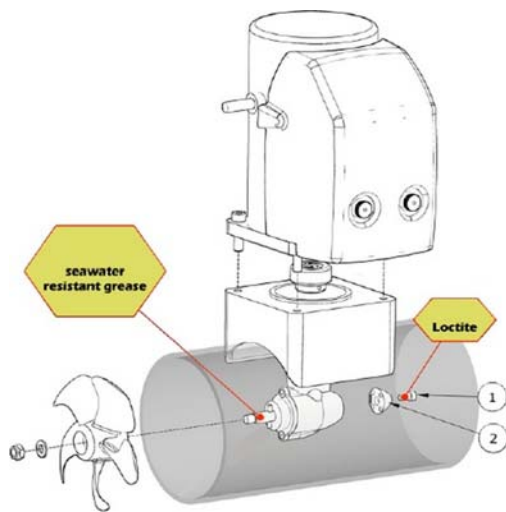

1. Mounting screw
2. Anode

DECK FITTINGS

■ General points	222
■ Equipment.....	224
■ Berthing, anchoring, towing.....	230
■ Main elements of the chain locker.....	232
■ Electric windlass	233

15.1 GENERAL POINTS

Alcohol, solvent or acetone-based solutions must not be used to clean/maintain the outer surfaces of the boat. A warm, soapy, water-based solution is best for this purpose.

15.1.1 GRP

- Regularly brush the deck using a gentle de-greasing agent then rinse the deck with fresh water.
- Use as few cleaning agents as possible.
- Don't use solvents or aggressive detergents.
- Don't dump cleaning agents into the water: Consult the harbourmaster's office to find out the conditions of water use and the maintenance area for cleaning your vessel.
- Do not use a pressure washer.

15.1.2 Plexiglas (PMMA)

- Rinse plexiglas with fresh water.
- Use a polish paste for thin scratches.
- Consult your dealer if deep scratches occur.

15.1.3 Stainless steel

Stainless steel is an alloy of iron and carbon (steel) with the addition of chromium. The chromium creates a protective film which insulates the steel from the surrounding environment. This coating is usually invisible due to its thinness. Thus, despite its name, this steel is not stainless and requires a minimal level of maintenance:

- Chromed tools are preferable whenever handling stainless steel;
- Re-nourish the protective film regularly with passivating paste.



Never use solvents, alcohol, acetone or detergents on plexiglass.



Passivating paste is an acid-based product whose purchase and/or use may be subject to regulation. Please contact your dealer.

15.1.4 Solid wood on exterior wooden panelling

- Wood exposed to harsh conditions such as salty air and UV rays tends to become whiter and to lose its natural colour. This phenomenon has no effect on the intrinsic qualities of the wood, but can spoil its aesthetic appeal.
- To maintain the colour of the wood, regularly wash the woodwork in fresh water using a sponge (if necessary, use a mild soap).
- It is recommended that you oil the external woodwork regularly using teak oil in order to protect it from harsh conditions.

15.1.5 Exterior upholstery

- Bring the removable cushions inside (washed with soapy water then dried) when the vessel is unoccupied.
- Put canvas sheets/protective covering over the fixed upholstery.

Maintenance

To maintain the quality of the fabric, spray regularly with clarified water and brush with a soft brush (such as a clothes brush). A thorough clean every 2 years is recommended.

Stain removal

Follow these steps for routine cleaning:

- Remove as much debris as possible using a soft brush;
- Spray the fabric with water;
- Prepare a cleaning solution using mild soap and water (do not use detergent);
- Wash with a soft brush;
- Wait for the soap solution to act;
- Rinse thoroughly in fresh water;
- Dry in the open air.



Never use detergents, acetone or other harsh products on the wood.



If the wind exceeds 20 knots, it is recommended that you stow all removable protection sheets (Bimini, awnings...).



Never:

- use a heat source (hairdryer/clothes dryer);
- use detergent, silicone, acetone, chlorine-based products or hot water;
- use a high-pressure cleaner.

15.2 EQUIPMENT

15.2.1 Passerelle

Description

- The passerelle allows you to embark/disembark easily when the boat is moored with the stern to the pontoon.
- The gangway is hydraulic and telescopic (adjustable length)/pivoting.
- The passerelle control is located in the cockpit.
- The passerelle is comprised of the external part and a hydraulic unit situated in the engine compartment.
- A control box situated on the hydraulic unit prevents accidental operation of the control panel. As a precaution it is advisable to leave it in the "AUTO" setting.
- The hydraulic pump controlled by the electric motor is situated under the hydraulic unit reservoir. The motor has a speed regulator: it controls the speed at which the passerelle moves.
- The passerelle can also serve as a davit for lifting out the tender.

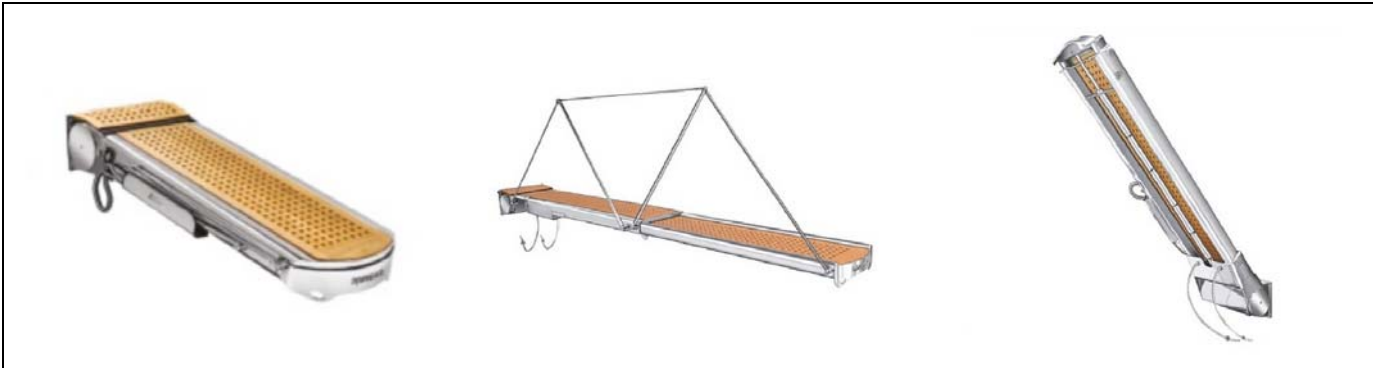

- Do not use the passerelle when at sea.
- Never manoeuvre the passerelle with anyone on it, below it or within its arc of movement.
- Do not use the passerelle as a diving board.



- Refer to the manufacturer's instructions for use and maintenance.
- Maximum load for passerelle: 150kg.
- Telescopic passerelle: Ensure that the stanchions are correctly seated in their sockets before retracting the passerelle.
- Manual operation prevents the position sensors from working: the electronics cannot correct the alignment of the passerelle if it is not retracting correctly into its housing. Use this procedure with caution.
- The gangway can lift a tender or a jet ski weighing up to 170 kg.

Operation

- The passerelle runs on DC power.
- A breaker protects the electrical circuit.
- The passerelle motor is designed to run continuously for a maximum of 4 minutes. After this the motor will cut out automatically (risk of overheating).

Maintenance

- Wash the passerelle regularly with clean water.
- Its location at the stern of the boat makes the passerelle particularly prone to fouling due to the exhaust gases: clean the fouled areas regularly with a non-abrasive detergent.
- Check the oil level in the hydraulic unit once a year.
- Regularly check the connections - these can loosen due to vibration.

Hydraulic unit

Location: Cockpit locker

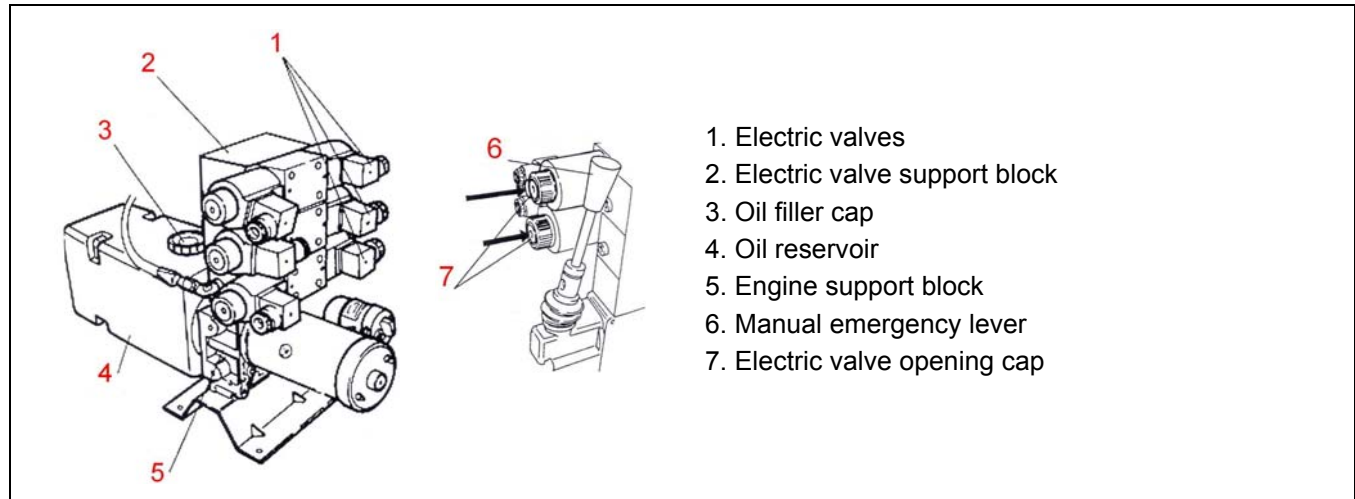

Emergency procedure

In the event of power failure the system can be operated manually. The hydraulic unit is equipped with a manual emergency pump. The electric valve can also be opened or closed manually.

In this case, manoeuvring of the passerelle will be slower but still possible:

1. Activate the lever of the manual pump with one hand. To initiate one of the available hydraulic manoeuvres, open the electric valve of the desired function.
2. With the other hand, press on the electric valve opening cap using a pointed tool (e.g. screwdriver). When the lever is operated, oil will be directed towards the piston. The lever must be activated several times to expel air and pressurise the system.

Control

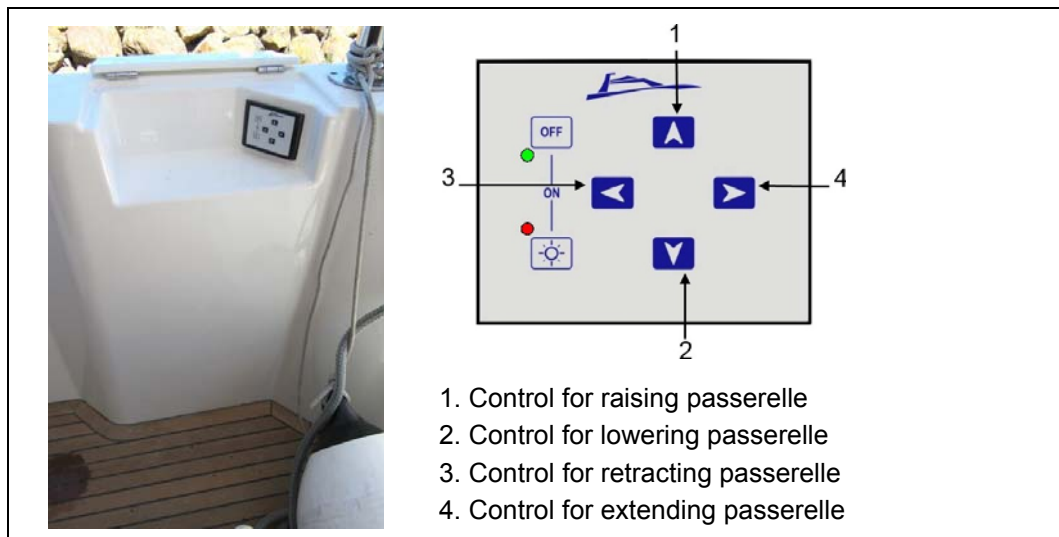

The ON/OFF button turns the control on and off.

The green light is illuminated when the passerelle is being operated.

The red light is illuminated when the system is turned off.

15.2.2 Tender lift

- The platform (tender lift) facilitates launching and recovery of the tender and also serves as a swim platform. Any other use is dangerous and must be strictly avoided.
- The platform runs on the DC power supply.
- A breaker protects the electrical circuit.

LAYOUT OF COMPONENTS

General view



Control
Location: Cockpit



Anodes
Location

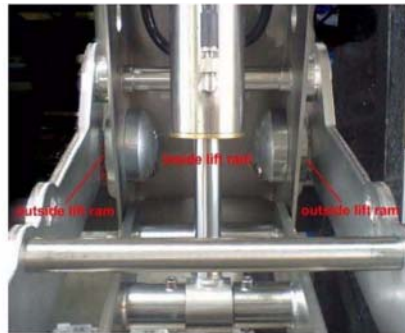
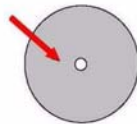
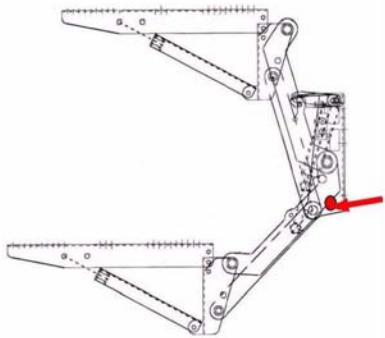

Description:

8 Anodes (4 interior + 4 exterior) 100mm diameter

Manual lever



In case of power failure, push down the valve button to the A or B position and activate the manual pump.

Hydraulic system Location: Cockpit locker



Locking hook Location

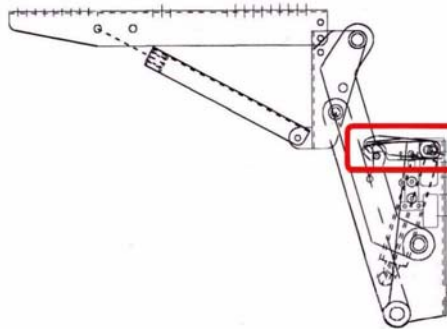

Description

- The hydraulic platform can be lowered below the water level to enable launching/hauling up of light boats (such as attached crafts, jet ski, etc.).
- The platform is controlled from the cockpit.

Operation

- Move the platform up to the LIFTING/LOWERING limit and then press the control for approximately 4 seconds.
NOTE: This time lapse allows the hydraulic fluids to balance out and avoids the risk of desynchronisation of the cylinders and deterioration of the hinge pins.
- The platform motor is designed to operate continuously for a maximum of 4 minutes. Beyond this interval, the motor risks overheating.

Locking

- A safety locking device prevents the platform from moving downwards. Make sure the system is properly locked when sailing or leaving the boat. An alarm is activated when the safety lever is fixed once the platform reaches its highest position. The locking system allows the platform to be lifted when loaded.

Hydraulic system

- The hydraulic pump has a storage reservoir. In case of power failure, the manual level allows the platform to be operated. To manually operate the platform, push the valve button down (using a screwdriver, for example) and activate the manual pump.
- If the platform has been locked for a long time (e.g. during winter storage), the hydraulic pressure of the circuit can be slightly lower.
- The oil level of the pump reservoir must be regularly checked and refilled if needed.



- Climbing onto the platform while it is in operation must be strictly avoided.
- Make sure the lifting/lowering system is unobstructed before operating.
- The hydraulic lifting platform can be used for transportation purposes and for launching and hauling of boats or heavy floating bodies only, within its capacity limits. Any other use is dangerous and must be strictly avoided.
- Maximum load permitted on the platform: 350kg (Load must be uniformly distributed).
- Do not use the platform when under way.
- Make sure that you always sail with the platform in the raised position.
- Do not use the platform in rough seas.
- The boat's engines must be shut down while the platform is operated.



- When you leave the boat, be sure to leave the platform in the raised position.
- Check the platform anodes regularly (see Chapter: ANODES).
- The raised position is the platform's "off" position.
- Use the platform/leave the boat ONLY if the lock is engaged (platform in 'up' position).
- During platform opening or closure:
 - Beware of the system's movements to avoid injuries;
 - Never leave children unattended when they are using the system.



- Wash the platform regularly with clean water.
- The platform's location at the stern of the boat makes it particularly prone to soiling from the exhaust gases: clean the fouled areas regularly with a non-abrasive detergent.
- Check the oil level in the hydraulic unit once a year.

15.3 BERTHING, ANCHORING, TOWING

15.3.1 Anchor points

Responsibility

It is the responsibility of the owner/user of the boat to ensure that the berthing lines, towing cables, chains and mooring lines and the anchors are adequate for the intended use of the boat, i.e. that the lines or chains do not exceed 80 % of the breaking strength of the corresponding anchor point.

	MOORING LINES	MOORING	TOWING
Reference (Diagram on next page)	A	A / B	A / B
Anchor Point Breaking Strength	33,3kN	47,8kN	47,8kN
Mooring Line/Chain Breaking Strength	26,6kN	38,2kN	38,2kN

Be sure to protect the transom platform with a fender to avoid friction with the pontoon.

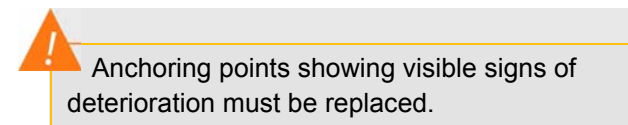

15.3.2 Towing

Responsibility: It is important that the owner thinks through the actions required when securing a towing cable onboard.

Location of attachment points

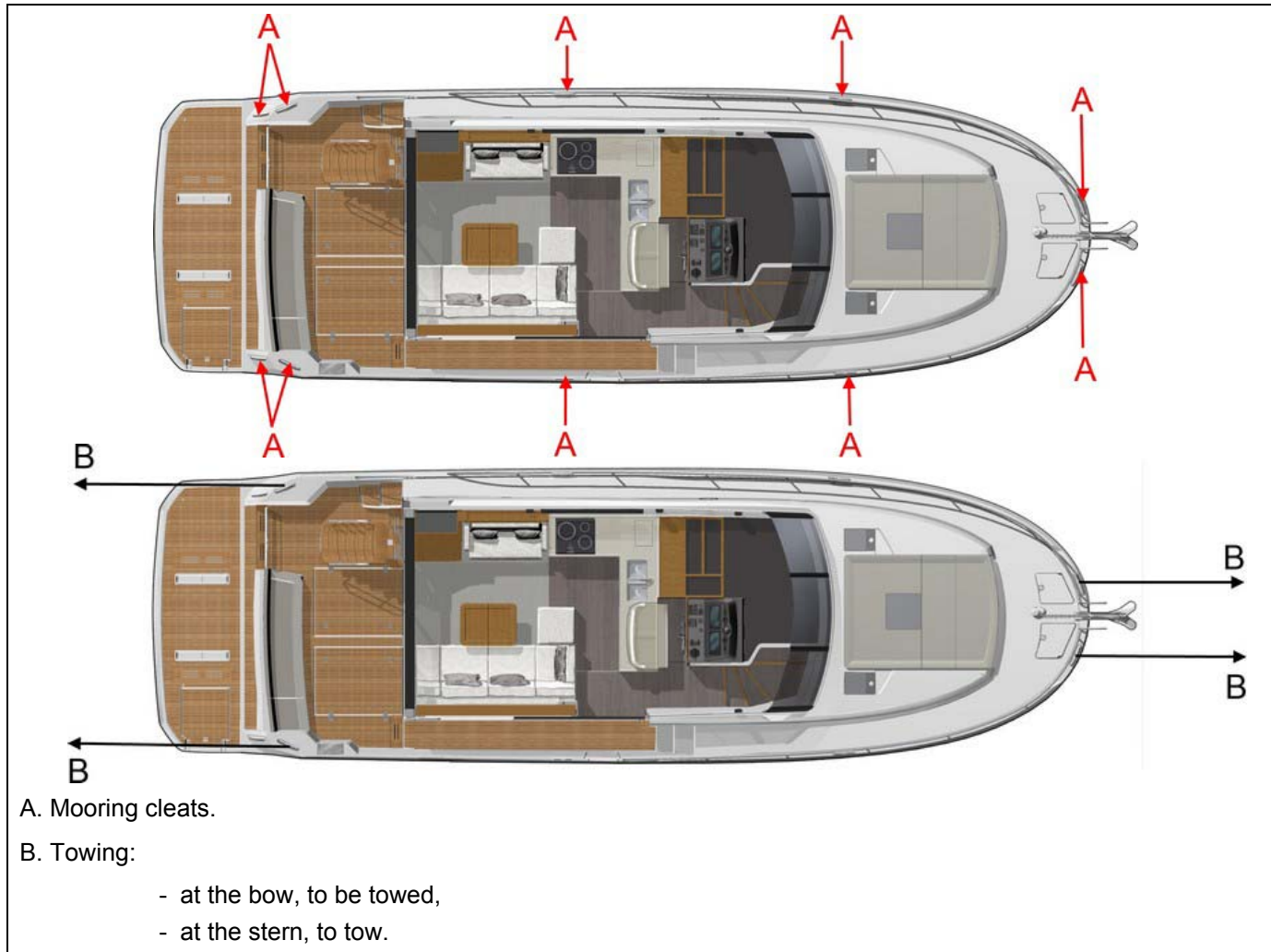

- Generally the breaking strength of lines/ chains must not exceed 80% of the breaking strength of the anchor points.
- Always tow or be towed at low speed. Never exceed the maximum speed of a displacement hull during a tow.
- Be particularly vigilant when the end of a towing cable is being thrown or received (the end may become caught in the propeller).
- A towing cable must always be secured in such a way that it can be released under load.
- Do not try to stop the boat by using a boathook or your foot, hand or any other part of your body.

15.4 MAIN ELEMENTS OF THE CHAIN LOCKER



- ! - Refer to the manufacturer's instructions for use and maintenance.
- Windlass operations are dangerous:
 - Always keep the anchor chain or rope free and unfouled;
 - Carry out manoeuvres carefully and always wear shoes;
 - Avoid wearing baggy clothing and jewellery that could get caught in the engine when it is running. Tie up long hair..

Location: Forward cabin (Under the bed)



Bitter end ring



15.5 ELECTRIC WINDLASS

General points

- The windlass is DC powered.
- The windlass is designed for anchoring purposes: Any other use is dangerous and must be strictly avoided.
- An operation relay is fitted to the electrical circuit.
- A circuit-breaker protects the power supply to the windlass.
- The windlass operation is activated by an operational interlock relay which is powered by the engine's alternator: the windlass only works when the boat's engine is running.
- The controls to raise/lower the windlass are protected by a circuit-breaker positioned between the batteries and the windlass relay.
- Your boat may be equipped with a chain meter: this shows the length of chain let out.

Operation

- Before lowering the anchor, make sure that the chain or anchor rope is securely attached to the bitter end ring.
- Activate the circuit-breaker then use the control to start the windlass.
- The windlass can also be controlled from Ship Control (see Chapter: SHIP CONTROL).

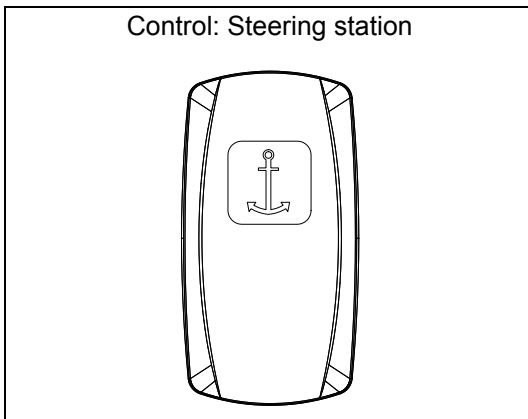

 Refer to the manufacturer's instructions for use and maintenance.

- **When at sea, secure the chain or anchor rope to secure points such as the chain stopper or the anchor rode to the belaying cleat (the windlass must not be used as the only method of securing the chain or rode).**

- With dual control, be careful to use only one control at a time.
- When raising the anchor, use the boat's engine to move towards the position of the anchor until the boat is just over it: never use the windlass as a winch to move the boat forward.
- When out at sea, cut the electrical supply to the windlass.
- Cut the electrical supply when using the windlass manually.

Maintenance

- Once a year, dismantle, carefully wash and grease all the moving parts of the windlass.
- Regularly grease the supply terminals of the electric motor of the windlass and of the relay control box.

Emergency anchoring procedure

In the event of an electrical fault, it is possible to lower the anchor manually: Put the handle in the space provided to release the chain sprocket. Let the chain run out using the handle to control the speed as it runs.



The handle serves only to release the chain sprocket in order to lower the anchor manually should the electric windlass break down.

The handle cannot be used to raise the anchor manually.



- Before anchoring check the depth of water, the power of the current and the nature of the sea bed.

- Check the swing radius once the boat is at anchor.

- After each trip rinse the windlass and anchor chain or rope with fresh water.

HULL FITTINGS

■ Interior upholstery	236
■ Interior woodwork	239
■ Interior maintenance	239

16.1 INTERIOR UPHOLSTERY

GENERAL POINTS

- The interior upholstery is designed for use inside the boat only.
- The fabric used inside the boat has not had any special treatment to protect it from a saline atmosphere or from UV.
- Make sure the curtains are drawn to protect the interior upholstery from exposure to sunlight.

LEATHER

Maintenance

Leather must be regularly cleaned and waxed.

To do so, clean the leather surface with a damp rag. This will remove dust.

Every 6 months to a year depending on use, apply a leather shampoo on the leather then use a hydrating cream which will also protect it.

Stain removal

If the leather surface gets stained, clean immediately using an absorbent piece of paper. Do not scour. Clean with inward motions to prevent the stain from spreading.

- Dab with denatured alcohol, using a piece of cotton to apply (ink and food stains).
- Apply absorbent powder (talcum) on grease stains.

Wait a couple of hours, then brush away the excess powder.

- Other: Apply white vinegar or acetic acid diluted in water.



- Test the product on a small hidden area of the surface before cleaning.
- Avoid excessive moisture.
- Do not scrub on leather surfaces.
- If you notice leather colouring on the rag, immediately stop cleaning.

ALCANTARA (microfibre)

Stain removal

The fabric must be free from dust before stain removal. To do so, use a vacuum cleaner.

Rub with a duster soaked in a solution containing ammonia diluted by 10%. Dilute to the strength appropriate for this fabric. Try it out first on a hidden area such as the hem. If the appearance of the fabric changes, dilute accordingly.

Scrub the Alcantara fabric in all directions, particularly on the stains.

Rinse off the cleaning solution using a damp cloth.

Dry in the open air.

After taking the Alcantara fabric off, it's a good idea to use a gentle brush to bring back its softness.

For difficult stains, dry-cleaning is recommended.

SYNTHETIC FABRIC

Stain removal

If you can remove the fabric:

- Clean in the washing machine (use the programme for delicate fabrics) at 30°.
- Do not iron.
- Never use Javel water.
- Do not dry-clean.
- Do not tumble-dry.

If you cannot remove the fabric:

- Clean with the vacuum cleaner,
- Clean with a foam for synthetic fabrics (see manufacturer's instructions for these products).

COATED FABRIC (PVC)

Maintenance

- The PVC must be regularly cleaned with soapy water to maintain its appearance and to avoid accumulation of debris. We strongly advise against using the following products: lacqueurs, aggressive cleaning products, detergents, xylene or acetone-based products which can cause permanent damage or make the fabric deteriorate. The use of such products is carried out at the owner's risk.

Stain removal

- All stains must be quickly removed to avoid formation of permanent stains.
- Use mild water to remove stains on the surface of the fabric. Use only clean, white, damp pieces of cloth.
- Difficult stains can be removed using a mixture of water (25%) and white spirit.
- Rinse with clean water.
- Dry with a soft piece of cloth.

ACRYLIC (bimini fabric)

Maintenance

To maintain the quality of the fabric, spray regularly with clarified water and brush with a soft brush (such as a clothes brush). A thorough clean every 2 years is recommended.

Stain removal

Follow these steps for routine cleaning:

- Remove as much debris as possible using a soft brush;
- Spray the fabric with water;
- Prepare a cleaning solution using mild soap and water (do not use detergent);
- Wash with a soft brush;
- Wait for the soap solution to act;
- Rinse thoroughly in fresh water;
- Dry in the open air.

16.2 INTERIOR WOODWORK

Varnished wooden panels:

The UV varnish has a matt appearance:

- The acrylic varnish has medium resistance to external chemical damage as well as minor scratches.
- Clean regularly with lukewarm soapy water.
- Do not use polish (this may result in unwanted brightening of appearance).
- For scratches, remove the panel and have it re-varnished by your dealer.

The acrylic varnish used has a matt appearance:

- The acrylic varnish features medium resistance to external chemical damage as well as minor scratches.
- The varnished surface tends to get dirty quickly since it is not flat and reveals hollow pores.
NOTE: Vigorously rubbing a varnish surface gives it a brighter appearance.
- Do not use polish (this may result in unwanted brightening of appearance).
- Gently and regularly clean with lukewarm soapy water.
- For scratches, remove the panel and have it re-varnished by your dealer.

Floors:

- The floors fitted onboard are laminated.
- Clean regularly with lukewarm soapy water.
- In the event of a scratch, remove the plank and replace it with a new one (consult your dealer).

16.3 INTERIOR MAINTENANCE

- Take advantage of fine weather to air the interior upholstery.
- Remove the cushions during lengthy periods of absence.
- Make sure the bilges are clean and dry.
- For lengthy periods of absence, leave the icebox and fridge doors open to prevent mould from developing.
- Use a dehumidifier in the saloon and ensure cabin and storage doors are left open (cupboards, iceboxes...).



- If in doubt or if stains persist, consult a cleaning specialist.
 - For winterisation, ensure the curtains are drawn to prevent prolonged exposure of the varnish and fabric to sunlight. This will prevent the risk of discolouration.
- NEVER:
 - use solvents or abrasive products;
 - use a heat source (hairdryer/clothes dryer);
 - use detergent, silicone, acetone, chlorine-based products or hot water;
 - use a high-pressure cleaner.

HANDLING, TRANSPORT

■ Lifting plan	242
■ Lifting.....	243
■ Upper limit of antifoul	244
■ Launching and lifting	244
■ Winterisation.....	245
■ Transport.....	246

17.1 LIFTING PLAN

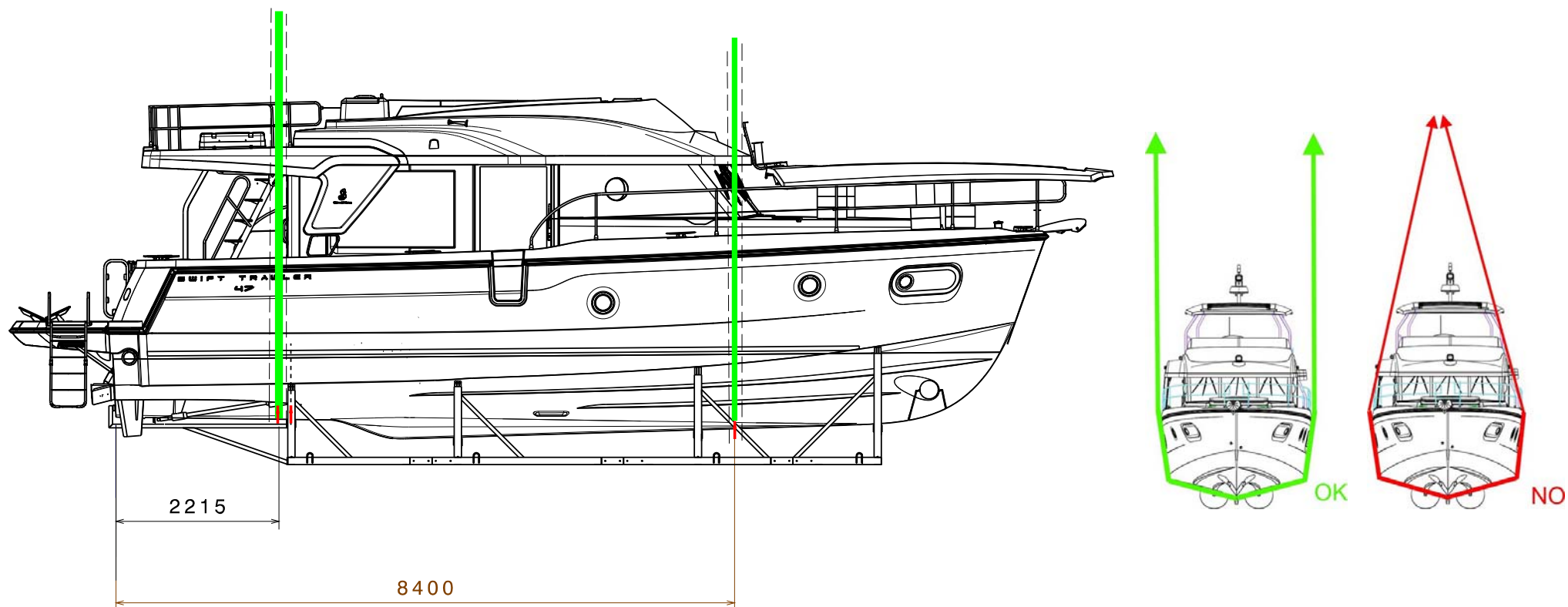

Note: Measurements are expressed in mm.

The position of the lifting slings is shown in the pictogram below:



17.2 LIFTING

- Before the first application of antifouling to the hull, you can lightly sand the hull using wet and dry sandpaper of 400 µm or more.
- The lower hull of your boat should be covered with an anti-fouling paint to prevent the adhesion of marine growth.
- The water quality where your boat is kept, along with the frequency of lifting, will determine the choice of antifouling.
- All bronze or steel surfaces, including the propellers, should be protected by a suitable antifoul paint.
- During lift-out, check the anodes, cutlass bearing and the propeller (see corresponding chapters).
- Antifouling can deteriorate when the boat is ashore or dried out: Please observe the out-of-water time limit set by the supplier.

Before applying antifouling NEVER:

- Do any sandblasting;
- Use any other solvents than ethylic alcohol;
- Use pressure washer detergents;
- Use scrapers;
- Use grinding tools.

If cleaning off existing antifouling requires high pressure washing:

- Ensure the water temperature does not exceed 15 degrees;
- The water pressure must not exceed 150 bar (2175 PSI);
- The distance between the hose nozzle and the hull must not be less than 10 centimetres.

The wet surface area of the boat is approximately: 52m².



- Follow the manufacturer's recommendations closely when applying antifouling.
- Never let antifouling cover:
 - the anodes;
 - the earthing plates (Generator / DC/AC converter);
 - the sensors of the electronic instruments.
- Avoid using copper or tin-based antifouling: these are banned in some countries.

17.3 UPPER LIMIT OF ANTIFOUL

The boat's hull has a shallow indent moulded along its length: the upper marking corresponds to the upper limit of antifoul on the hull.

17.4 LAUNCHING AND LIFTING

The first time you use your boat a high level of skill and attention will be required. The proper functioning of all equipment will depend on the initial set-up being carried out correctly. For this reason the first launch must be carried out under your dealer's supervision.

Before launching

- Replace the speedometer in its housing.
- Check the cleanliness of the seawater filters.
- Check the anodes (see Chapter: ELECTRICAL SYSTEM).
- Check the propeller/hydrolube bush (see Chapter: STEERING SYSTEM).
- Prepare enough fenders and lines.
- Check the engine's seawater intake valve and the fuel feed valve (see Chapter: ENGINE).



Do not stand onboard or beneath the boat during the handling operations.



- When placing the slings make sure that the positioning marks are still visible.
- Immerse the sling fully under the engine mounting.

17.5 WINTERISATION

- Take advantage of laying-up to carry out a full inventory of the equipment.
- Check the expiry dates of the safety equipment.
- Have the liferaft overhauled.
- Empty the complete water system inside and outside and rinse it through with a mix of water and vinegar (do not use chlorine-based products).
- Empty and rinse the entire blackwater system.
- Dry out and clean the boat's bilges.
- Grease and close all the valves and thru-hull fittings.
- Close all the boat's seacocks.
- Remove the depth sounder and speedometer heads.
- Put the covers back on the electronic screens.
- Use a dehumidifier in the saloon and ensure cabin and storage doors are left open.
- Air all of the cushions and upholstery for a while before putting them back onboard and arranging them so as to limit contact between surfaces.
- Close the blackout curtains.
- Leave the fridge/icebox doors open to prevent mould and smells from developing.
- Protect the boat as well as possible with fenders.
- Make sure the boat is properly moored.
- Grease all mechanical and moving parts (bolts, hinges, locks...).
- Remove the movable upholstery.
- Disconnect the batteries. Make sure you recharge them during the Winter period if the boat is left inactive for a long time.



- Engine winterisation requires a professional engineer: please consult your dealer.
- This is not an exhaustive list of recommendations: Your dealer will give you the advice you need and will carry out technical maintenance of your boat.

17.6 TRANSPORT

PACKING PLAN

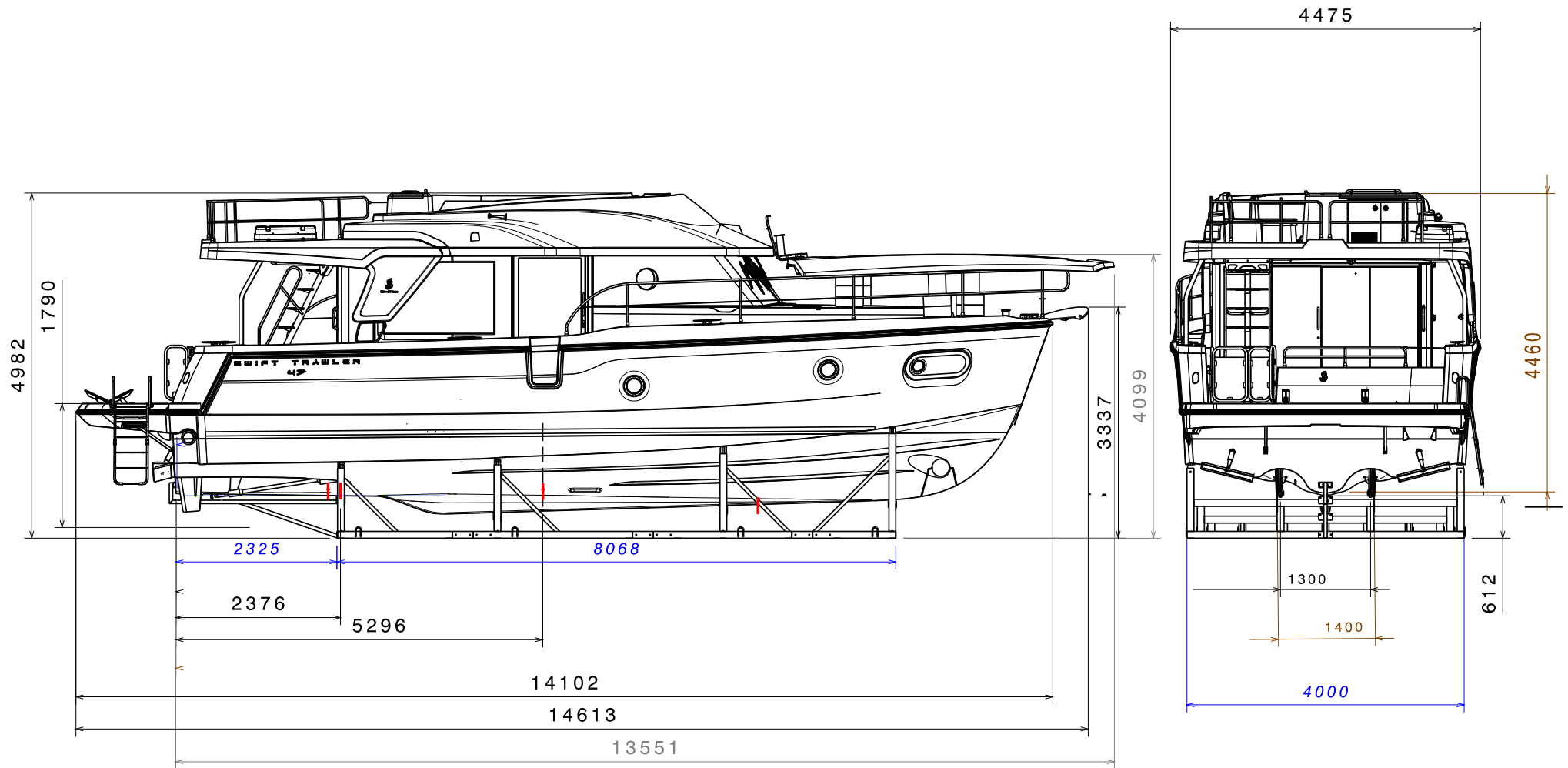

Note: Measurements are expressed in mm.

ENVIRONMENT

18

■ Waste management.....	248
-------------------------	-----

18.1 WASTE MANAGEMENT

- Throw all packaging in the recycling containers provided.
- Once a piece of equipment has stopped working completely, find out about the relevant recycling regulations from your nearest recycling centre or from your dealer.
- Make sure you follow the relevant local laws when scrapping.
- Some onboard equipment can have a toxic effect on the environment and on human health due to the specific substances they contain: Do not throw any equipment in household waste containers and absolutely never dispose of equipment in the sea.
- Dead batteries are toxic to health and to the environment. Batteries must not be put in with household waste and must be recycled separately. Contact the harbour master or a specialist company about recycling them.









- Make sure you know the local environmental regulations and follow the codes of best practice.
 - Do not pump out the toilets or the contents of the black water tank near the coast or in areas where this is forbidden. Use the pump-out facilities available in ports or marinas to empty the contents of the black water tank before leaving port.
 - Make sure you know the international regulations to prevent pollution in the marine environment (MARPOL Convention) and follow these as much as possible.

APPENDIX

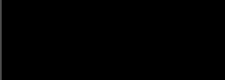
■ Label key	250
-------------------	-----

LABEL KEY

					
Engine group	Plumbing group	Colour - WC group	General electrical equipment	Comfort group	Drainage group



Valve location label

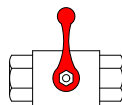



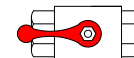





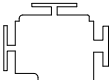











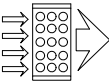





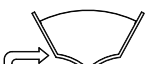





Closed valve

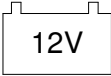

Open valve

Meaning of the symbols

	Motor		Shower		Electric pump
	Port engine		Washbasin		Manual pump
	Starboard engine		Ice maker		WC Toilet
	Propeller shaft		Deck wash		Washer
	Filter		Sea water tap		Dryer
	Hull drainage		Waste water tank		Dishwasher
	Sea water intake		Fresh water tank		Watermaker

	Shore power socket		Fuel tank		Fuel filter
	Service		Holding tank		Inverter
	Generator		Battery stock		Heating
	Breaker		Thruster		Air conditioning

Each label is defined by:

- a functional group (specific colour);
- a component.

